



REDUNDANCY MODULE

- Cost Effective Solution to Build Redundant Systems
- Dual Input with Single Output
- Two Diodes (Common Cathode)
- DC 12-48V $\pm 25\%$ Wide-range Input
- Full Power Between -40°C and $+60^{\circ}\text{C}$
- Width only 32mm
- Rugged Metal Housing
- Quick-connect Spring-clamp Terminals
- Easy Wiring:
Distribution Terminal for Negative Pole Included
- 3 Year Warranty

PRODUCT DESCRIPTION

The YR2.DIODE is a redundancy module, which can be used to build 1+1 and N+1 redundant systems. It is equipped with two input channels, which can be connected to power supplies with up to 10A output current and one output, which can carry nominal currents up to 20A. The module is suitable for power supplies with constant current overload behavior as well as any kind of "Hiccup" overload behavior.

The YR2.DIODE is the perfect solution to use in a redundant system, if the power supply itself is equipped with a DC-OK signal (e.g.: DIMENSION Q-Series). In addition to the YR2.DIODE is the YRM2.DIODE which has a monitoring circuitry included. LEDs and relay contacts signal when one of the two DC-input voltages is not in range due to a non-functioning power supply.

Another interesting application for this diode module is to separate sensitive loads from non-sensitive loads. This avoids the distortion of the power quality for the sensitive loads which can cause controller failures.

Unique quick-connect spring-clamp terminals allow a safe and fast installation and a large international approval package for a variety of applications makes this unit suitable for nearly every situation.

SHORT-FORM DATA

Input voltage	DC 12-48V $\pm 25\%$	
Input voltage range	9-60Vdc	
Input current	2x 0-10A	continuous
	2x 0-16A	for 5 seconds
Output current	0-20A	continuous
	20-32A	for 5 seconds
	25A	at cont. overload/ short circuit
Input to output voltage drop	typ. 0.78V	input: 2x5A
	typ. 0.85V	input: 1x10A
	typ. 0.85V	input: 2x10A
Power losses	typ. 0W	at no load
	typ. 7.8W	input: 2x5A
	typ. 8.5W	input: 1x10A
	typ. 17W	input: 2x10A
Temperature range	-40°C to $+70^{\circ}\text{C}$	operational,
Derating	0.5A/ $^{\circ}\text{C}$	$+60$ to $+70^{\circ}\text{C}$
Dimensions	32x124x102mm	WxHxD

ORDER NUMBERS

Redundancy Module	YR2.DIODE	DC 12-48V
Accessory	ZM1.WALL	Wall/ panel mount bracket
	ZM11.SIDE	Side mount bracket

MAIN APPROVALS

For details and the complete approval list, see chapter 14



UL 508



UL 60950-1



Class I Div 2



ATEX



IECEX





Marine

INDEX

	Page		Page
1. Intended Use	3	16. Physical Dimensions and Weight	15
2. Installation Instructions.....	3	17. Accessories.....	16
3. Input and Output Characteristics	5	17.1. ZM1.WALL - Wall mounting bracket	16
4. Power Losses	6	17.2. ZM11.SIDE - Side mounting bracket	16
5. Lifetime Expectancy and MTBF	7	18. Application Notes.....	17
6. Terminals and Wiring	8	18.1. Recommendations for Redundancy	17
7. Functional Diagram	9	18.2. Inductive and Capacitive Loads	17
8. Front Side and User Elements	9	18.3. Example: 1+1 Redundancy up to 10A.....	17
9. EMC.....	10	18.4. Example: N+1 Redundancy up to 30A	18
10. Environment.....	11	18.5. Example: Battery Back-up	18
11. Protection Features.....	12	18.6. Example: Redundancy for Controls	19
12. Safety Features.....	12	18.7. Example: Decoupling of Branches	20
13. Dielectric Strength.....	12	18.8. Use in a Tightly Sealed Enclosure	20
14. Approved, Fulfilled or Tested Standards	13	18.9. Mounting Orientations.....	21
15. Regulatory Product Compliance.....	14		

The information presented in this document is believed to be accurate and reliable and may change without notice.
 No part of this document may be reproduced or utilized in any form without permission in writing from the publisher.

TERMINOLOGY AND ABBREVIATIONS

PE and  symbol	PE is the abbreviation for Protective Earth and has the same meaning as the symbol  .
Earth, Ground	This document uses the term “earth” which is the same as the U.S. term “ground”.
t.b.d.	To be defined, value or description will follow later.
DC 24V	A figure displayed with the AC or DC before the value represents a nominal voltage with standard tolerances (usually ±15%) included. E.g.: DC 12V describes a 12V battery disregarding whether it is full (13.7V) or flat (10V)
24Vdc	A figure with the unit (Vdc) at the end is a momentary figure without any additional tolerances included.
may	A key word indicating flexibility of choice with no implied preference
shall	A key word indicating a mandatory requirement
should	A key word indicating flexibility of choice with a strongly preferred implementation
1+1 Redundancy	Use of two identical power supplies in parallel to provide continued operation following most failures in a single power supply. The two power supply outputs should be isolated from each other by utilizing diodes or other switching arrangements. E.g. two 10A power supplies are needed to achieve a 10A redundant system.
N+1 Redundancy	Use of three or more identical power supplies in parallel to provide continued operation following most failures in a single power supply. All power supply outputs should be isolated from each other by utilizing diodes or other switching arrangements. E.g.: To achieve a 40A redundant system, five 10A power supplies are needed in a N+1 redundant system.

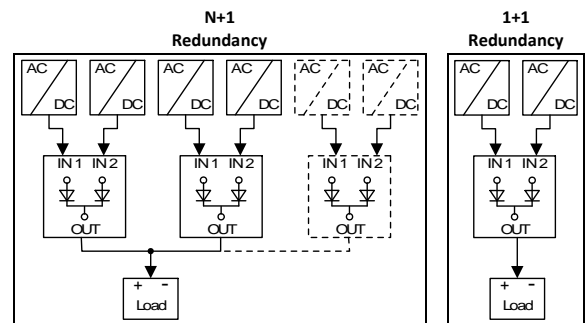

1. INTENDED USE

This device is designed for installation in an enclosure and is intended for commercial use, such as in industrial control, process control, monitoring and measurement equipment or the like. Do not use this device in equipment where malfunction may cause severe personal injury or threaten human life.

The redundancy module can be used with any type of power supply as long as the maximum output current ratings are not exceeded. It is suitable for power supplies with continuous overload current as well as any kind of intermittent (hiccup) overload behavior.

2. INSTALLATION INSTRUCTIONS

WARNING Risk of electrical shock, fire, personal injury or death.

- Turn power off before working on the device and protect against inadvertent re-powering.
- Do not open, modify or repair the device.
- Use caution to prevent any foreign objects from entering into the housing.
- Do not use in wet locations or in areas where moisture or condensation can be expected.
- Do not touch during power-on, and immediately after power-off. Hot surface may cause burns.

Obey the following installation instructions:

This device may only be installed and put into operation by qualified personnel.

This device does not contain serviceable parts. The tripping of an internal fuse is caused by an internal defect.

If damage or malfunction should occur during installation or operation, immediately turn power off and send unit to the factory for inspection.

Install the device in an enclosure providing protection against electrical, mechanical and fire hazards.

Do not ground or earth the positive output pole which could prevent redundancy in case of a ground failure. Ground the negative output pole, when needed.

Use only power supplies with a negligible output ripple voltage in the low frequency range between 50Hz and 10kHz when used in marine applications according to the GL regulations.

Install the device onto a DIN rail according to EN 60715 with the input terminals on the top of the device. Other mounting orientations require a reduction in output current.

Make sure that the wiring is correct by following all local and national codes. Use appropriate copper cables that are designed for a minimum operating temperature of 60°C for ambient temperatures up to +45°C, 75°C for ambient temperatures up to +60°C and 90°C for ambient temperatures up to +70°C. Ensure that all strands of a stranded wire enter the terminal connection.

The device is designed for pollution degree 2 areas in controlled environments. No condensation or frost is allowed.

The enclosure of the device provides a degree of protection of IP20.

The input must be powered from a PELV or SELV source or an "Isolated Secondary Circuit" in order to maintain a SELV or PELV output.

Check correct input polarity. The device will not operate when input voltage is reversed.

The device is designed as "Class of Protection III" equipment according to IEC 61140.

A PE (ground) connection is not required. However, connecting the chassis ground terminal to ground can be beneficial to gain a high EMI immunity.

The device is designed for convection cooling and does not require an external fan. Do not obstruct airflow and do not cover ventilation grid!

The device is designed for altitudes up to 6000m (19685ft). See additional requirements in the product datasheet for use above 2000m (6560ft).

Keep the following minimum installation clearances: 40mm on top, 20mm on the bottom, 5mm left and right side. Increase the 5mm to 15mm in case the adjacent device is a heat source. When the device is permanently loaded with less than 50%, the 5mm can be reduced to zero.

The maximum surrounding air temperature is +70°C (+158°F). The operational temperature is the same as the ambient or surrounding air temperature and is defined 2cm below the device.

The device is designed to operate in areas between 5% and 95% relative humidity.

Installation Instructions for Hazardous Location Areas

The device is suitable for use in Class I Division 2 Groups A, B, C, D locations and for use in Group II Category 3 (Zone 2) environments.

Hazardous Location classification: ATEX: EPS 11 ATEX 1 312 X, II 3G Ex ec IIC T4 Gc

WARNING EXPLOSION HAZARDS!

Substitution of components may impair suitability for this environment. Do not disconnect the device unless power has been switched off or the area is known to be non-hazardous.

A suitable enclosure must be provided for the end product which has a minimum protection of IP54 and fulfils the requirements of the EN 60079-0.

3. INPUT AND OUTPUT CHARACTERISTICS

Number of inputs		2	
Number of outputs		1	
Input voltage	nom.	DC 12-48V $\pm 25\%$	The input circuitry must meet the SELV requirements stipulated by IEC/EN/UL 60950-1.
Input voltage range		9-60Vdc	
Voltage drop, input to output	typ.	0.78V	at 2x5A, see Fig. 3-1
	typ.	0.85V	at 1x10A, see Fig. 3-2
	typ.	0.85V	at 2x10A, see Fig. 3-1
Input current	nom.	2x 0-10A	continuous
	nom.	1x 0-20A	continuous, see note 1
	nom.	2x 10-16A	for 5 seconds
Peak input current	max.	150A	for maximal 10ms per input
Output current	nom.	20A	continuous
	nom.	20-32A	for 5 seconds
	max.	25A	at continuous overload or short circuit, see note 2
Reverse current	max.	2mA	per input, -40°C to +60°C
Reverse voltage	max.	200Vdc	voltage applied to the output, continuously allowed

Note 1: Each input can be loaded up to 20A. At currents above 10A, the other input should not be loaded. It is preferable to parallel the two inputs in order to minimize the power loss in such cases.

Note 2: Ensure that the continuous output current does not exceed 25A. Check the short-circuit current of the power sources and if the power source can deliver more than 25A together, use an appropriate fuse on the output.

Fig. 3-1 Input to output voltage drop when both inputs draw current
(typical 1+1 redundant case, when the output voltages of the two units are equal or set into "parallel use" mode)

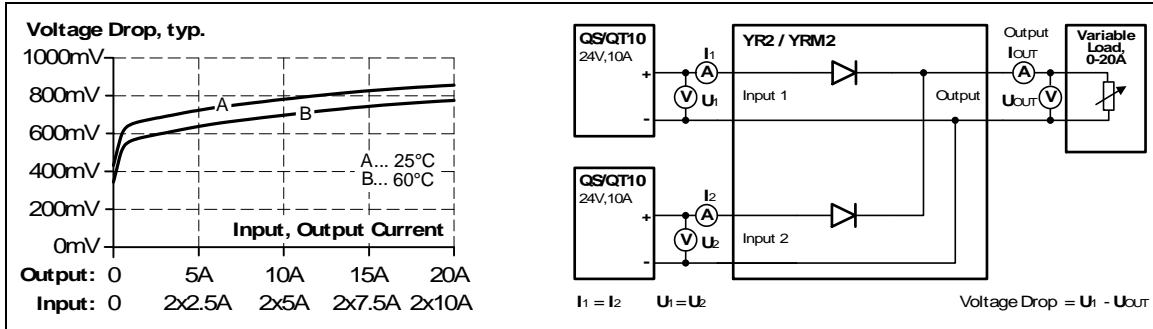
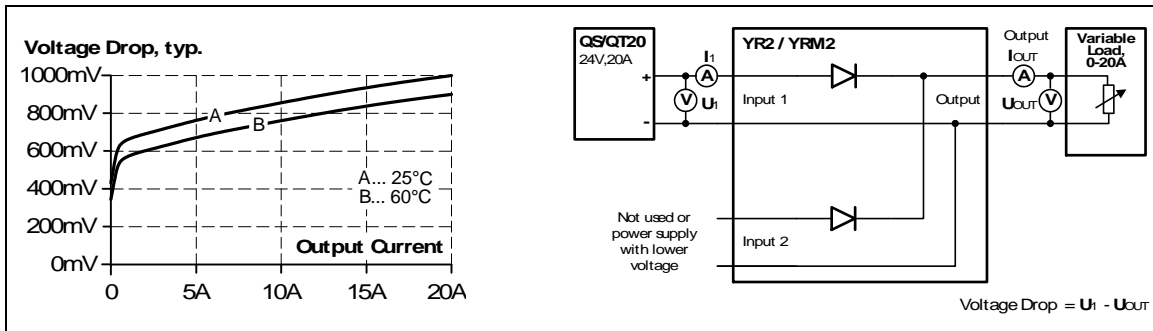

Fig. 3-2 Input to output voltage drop when only one input draws current



4. POWER LOSSES

DC 24V			
Power losses	typ.	7.8W	input: 2x5A
	typ.	8.5W	input: 1x10A
	typ.	17.0W	input: 2x10A
Standby power losses	typ.	0W	at no output current

Fig. 4-1 Power losses

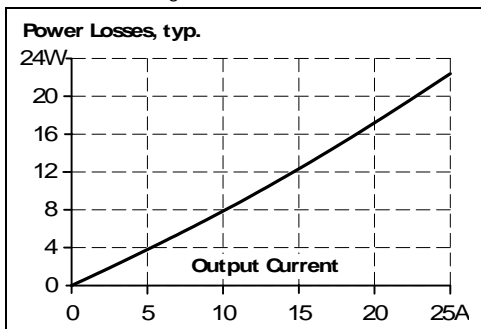

5. LIFETIME EXPECTANCY AND MTBF

The redundancy module has two input channels which are completely independent from each other. Each control circuit, auxiliary voltage source, or other circuitry in the module are designed separately for each input. The dual input redundancy module can be considered as two single redundancy modules combined together in one housing. The only common point is the circuit trace that ties the two separate circuits together at the output.

The MTBF figures below are for the entire dual input module. If the MTBF number of only one path is needed, simply double the value from the table.

The redundancy module does not have electrolytic capacitors included. Therefore, the lifetime expectancy is extremely high.

Input / output current conditions		Input: 2x10A Output: 20A	Input: 2x5A Output: 10A	
Lifetime expectancy *)	min.	25 years	25 years	at 24V and 40°C
	min.	25 years	25 years	at 24V and 25°C
MTBF **) SN 29500, IEC 61709		46 500 000h	55 700 000h	at 24V 40°C
		70 000 000h	84 000 000h	at 24V 25°C
MTBF **) MIL HDBK 217F		36 200 000h	43 500 000h	at 24V and 40°C (Ground Benign GB40)
		41 100 000h	49 300 000h	at 24V and 25°C (Ground Benign GB25)

*) The **Lifetime expectancy** shown in the table indicates the minimum operating hours (service life).

) **MTBF stands for **Mean Time Between Failure**, which is calculated according to statistical device failures, and indicates reliability of a device. It is the statistical representation of the likelihood of a unit to fail and does not necessarily represent the life of a product.

The MTBF figure is a statistical representation of the likelihood of a device to fail. A MTBF figure of e.g. 1 000 000h means that statistically one unit will fail every 100 hours if 10 000 units are installed in the field. However, it can not be determined if the failed unit has been running for 50 000h or only for 100h.

6. TERMINALS AND WIRING

	Input and output
Type	Bi-stable, quick-connect spring clamp terminals. IP20 Finger safe construction. Suitable for field- and factory installation. Shipped in open position.
Solid wire	0.5-6mm ²
Stranded wire	0.5-4mm ²
American Wire Gauge	20-10 AWG
Max. wire diameter	2.8mm (including ferrule)
Wire stripping length	10mm / 0.4inch
Pull-out force	10AWG:80N, 12AWG:60N, 14AWG:50N, 16AWG:40N (according to UL486E)

Instructions:

- a) Use appropriate copper cables that are designed for minimum operating temperatures of:
60°C for ambient up to 45°C and
75°C for ambient up to 60°C and
90°C for ambient up to 70°C minimum.
- b) Follow national installation codes and installation regulations!
- c) Ensure that all strands of a stranded wire enter the terminal connection!
- d) Ferrules are allowed.
- e) Do not connect or disconnect the wires from the terminals below -25°C (-13°F).

Fig. 6-1 Connecting a wire

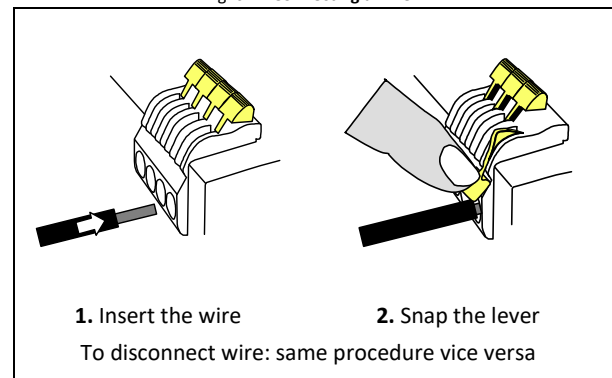

7. FUNCTIONAL DIAGRAM

Fig. 7-1 Functional diagram

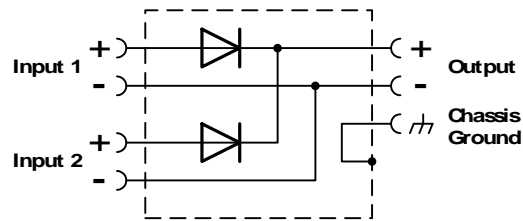

8. FRONT SIDE AND USER ELEMENTS

Fig. 8-1 Front side



A Output terminals

B Chassis ground terminal

Connection of the chassis to ground is optional and not required since the unit fulfils the requirements according to protection class III.

C Input terminals for input 1

D Input terminals for input 2

9. EMC

The redundancy module is suitable for applications in industrial environment as well as in residential, commercial and light industry environment without any restrictions. A detailed EMC report is available on request.

EMC Immunity	According generic standards: EN 61000-6-1 and EN 61000-6-2			
Electrostatic discharge	EN 61000-4-2	Contact discharge	8kV	Criterion A
		Air discharge	15kV	Criterion A
Electromagnetic RF field	EN 61000-4-3	80MHz-2.7GHz	10V/m	Criterion A
Fast transients (Burst)	EN 61000-4-4	Input lines	2kV	Criterion A
		Output lines	2kV	Criterion A
Surge voltage on input lines	EN 61000-4-5	+/- → Chassis ground	1kV	Criterion A
Surge voltage on output lines	EN 61000-4-5	+/- → Chassis ground	1kV	Criterion A
Conducted disturbance	EN 61000-4-6	0.15-80MHz	10V	Criterion A
Power-frequency magnetic field *)	EN 61000-4-8	50Hz	30A/m	Criterion A

Criteria:

A: Redundancy module shows normal operation behavior within the defined limits.

Notes:

*) A test is not applicable according to EN 61000-6-2, since the device does not contain components susceptible to magnetic fields, e.g. hall elements, electrodynamic microphones, etc.

EMC Emission	According generic standards: EN 61000-6-3 and EN 61000-6-4	
Conducted emission	IEC/CISPR 16-1-2, IEC/CISPR 16-2-1	Class B, input lines *)
	IEC/CISPR 16-1-2, IEC/CISPR 16-2-1	Class B, output lines *)
Radiated emission	EN 55011, EN 55032	Class B

This device complies with FCC Part 15 rules.

Operation is subjected to following two conditions: (1) this device may not cause harmful interference, and (2) this device must accept any interference received, including interference that may cause undesired operation.

*) Provided, that power sources connected on the inputs fulfill the class B requirements too.

10. ENVIRONMENT

Operational temperature *)	-40°C to +70°C (-40°F to 158°F)	Reduce output power above +60°C
Output derating	0.5A/°C	60-70°C (140°F to 158°F), see
Storage temperature	-40 to +85°C (-40°F to 185°F)	for storage and transportation
Humidity **)	5 to 95% r.H.	IEC 60068-2-30
Vibration sinusoidal ***)	2-17.8Hz: ±1.6mm 17.8-500Hz: g 2 hours / axis	IEC 60068-2-6
Shock ***)	30g 6ms, 20g 11ms 3 bumps / direction 18 bumps in total	IEC 60068-2-27
Altitude	0 to 2000m (0 to 6 560ft) 2000 to 5000m (6 560 to 16 400ft)	without any restrictions reduce output power or ambient temperature, see Fig. 10-2
Altitude derating	1.25A/1000m or 5°C/1000m	> 2000m (6500ft), see Fig. 10-2
Over-voltage category	not applicable	The concept of the overvoltage category is used for equipment energized directly from the low voltage mains (IEC 60664-1 §4.3.3.2.1).
Degree of pollution	2	IEC 62103, EN 50178, not conductive

*) Operational temperature is the same as the ambient temperature and is defined as the air temperature 2cm below the unit.

**) Do not energize while condensation is present

***) Tested in combination with DIN rails according to EN 60715 with a height of 15mm and a thickness of 1.3mm and standard mounting orientation.

Fig. 10-1 Output current vs. ambient temp.

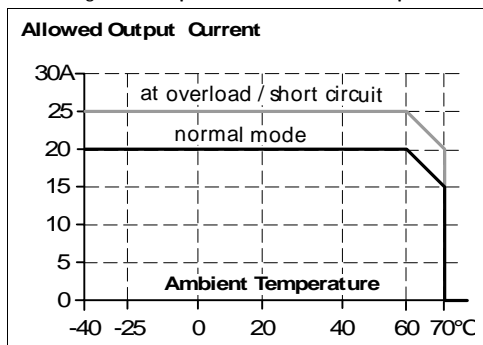
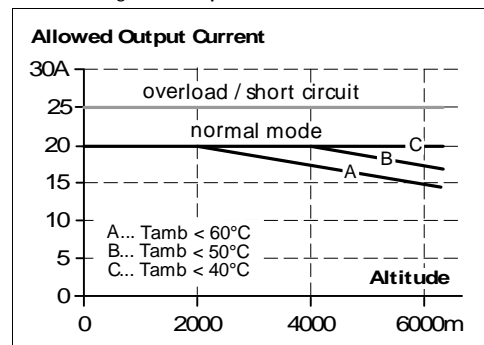

Fig. 10-2 Output current vs. altitude



11. PROTECTION FEATURES

Output over-current protection	not included	
Reverse input polarity protection	included	unit does not start when input voltage is reversed
Degree of protection	IP 20	EN/IEC 60529
Penetration protection	> 3.6mm	e.g. screws, small parts
Over-temperature protection	not included	
Input transient protection	not included	
Output transient protection	included	see EMC chapter
Internal input fuse	not included	

12. SAFETY FEATURES

Input / output separation	no galvanic separation	200V epitaxial diode between input and output
Safety level of output voltage	The output voltage is regarded to be SELV (EN 60950-1) or PELV (EN 60204-1, EN 50178, IEC 60364-4-41) if the input voltage fulfil the requirements for a SELV source or PELV source.	
Class of protection	III	PE (Protective Earth) or chassis connection not required
PE resistance	< 0.10hm	between housing and chassis-ground terminal

13. DIELECTRIC STRENGTH

The input and output voltages have the same reference, are floating and have no ohmic connection to ground. Type and factory tests are conducted by the manufacturer. Field tests may be conducted in the field using the appropriate test equipment which applies the voltage with a slow ramp (2s up and 2s down). Connect input/output terminals together before conducting the test.

When testing, set the cut-off current settings to the value in the table below.

Fig. 13-1 Dielectric strength

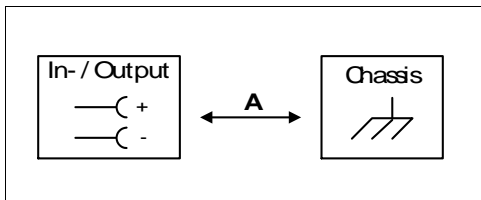

	A	
Type test	60s	500Vac
Factory test	5s	500Vac
Field test	5s	500Vac
Cut-off current setting	> 2mA	

14. APPROVED, FULFILLED OR TESTED STANDARDS

UL 508



UL Certificate
Listed equipment for category NMTR - Industrial Control Equipment
Applicable for US and Canada
E-File: E198865

IEC 60950-1



CB Scheme Certificate
General safety requirements for Information Technology Equipment (ITE)

UL 60950-1



UL Certificate
Recognized component for category QQQQ - Information Technology Equipment (ITE)
Applicable for US and Canada
E-File: E137006

ATEX



Agency Certificate (Bureau Veritas)
EN 60079-0 Explosive atmospheres - General requirements
EN 60079-7 Equipment protection by type of protection "e" Certificate: EPS 11 ATEX 1 312 X
Temperature Code: T4
Type of Protection: ec nC

IECEX



IECEX Certificate
IEC 60079-0 Explosive atmospheres - General requirements
IEC 60079-7 Equipment protection by type of protection "e" Certificate: IECEX EPS 12.0032 X
Temperature Code: T4
Type of Protection: ec

Class I Div 2



CSA Certificate
Power Supplies for Hazardous Location
Applicable for Canada and US
CSA Class: 5318-01 (Canada), 5318-81 (USA)
Temperature Code: T4
Groups: A, B, C and D

Marine (DNV)



DNV Certificate
DNV Type approved product
Certificate: TAA00001JT
Temperature: Class D
Humidity: Class B
Vibration: Class C
EMC: Class A
Enclosure: Class A

Marine (ABS)



ABS Design Assessment Certificate
ABS (American Bureau of Shipment) assessed product
Certificate: 17-HG1599236-PD

IEC 60068-2-60



Manufacturer's Declaration (Online Document)
Environmental Tests, Flowing Mixed Gas Corrosion Test
Test Ke - Method 4
H2S: 10ppb
NO2: 200ppb
Cl2: 10ppb
SO2: 200ppb
Test Duration: 3 weeks, which simulates a service life of 10 years.

ISA-71.04 G3

Corrosion
G3-ISA-71.04 ✓

Manufacturer's Declaration (Online Document)
Airborne Contaminants Corrosion Test
Severity Level: G3 Harsh
H2S: 100ppb
NOx: 1250ppb
Cl2: 20ppb
SO2: 300ppb
Test Duration: 3 weeks, which simulates a service life of 10 years

VDMA 24364

LABS
VDMA 24364-C1-LW

Paint Wetting Impairment Substances Test (or LABS-Test)
Tested for Zone 2 and test class C1 according to VDMA 24364-C1-L/W for solvents and water-based paints

15. REGULATORY PRODUCT COMPLIANCE

EU Declaration of Conformity



The CE mark indicates conformance with the
- EMC directive
- ATEX directive
- RoHS directive

REACH Regulation (EU)



Manufacturer's Declaration
EU regulation regarding the Registration, Evaluation, Authorisation and Restriction of Chemicals (REACH) fulfilled.
EU Regulation (EC) 1907/2006.

WEEE Regulation



Manufacturer's Declaration
EU Regulation on Waste Electrical and Electronic Equipment
Registered as business to business (B2B) products.
EU Regulation 2012/19/EU

UKCA



UKCA Declaration of Conformity
Trade conformity assessment for England, Scotland and Wales
The UKCA mark indicates conformity with the UK Statutory Instruments
2016 No.1101,
2016 No.1091,
2012 No.3032

CCC



CCC Certificate
China Compulsory Certification (CNCA-C23-01:2019)
Certificate for devices made in Suzhou/China (PULS Electronics):
2021122303114443
Certificate for devices made in Chomutov/Czech Republic (PULS investiční): 2021122303114444
CCC-Ex

16. PHYSICAL DIMENSIONS AND WEIGHT

Weight	290g / 0.64lb
DIN rail	Use 35mm DIN rails according to EN 60715 or EN 50022 with a height of 7.5 or 15mm. The DIN rail depth must be added to the unit depth (102mm) to calculate the total required installation depth.
Installation clearances	See chapter 2

Fig. 16-1 Front view

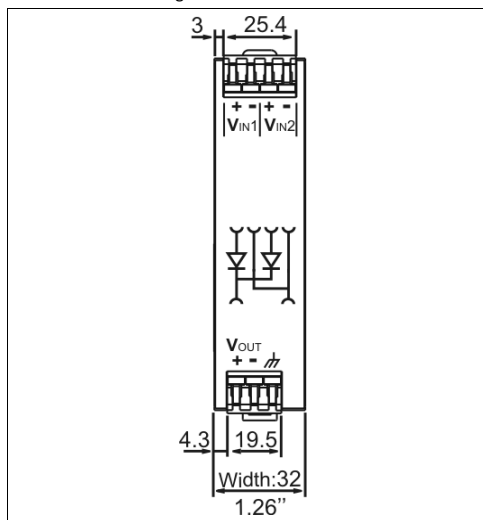
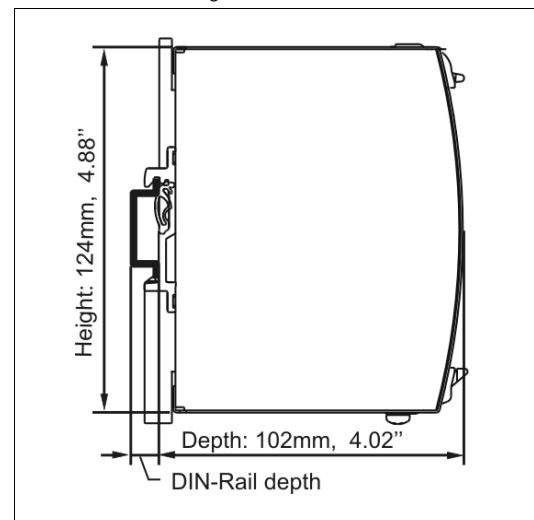

Fig. 16-2 Side view



17. ACCESSORIES

17.1. ZM1.WALL - WALL MOUNTING BRACKET

This standard bracket is used to mount the YR40 redundancy module onto a flat surface without utilizing a DIN rail.

Fig. 17-1 ZM1.WALL Wall mounting bracket

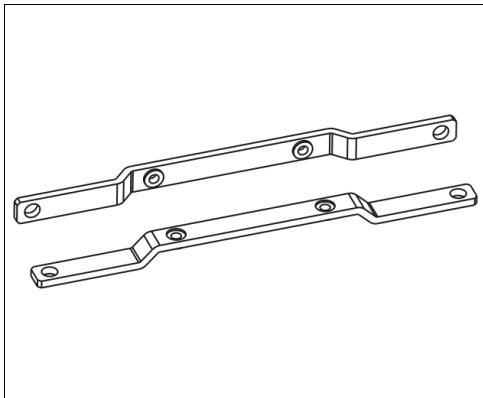
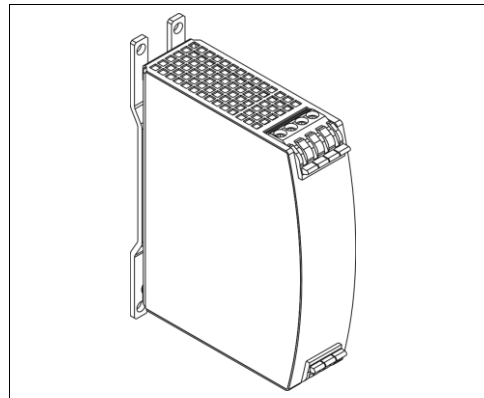

Fig. 17-2 Assembled wall mounting bracket



17.2. ZM11.SIDE - SIDE MOUNTING BRACKET

This bracket is used to mount the YR80 redundancy module sideways with or without utilizing a DIN rail.

The two aluminum brackets and the black plastic slider of the unit have to be detached, so that the steel brackets can be mounted.

For sideways DIN rail mounting, the removed aluminum brackets and the black plastic slider need to be mounted on the steel bracket.

Fig. 17-3
ZM11.SIDE Side mounting bracket

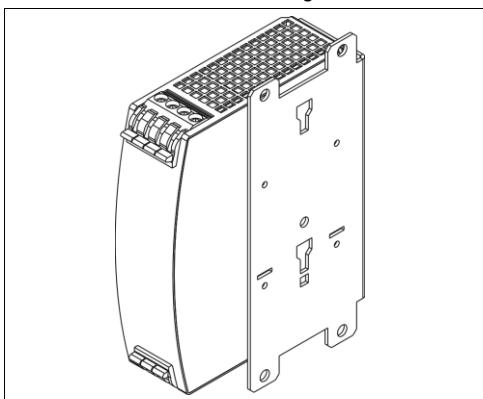
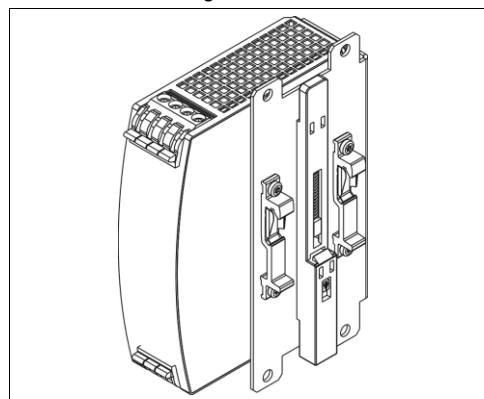

Fig. 17-4
Side mounting with DIN rail brackets



18. APPLICATION NOTES

18.1. RECOMMENDATIONS FOR REDUNDANCY

Recommendations for the configuration of redundant power systems:

- Use separate input fuses for each power supply.
- Use three-phase power supplies to gain functional safety if one phase fails.
- When single-phase power supplies are utilized connect them to different phases or mains circuits if possible.
- Set the power supply in "Parallel-Use" mode if this feature is available
- It is desirable to set the output voltages of all power supplies to the same value.

18.2. INDUCTIVE AND CAPACITIVE LOADS

The unit is designed to supply any kind of loads, including unlimited capacitive and inductive loads.

18.3. EXAMPLE: 1+1 REDUNDANCY UP TO 10A

1+1 Redundancy up to 10A requires two 10A power supplies and one YR2.DIODE redundancy module.

Fig. 18-1 Wiring diagram, 1+1 Redundancy, 10A output current

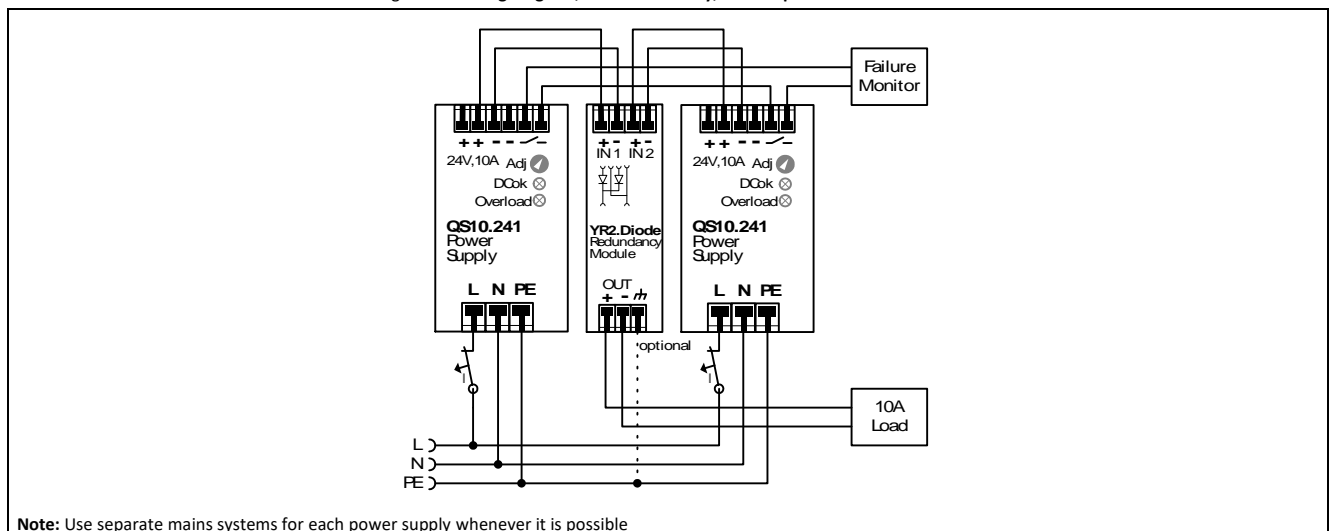

18.4. EXAMPLE: N+1 REDUNDANCY UP TO 30A

N+1 Redundancy up to 30A requires four 10A power supplies and two YR2.DIODE redundancy modules.

Fig. 18-2 Wiring diagram, n+1 Redundancy, 30A output current

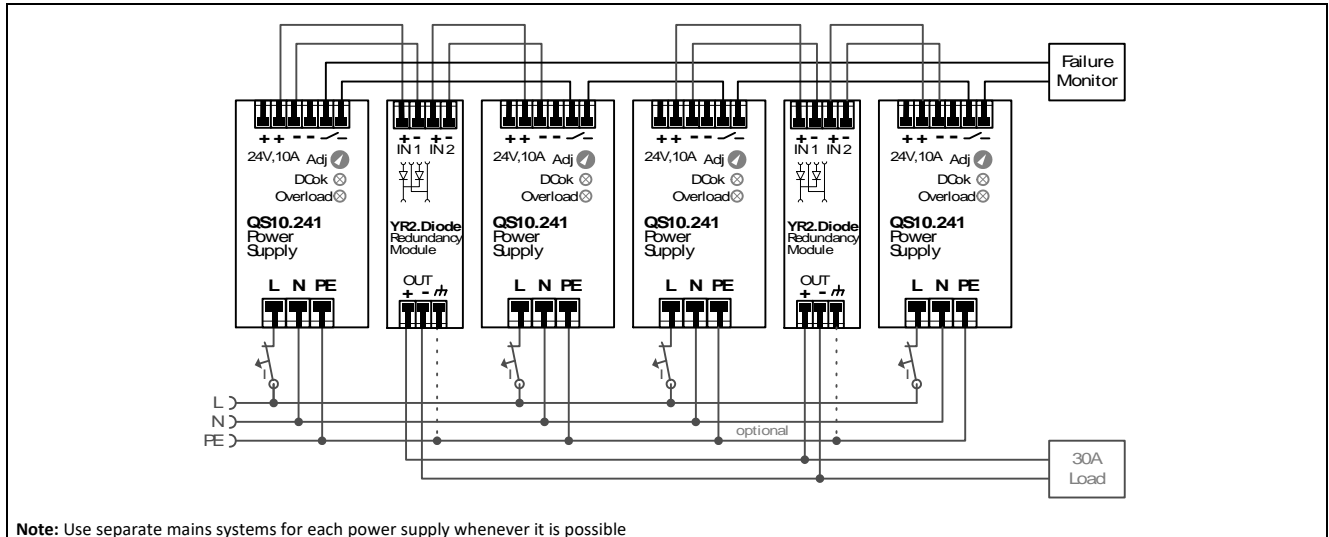

18.5. EXAMPLE: BATTERY BACK-UP

A battery back-up with 10A requires one 10A power supply and one YR2.DIODE redundancy module.

Please note:

Set output voltage of power supply to 26.5Vdc minimum to ensure, that the load current is delivered from the power supply and not from charger (battery). Use a fuse between battery and YR2.DIODE!

Fig. 18-3 Wiring diagram, 10A Battery back-up

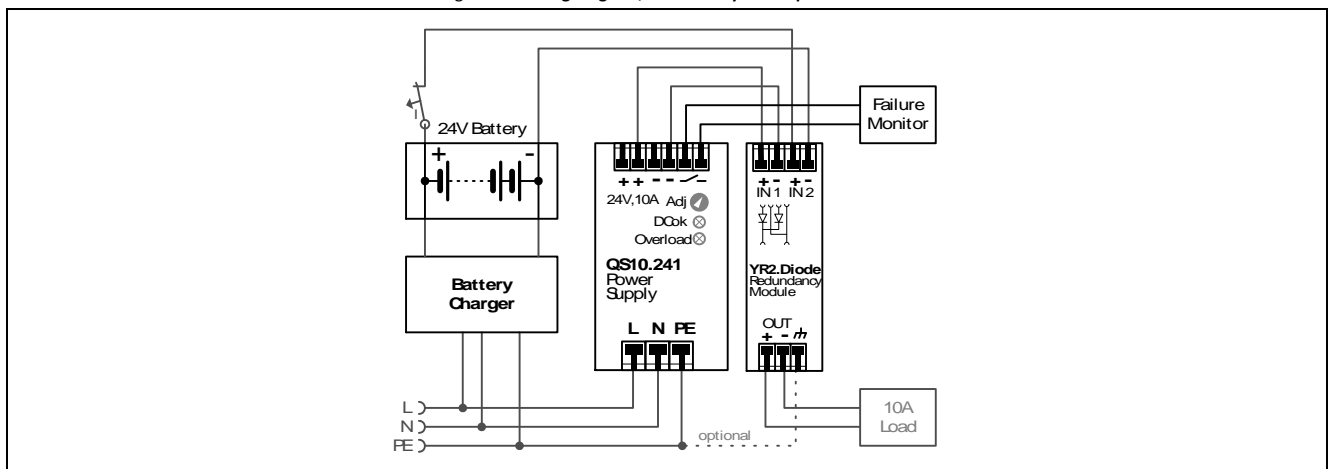

18.6. EXAMPLE: REDUNDANCY FOR CONTROLS

The example shows a cost effective solution to get redundant power for a PLC or controller system.

In many cases, two power supplies are used; one for the demanding loads and another one for the controls and sensitive loads. The power supply for the demanding loads can be used as a redundant source to supply the controls.

Traditional approach:

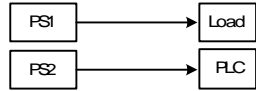

Improved approach:

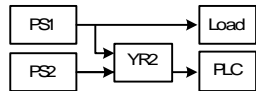
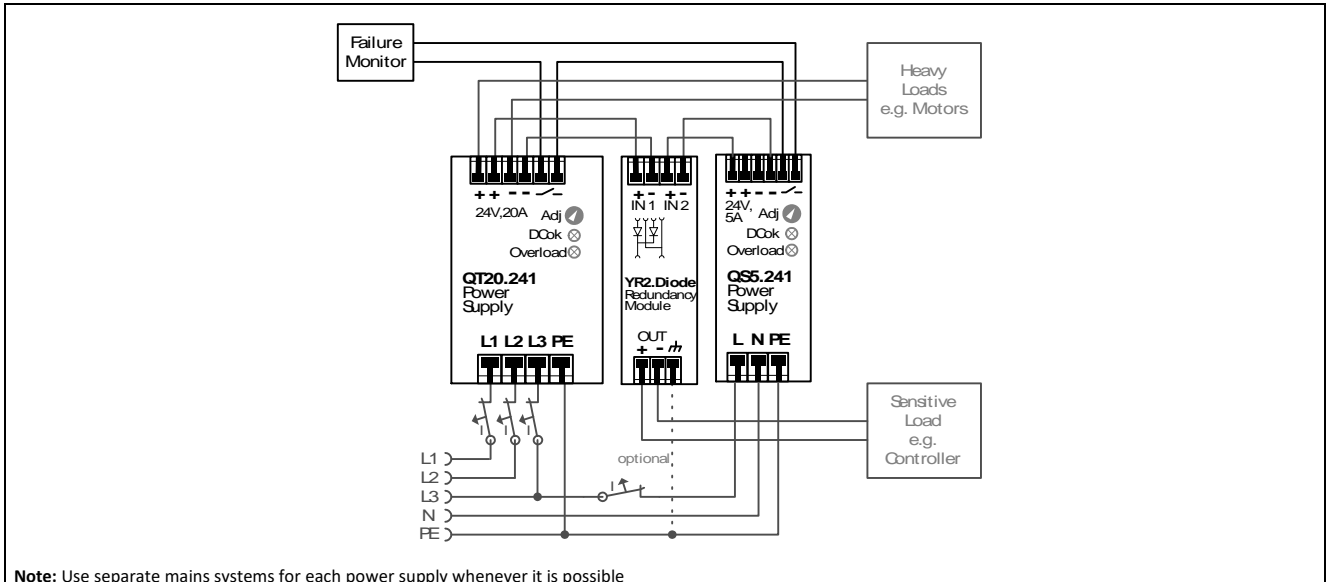

Fig. 18-4 Wiring diagram, redundancy for sensitive loads



18.7. EXAMPLE: DECOUPLING OF BRANCHES

Buffer energy supplied from a DC-UPS or buffer module is not wasted in "power branches".

Please note:

Set output voltage of the power supply to a level that the buffer unit or DC-UPS will not start unexpected. Take the voltage drop of the YR2.DIODE into account.

Fig. 18-5 Wiring diagram, decoupling of buffered branches

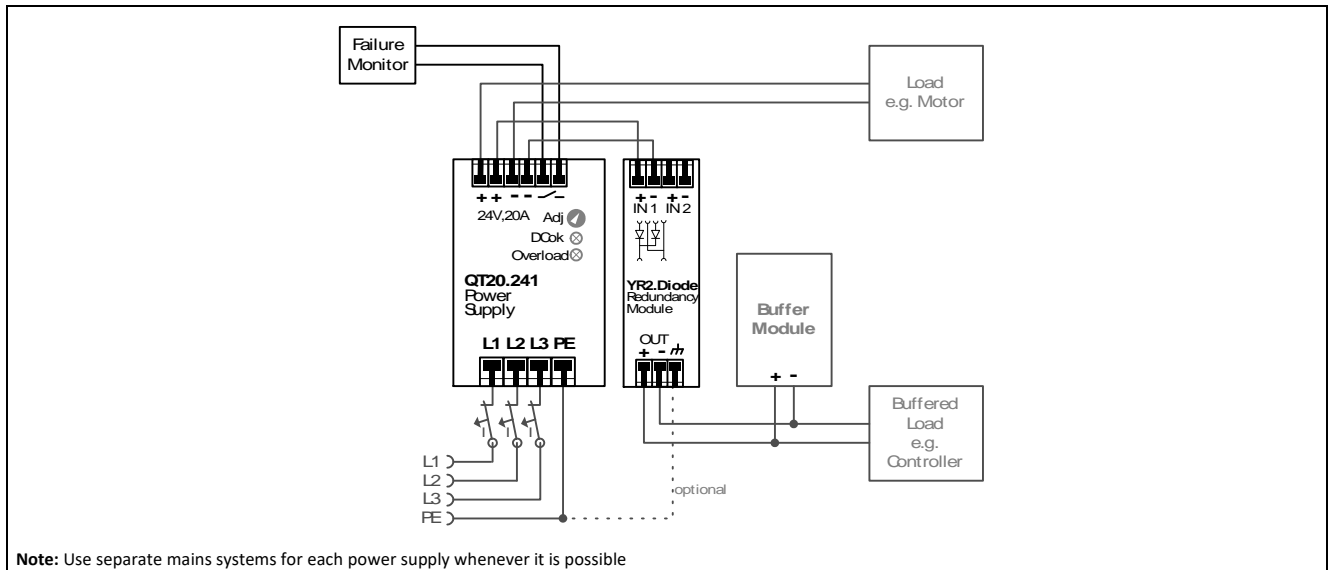

18.8. USE IN A TIGHTLY SEALED ENCLOSURE

When the redundancy module is installed in a tightly sealed enclosure, the temperature inside the enclosure will be higher than outside. The inside temperature defines the ambient temperature for the redundancy module.

Results from such an installation:

Power supply is placed in the middle of the box, no other heat producer inside the box

Enclosure:	Rittal Typ IP66 Box PK 9516 100, plastic, 110x180x165mm
Load:	24V, 16A; (=80%) load is placed outside the box
Input:	24Vdc
Temperature inside enclosure:	57.8°C (in the middle of the right side of the power supply with a distance of 2cm)
Temperature outside enclosure:	24.6°C
Temperature rise:	33.2K

18.9. MOUNTING ORIENTATIONS

Mounting orientations other than input terminals on the bottom and output on the top require a reduction in continuous output power or a limitation in the maximum allowed ambient temperature.

Fig. 18-6
Mounting Orientation A
(Standard orientation)

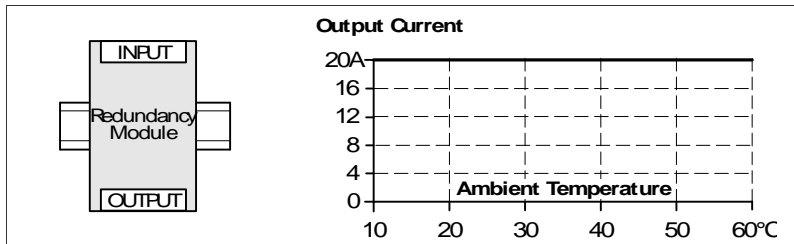

Fig. 18-7
Mounting Orientation B
(Upside down)

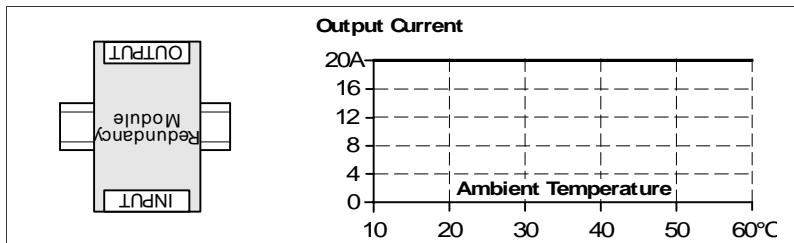

Fig. 18-8
Mounting Orientation C
(Table-top mounting)

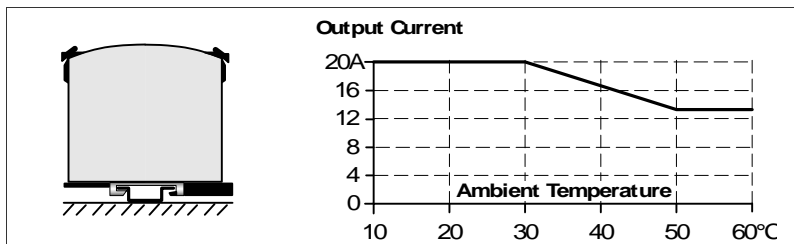

Fig. 18-9
Mounting Orientation D
(Horizontal cw)

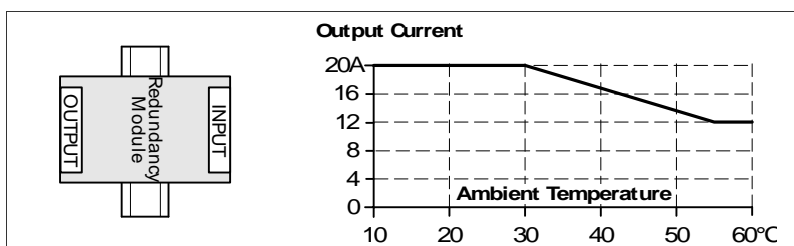

Fig. 18-10
Mounting Orientation E
(Horizontal ccw)

