

Dec.1.2022 Copyright 2022 HIROSE ELECTRIC CO., LTD. All Rights Reserved.
In case of consideration for using Automotive equipment / device which demand high reliability, kindly contact our sales window correspondents.

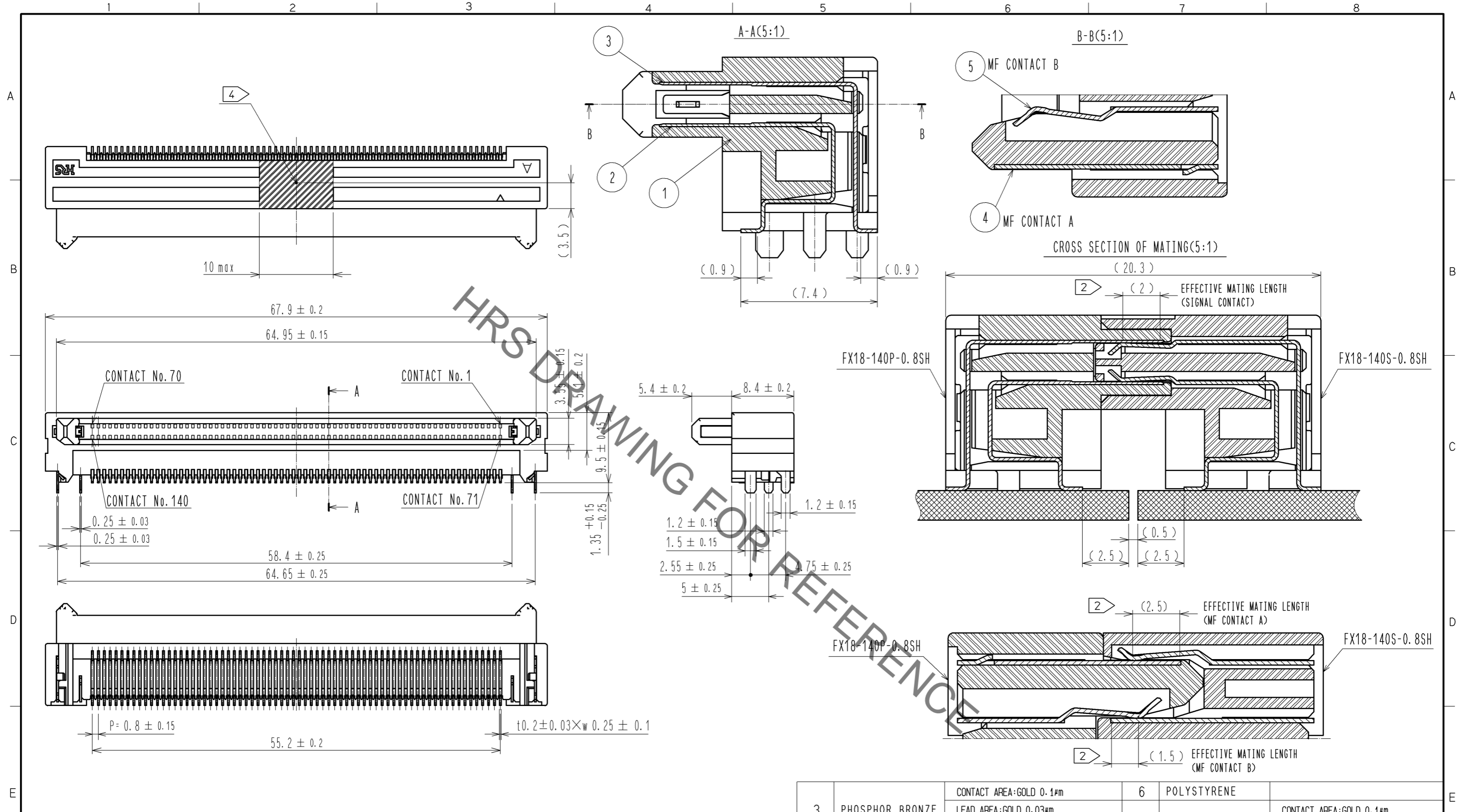

- NOTE 1 LEAD CO-PLANARITY IS 0.1mm MAX.
 ② CONTACTS ARE 3 STEPS SEQUENTIAL. (MF CONTACT A->SIGNAL CONTACT->MF CONTACT B)
 WHEN USING THIS SEQUENTIAL STRUCTURE, PLEASE AVOID ANGLED INSERTION.
 3 MF CONTACT A AND MF CONTACT B CAN BE USED AS POWER SUPPLY CONTACT. (3A/PIN MAX)
 ④ IT SHOWS CONNECTOR'S CENTRE OF GRAVITY AND VACUUM PICKUP AREA.
 ⑤ THIS IS PACKAGED IN TRAY. (40pcs/TRAY)
 6 BLEMISH AND HIT MARK CAN BE OCCURED THROUGH OUT THE MANUFACTURING PROCESS WHICH DOESN' T AFFECT QUALITY LEVEL.
 7 THE DIMENSIONS IN PARENTHESES ARE FOR REFERENCES.

NO.	MATERIAL	FINISH	REMARKS	NO.	MATERIAL	FINISH	REMARKS
3	PHOSPHOR BRONZE	CONTACT AREA:GOLD 0.1µm LEAD AREA:GOLD 0.03µm UNDER PLATING:NICKEL 1.3µm		6	POLYSTYRENE		
2	PHOSPHOR BRONZE	CONTACT AREA:GOLD 0.1µm LEAD AREA:GOLD 0.03µm UNDER PLATING:NICKEL 1.3µm		5	PHOSPHOR BRONZE	CONTACT AREA:GOLD 0.1µm LEAD AREA:TIN-PLATING 1µm UNDER PLATING:NICKEL 1.3µm	
1	POLYAMIDE	BLACK UL94V-0		4	PHOSPHOR BRONZE	CONTACT AREA:GOLD 0.1µm LEAD AREA:TIN-PLATING 1µm UNDER PLATING:NICKEL 1.3µm	

UNITS	SCALE	COUNT	DESCRIPTION OF REVISIONS	DESIGNED	CHECKED	DATE
mm	2 : 1	4	DIS-F-005578	TH. SANO	KI. HIROKAWA	11.07.21

APPROVED	CHECKED	DESIGNED	DRAWN	DRAWING NO.	PART NO.	CODE NO.
HS. OKAWA	KI. HIROKAWA	TH. SANO	TH. SANO	EDC3-159079-00	FX18-140P-0.8SH	CL579-0007-9-00

Dec.1.2022 Copyright 2022 HIROSE ELECTRIC CO., LTD. All Rights Reserved.
In case of consideration for using Automotive equipment / device which demand high reliability, kindly contact our sales window correspondents.

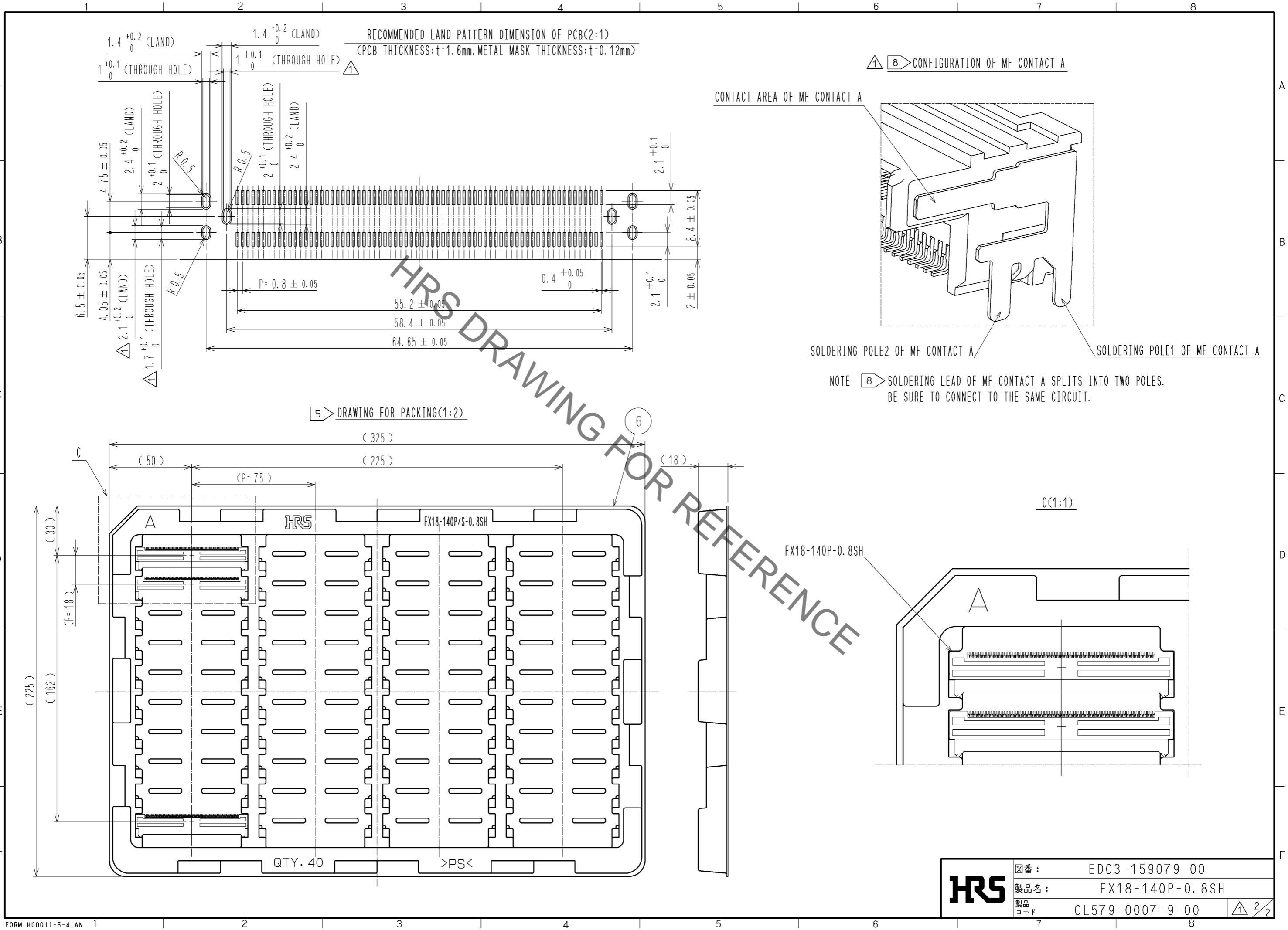

HRS	図番:	EDC3-159079-00	
	製品名:	FX18-140P-0.8SH	
	製品コード:	CL579-0007-9-00	