

Dec.1.2022 Copyright 2022 HIROSE ELECTRIC CO., LTD. All Rights Reserved.
In case of consideration for using Automotive equipment / device which demand high reliability, kindly contact our sales window correspondents.

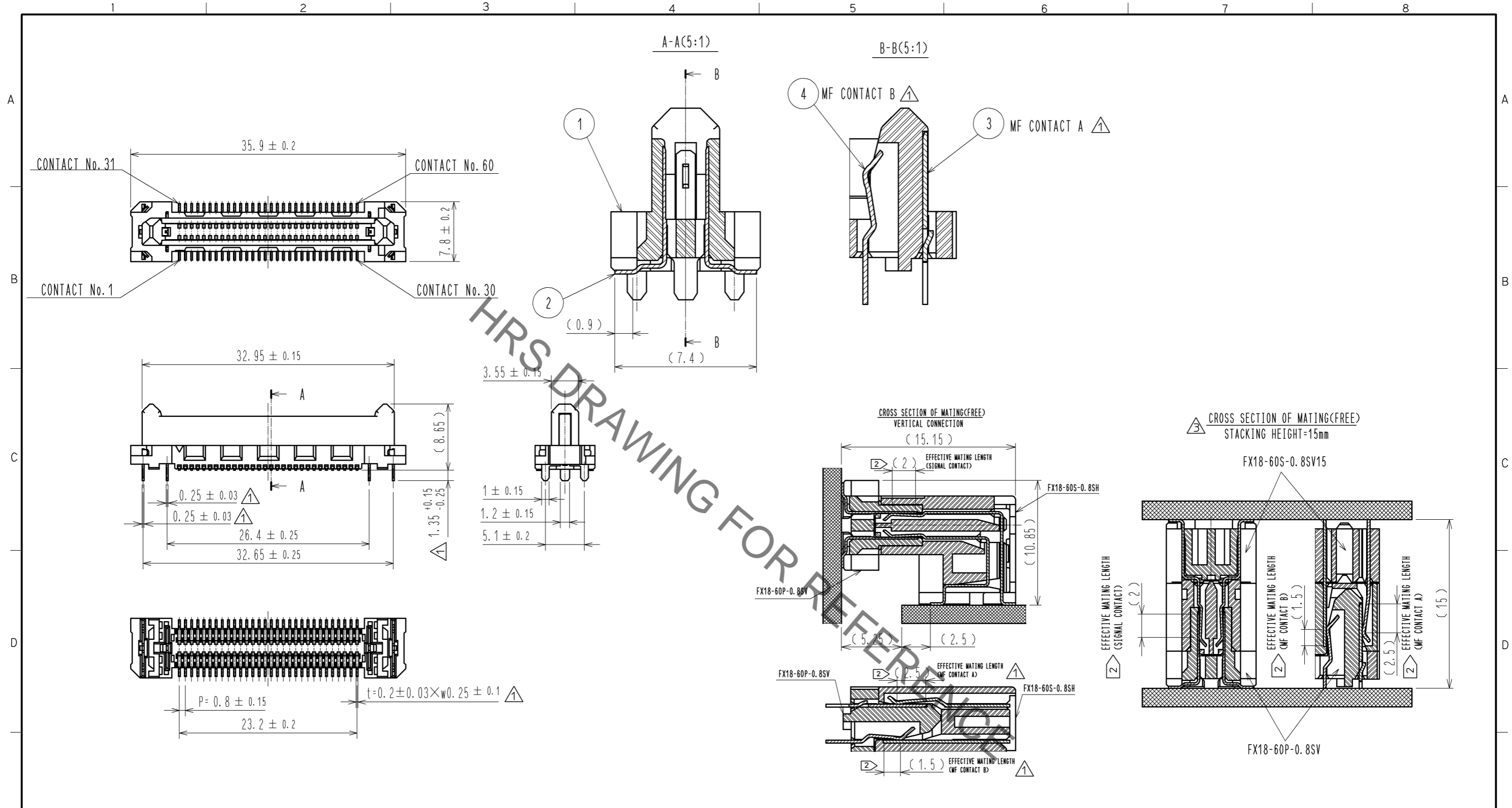

NOTE 1 LEAD CO-PLANARITY IS 0.1mm MAX.
 ② CONTACTS ARE 3 STEPS SEQUENTIAL. (MF CONTACT A=>SIGNAL CONTACT=>MF CONTACT B)
 WHEN USING THIS SEQUENTIAL STRUCTURE, PLEASE AVOID ANGLED INSERTION.
 ③ MF CONTACT A AND MF CONTACT B CAN BE USED AS POWER SUPPLY CONTACT. (3A/PIN MAX)
 ④ IT SHOWS THE VACUUM PICKUP AREA. (SEE PAGE 2)
 REMOVE THE MYLAR TAPE BEFORE MATING CONNECTORS.
 ⑤ THIS IS PACKAGED IN TRAY. (60pcs/TRAY)
 6 BLEMISH AND HIT MARK CAN BE OCCURED THROUGH OUT THE MANUFACTURING PROCESS WHICH DOESN' T AFFECT QUALITY LEVEL.
 7 THE DIMENSIONS IN PARENTHESES ARE FOR REFERENCES.

3	PHOSPHOR BRONZE	CONTACT AREA:GOLD 0.1 μm	6	POLYIMIDE	
		LEAD AREA:TIN-PLATING 1 μm			
		UNDER PLATING:NICKEL 1.3 μm ①			
2	PHOSPHOR BRONZE	CONTACT AREA:GOLD 0.1 μm	5	POLYSTYRENE	
		LEAD AREA:GOLD 0.03 μm			
		UNDER PLATING:NICKEL 1.3 μm ①			
1	POLYAMIDE	BLACK UL94V-0	4	PHOSPHOR BRONZE ①	CONTACT AREA:GOLD 0.1 μm LEAD AREA:TIN-PLATING 1 μm UNDER PLATING:NICKEL 1.3 μm
NO.	MATERIAL	FINISH . REMARKS	NO.	MATERIAL	FINISH . REMARKS
UNITS mm		SCALE 2 : 1	COUNT 1	DESCRIPTION OF REVISIONS DIS-F-005993	
APPROVED : HS. OKAWA 09.04.24			DESIGNED TH. SANO		
CHECKED : HS. OZAWA 09.04.24			CHECKED KI. HIROKAWA		
DESIGNED : KI. HIROKAWA 09.04.24			DATE 12.01.27		
DRAWN : KI. HIROKAWA 09.04.24			DRAWING NO. EDC3-159561-00		
HRS HIROSE ELECTRIC CO., LTD.			PART NO. FX18-60P-0.8SV		
			CODE NO. CL579-0017-2-00		

Dec.1.2022 Copyright 2022 HIROSE ELECTRIC CO., LTD. All Rights Reserved.
 In case of consideration for using Automotive equipment / device which demand high reliability, kindly contact our sales window correspondents.

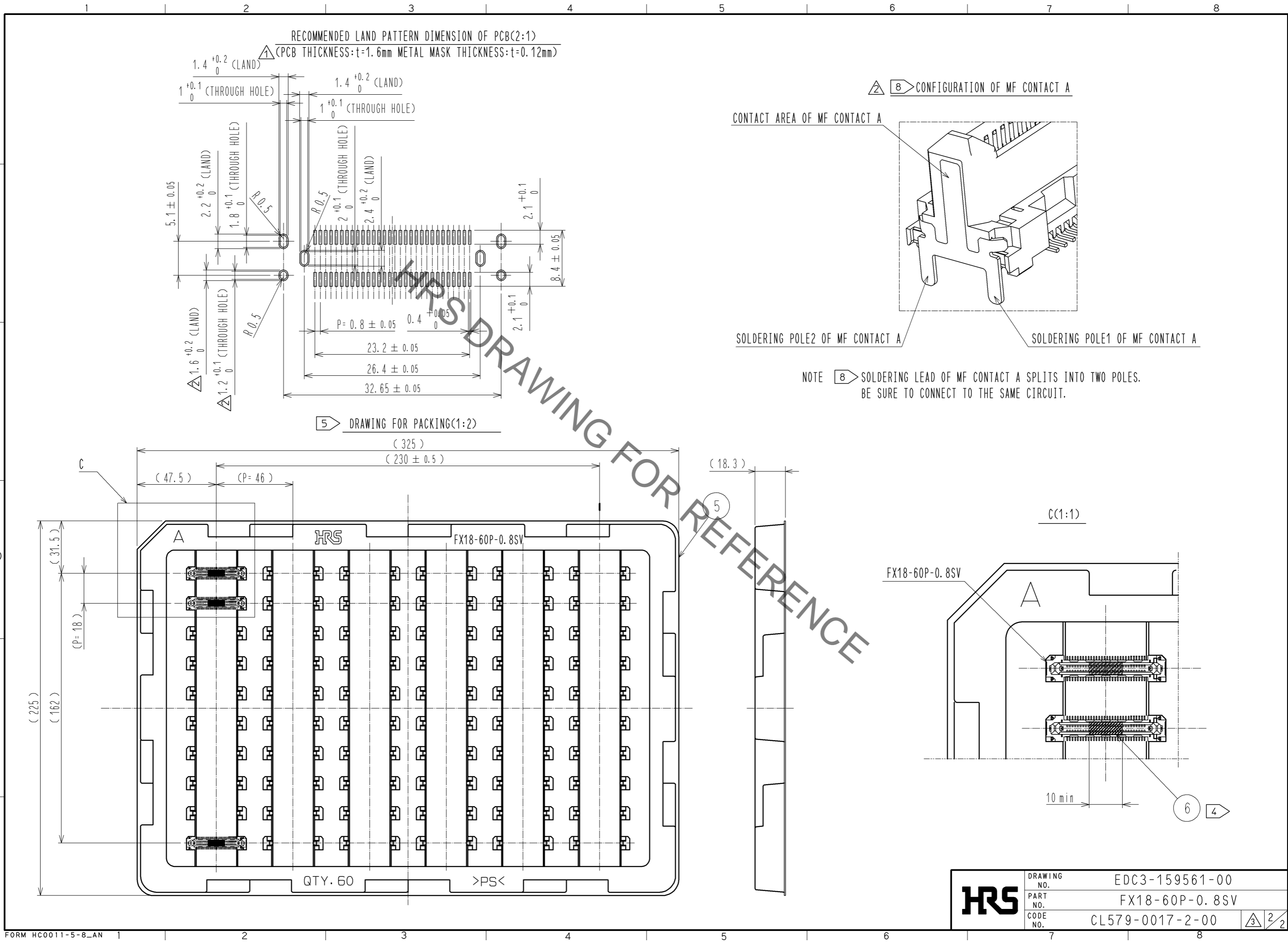

HRS	DRAWING NO.	EDC3-159561-00	3/2
	PART NO.	FX18-60P-0.8SV	
	CODE NO.	CL579-0017-2-00	