

DO NOT SCALE FROM THIS PRINT

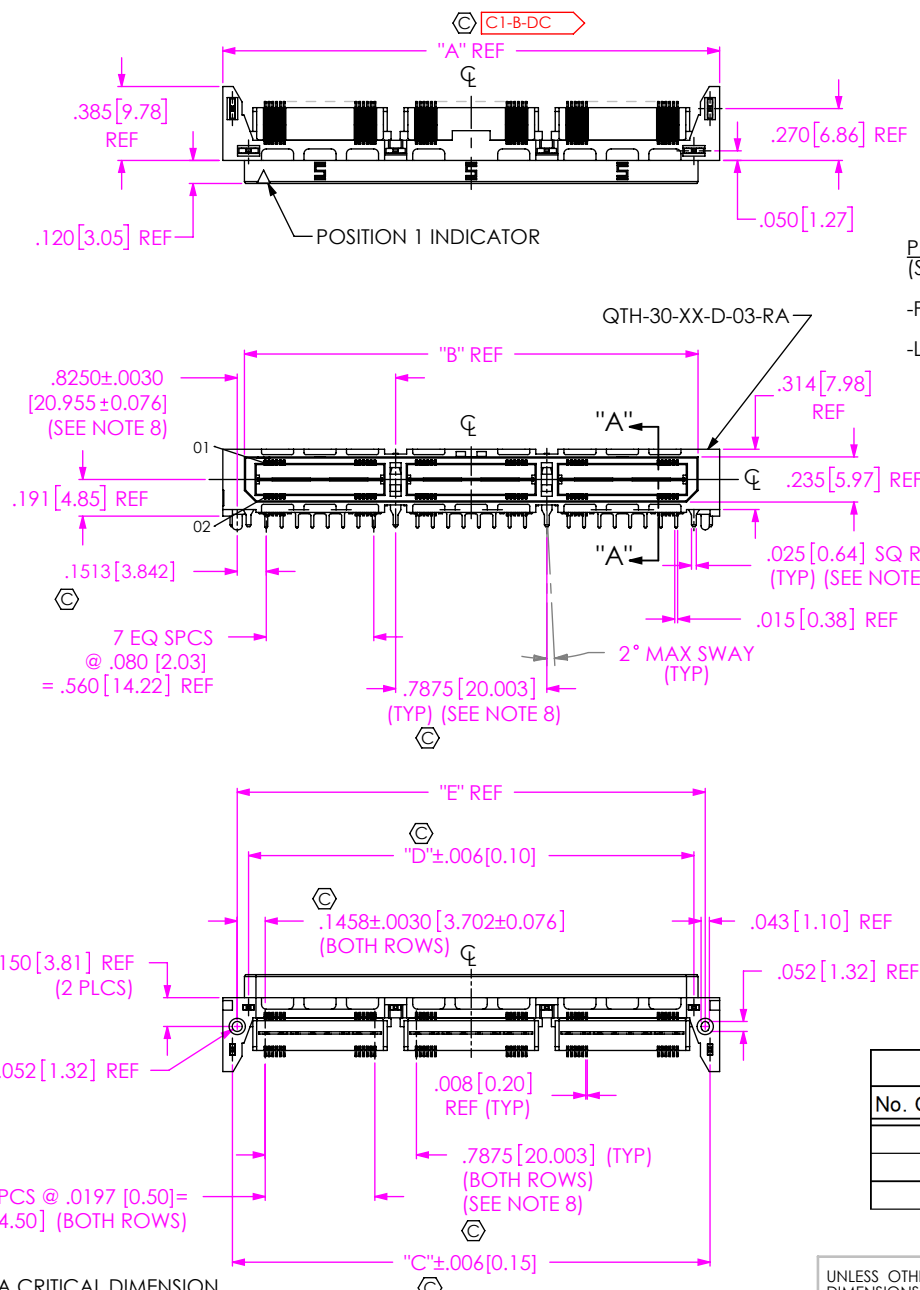

No OF POSITIONS (PER ROW)
-030, -060, -090

LEAD STYLE
-01
(SEE NOTE 12)

PLATING SPECIFICATION
(SEE SHEET 2, TABLE 4)

OPTION

- PGP: PLASTIC GUIDE POSTS (SEE FIG 3, SHT 5)
- *-MGP: METAL GUIDE POSTS (SEE FIG 2, SHT 5)
- K: KAPTON DOT (SEE FIG 5, SHT 6) (USE K-DOT-.276-.375-.005)
- *-LS1: LOCKING SCREW (SEE FIG 4, SHT 6) (FOR MATING WITH QSH-...-RA-..LS1)

-RA: RIGHT ANGLE

ROW SPECIFICATION
-D: DOUBLE

* = NOT TOOLED

-F: 3µ" SELECTIVE GOLD ON CONTACT AREA, MATTE TIN ON TAIL
-L: 10µ" SELECTIVE GOLD ON CONTACT AREA, MATTE TIN ON TAIL

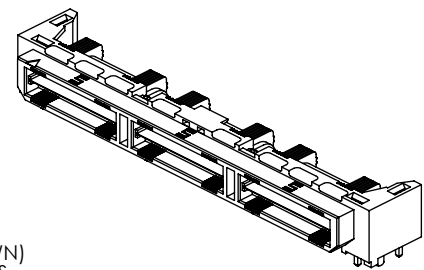
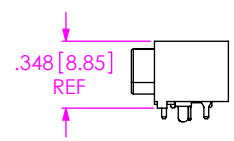

FIG 1
(QTH-090-XXX-D-RA SHOWN)
(SOME CENTER FEATURES REMOVED FOR CLARITY)

TABLE 1

No. OF POS	"A"	"B"	"C"	"D"	"E"
-30	1.013 [25.72]	.787 [20.00]	.913 [23.18]	.745 [18.91]	.862 [21.89]
-60	1.800 [45.72]	1.575 [40.01]	1.700 [43.18]	1.532 [38.91]	1.650 [41.91]
-90	2.588 [65.72]	2.363 [60.01]	2.488 [63.18]	2.320 [58.92]	2.437 [61.90]

- NOTES:
1. Ⓞ REPRESENTS A CRITICAL DIMENSION.
 2. BURR ALLOWANCE: .0010 MAX.
 3. MINIMUM PUSHOUT FORCE: SIGNAL: 6 OZ. GROUND PLANE & WELD TABS: 1.0 LB.
 4. IF NEEDED, -L PLATING CAN BE SUBSTITUTED FOR -F PLATING.
 5. MAX TORQUE ON STS-02 TO BE 20 IN-OZ. USE DRIVER COMPATIBLE WITH 61P TORX HEAD.
 6. TIPS OF TERMINALS MAY NOT EXTEND BEYOND THIS SURFACE.
 7. ASSEMBLIES TO BE PACKAGED IN TRAYS.
 8. CENTER WELD TABS ARE NOT AVAILABLE ON -030 & -060 POSITION.
 9. USE -Z- DATUM ZONE ONLY FOR MEASUREMENTS.
 10. DIMENSION TO BE MEASURED ON BOTH ENDS OF THE PART.
 11. SEE APPLICABLE IN-PROCESS VIEW FOR INSPECTION ORIENTATION.
 12. DESIGNED FOR USE WITH A .062 OR .093 PCB.

UNLESS OTHERWISE SPECIFIED, DIMENSIONS ARE IN INCHES. TOLERANCES ARE:

DECIMALS ANGLES

.XX: ±.01 [0.3]
.XXX: ±.005 [0.13]
.XXXX: ±.0020 [0.051]

2°

PROPRIETARY NOTE

THIS DOCUMENT CONTAINS CONFIDENTIAL AND PROPRIETARY INFORMATION AND ALL DESIGN, MANUFACTURING, REPRODUCTION, USE, PATENT RIGHTS AND SALES RIGHTS ARE EXPRESSLY RESERVED BY SAMTEC, INC. THIS DOCUMENT SHALL NOT BE DISCLOSED, IN WHOLE OR PART, TO ANY UNAUTHORIZED PERSON OR ENTITY NOR REPRODUCED, TRANSFERRED OR INCORPORATED IN ANY OTHER PROJECT IN ANY MANNER WITHOUT THE EXPRESS WRITTEN CONSENT OF SAMTEC, INC.



520 PARK EAST BLVD, NEW ALBANY, IN 47150
PHONE: 812-944-6733 FAX: 812-948-5047
e-Mail: info@SAMTEC.com code 55322

MATERIAL: DO NOT SCALE DRAWING SHEET SCALE: 1:1
INSULATOR: LCP UL94V-0, COLOR: BLACK
TERMINAL, GROUND PLANE & WELD TAB: PHOS BRONZE

DESCRIPTION:
.50mm DOUBLE ROW RIGHT ANGLE TERMINAL STRIP

DWG. NO.
QTH-XXX-XX-X-D-RA-XXX

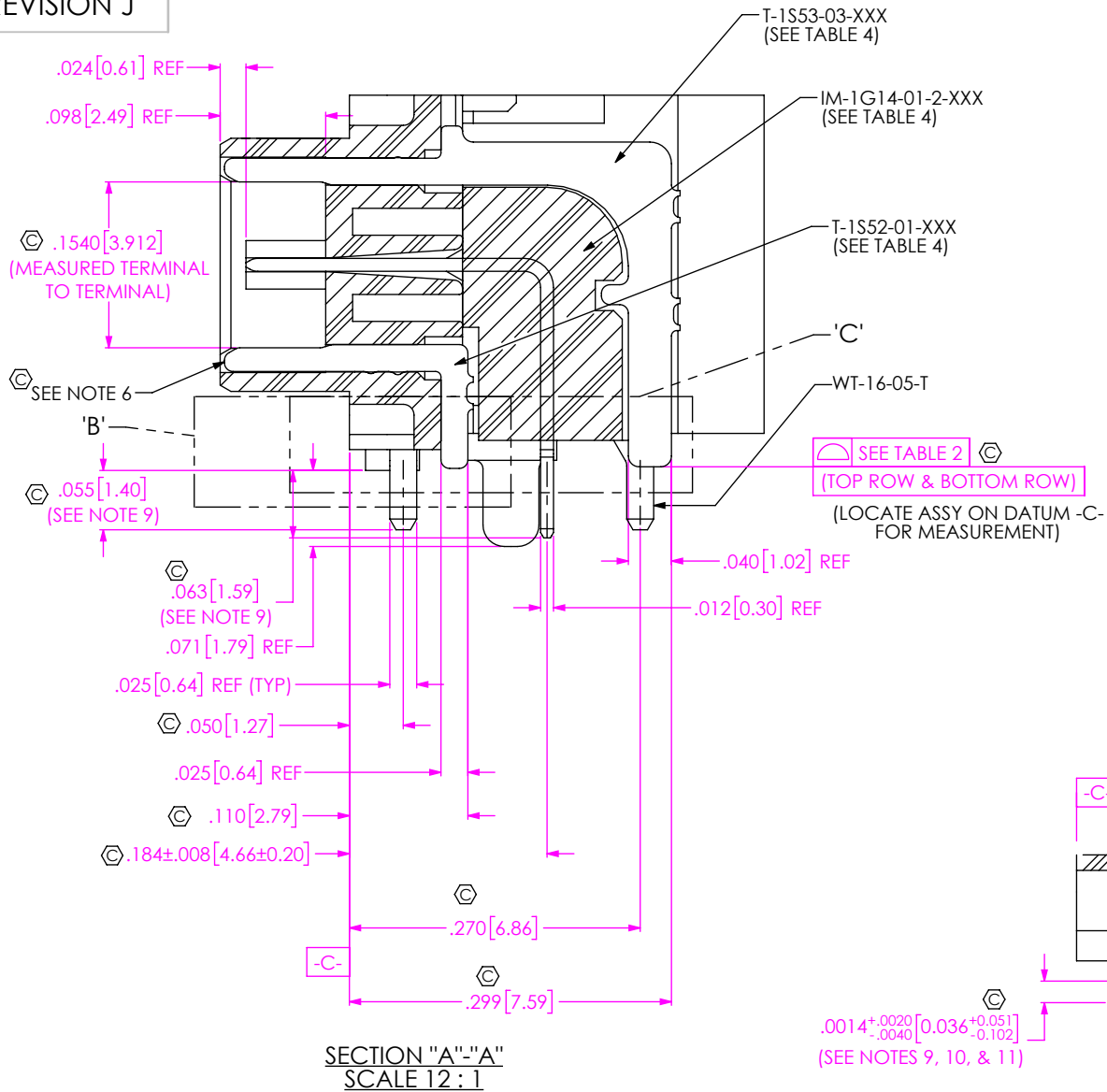

No OF POSITIONS	COPLANARITY	STRAIGHTNESS ROW 1	STRAIGHTNESS ROW 2
-030 THRU -090	.004[0.10]	.004[0.10]	.004[0.10]

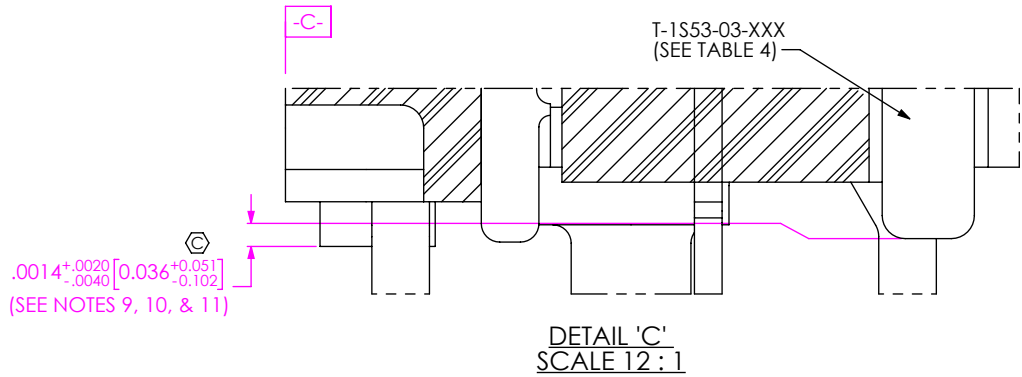
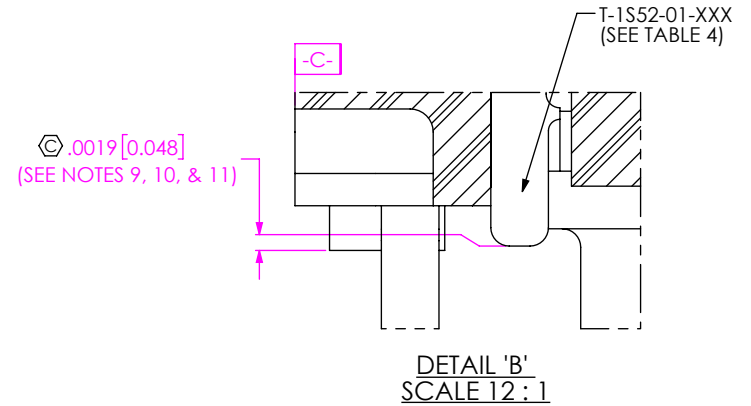

TABLE 4: PLATING SPECIFICATIONS

	T-1S52-01-X CONTACT	T-1S53-03-X CONTACT	IM-1G14-01-2-X GROUND PLANE	WT-16-05-T WELD TAB	WT-74-01-T METAL GUIDE POST
-F	3 - 5µ" MIN. FLASH GOLD ON CONTACT, MATTE TIN TAIL	3 - 5µ" MIN. FLASH GOLD ON CONTACT, MATTE TIN TAIL	3µ" MIN. FLASH GOLD ON CONTACT, MATTE TIN TAIL	MATTE TIN	MATTE TIN
-L	10µ" MIN. LIGHT GOLD ON CONTACT, MATTE TIN TAIL	10µ" MIN. LIGHT GOLD ON CONTACT, MATTE TIN TAIL	10µ" MIN. LIGHT GOLD ON CONTACT, MATTE TIN TAIL	MATTE TIN	MATTE TIN

PROPRIETARY NOTE
 THIS DOCUMENT CONTAINS CONFIDENTIAL AND PROPRIETARY INFORMATION AND ALL DESIGN, MANUFACTURING, REPRODUCTION, USE, PATENT RIGHTS AND SALES RIGHTS ARE EXPRESSLY RESERVED BY SAMTEC, INC. THIS DOCUMENT SHALL NOT BE DISCLOSED, IN WHOLE OR PART, TO ANY UNAUTHORIZED PERSON OR ENTITY NOR REPRODUCED, TRANSFERRED OR INCORPORATED IN ANY OTHER PROJECT IN ANY MANNER WITHOUT THE EXPRESS WRITTEN CONSENT OF SAMTEC, INC.

DO NOT SCALE DRAWING
 SHEET SCALE: 6:1

520 PARK EAST BLVD, NEW ALBANY, IN 47150
 PHONE: 812-944-6733 FAX: 812-948-5047
 e-Mail: info@SAMTEC.com code 55322

DESCRIPTION:
 .50mm DOUBLE ROW RIGHT ANGLE TERMINAL STRIP

DWG. NO.
 QTH-XXX-XX-X-D-RA-XXX

BY: DUKES Z 02/13/2010 SHEET 2 OF 6

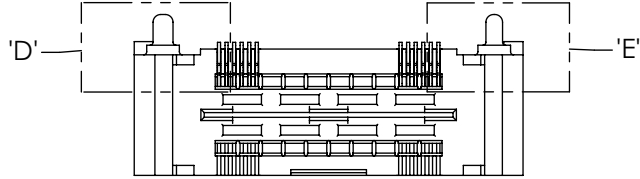
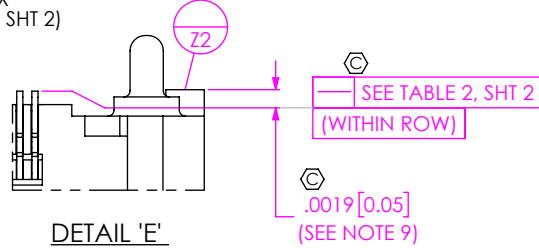
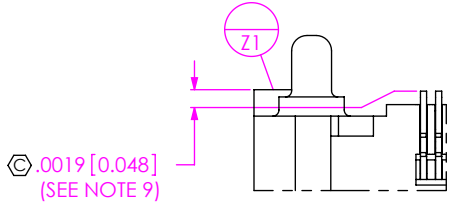
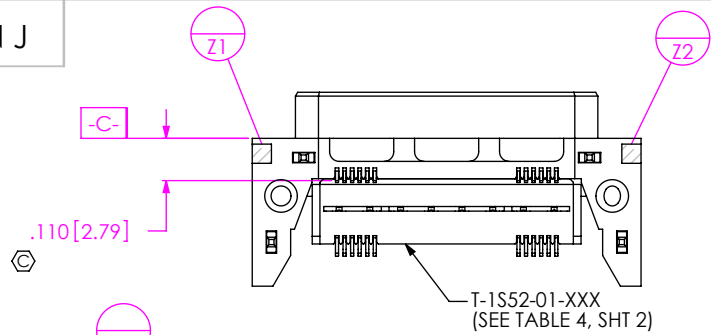

INSPECTION VIEW 1
(FILL BOTTOM ROW)

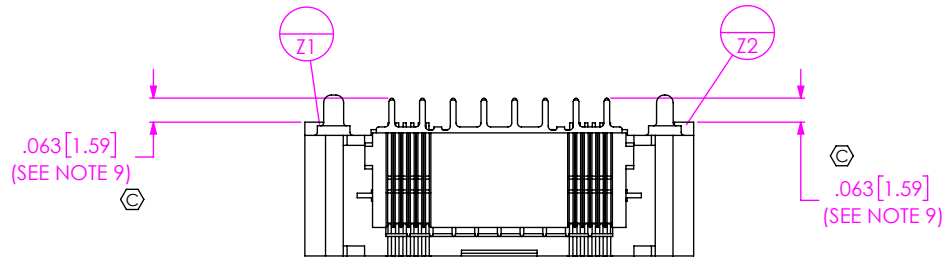
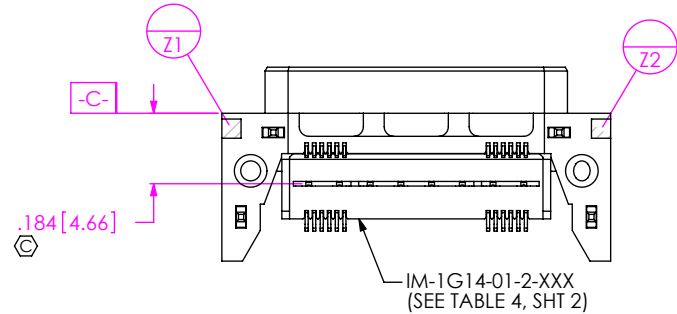

INSPECTION VIEW 2
(FILL IM-1G14)

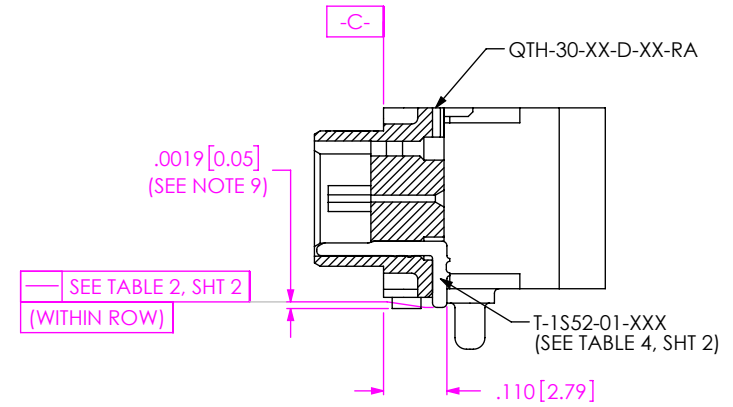

IN-PROCESS 1
(FILL BOTTOM ROW)
(SEE INSPECTION VIEW 1 FOR ORIENTATION AND CPC'S)

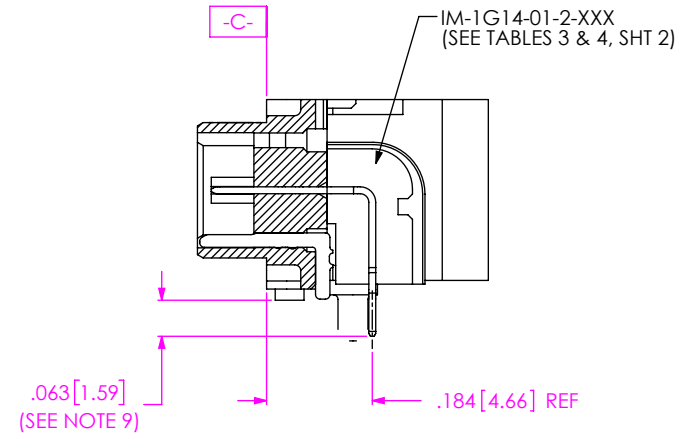

IN-PROCESS 2
(FILL IM-1G14)
(SEE INSPECTION VIEW 2 FOR ORIENTATION AND CPC'S)

PROPRIETARY NOTE

THIS DOCUMENT CONTAINS CONFIDENTIAL AND PROPRIETARY INFORMATION AND ALL DESIGN, MANUFACTURING, REPRODUCTION, USE, PATENT RIGHTS AND SALES RIGHTS ARE EXPRESSLY RESERVED BY SAMTEC, INC. THIS DOCUMENT SHALL NOT BE DISCLOSED, IN WHOLE OR PART, TO ANY UNAUTHORIZED PERSON OR ENTITY NOR REPRODUCED, TRANSFERRED OR INCORPORATED IN ANY OTHER PROJECT IN ANY MANNER WITHOUT THE EXPRESS WRITTEN CONSENT OF SAMTEC, INC.

DO NOT SCALE DRAWING

SHEET SCALE: 6:1



520 PARK EAST BLVD. NEW ALBANY, IN 47150
PHONE: 812-944-6733 FAX: 812-948-5047
e-Mail info@SAMTEC.com code 55322

DESCRIPTION:
.50mm DOUBLE ROW RIGHT ANGLE TERMINAL STRIP

DWG. NO.
QTH-XXX-XX-X-D-RA-XXX

BY: DUKES Z 02/13/2010 SHEET 3 OF 6

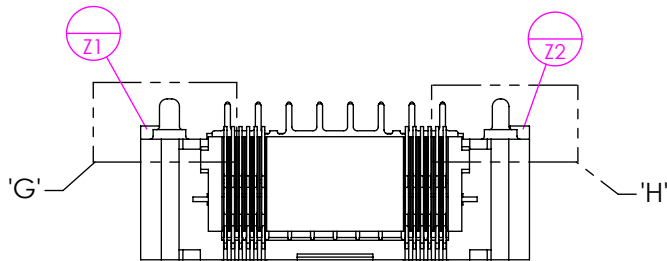
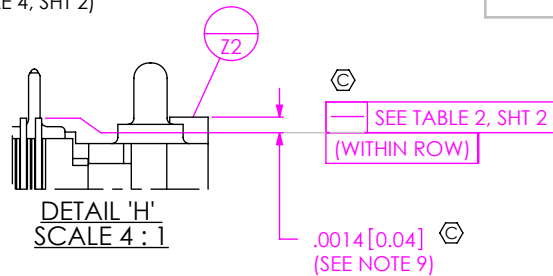
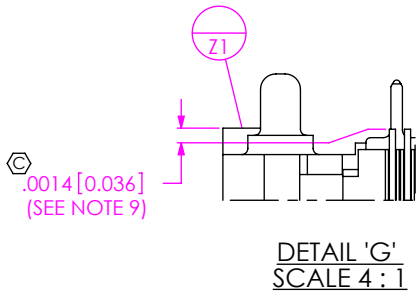
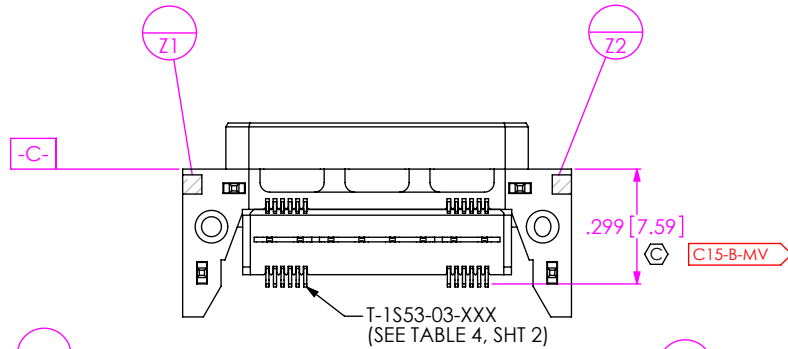
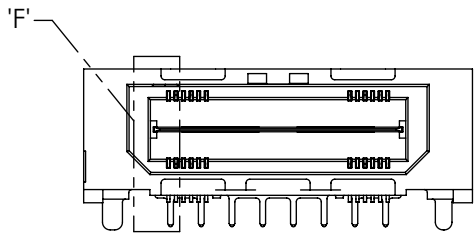

INSPECTION VIEW 3
(FILL TOP ROW)

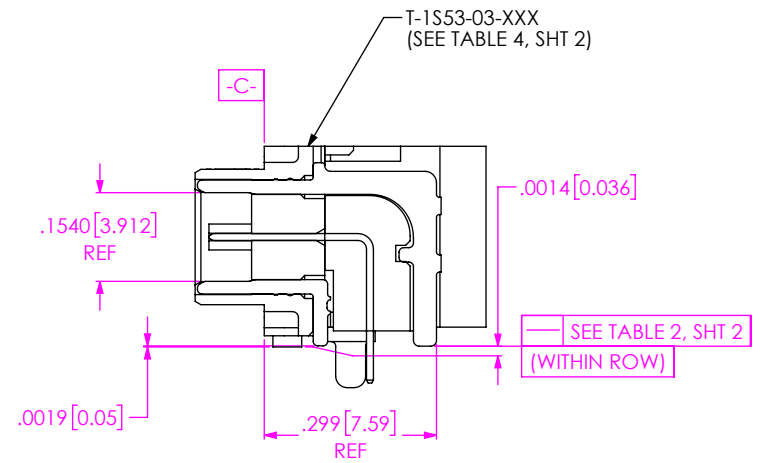

IN-PROCESS 3
(FILL TOP ROW)
(SEE INSPECTION VIEW 3 FOR ORIENTATION AND CPC'S)

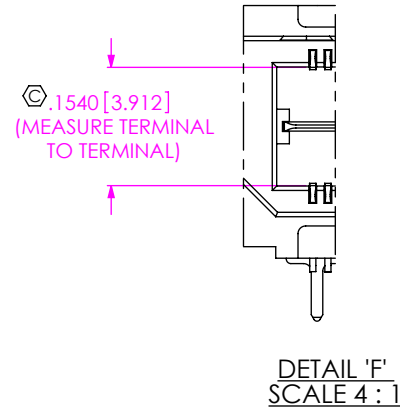

PROPRIETARY NOTE
THIS DOCUMENT CONTAINS CONFIDENTIAL AND PROPRIETARY INFORMATION AND ALL DESIGN, MANUFACTURING, REPRODUCTION, USE, PATENT RIGHTS AND SALES RIGHTS ARE EXPRESSLY RESERVED BY SAMTEC, INC. THIS DOCUMENT SHALL NOT BE DISCLOSED, IN WHOLE OR PART, TO ANY UNAUTHORIZED PERSON OR ENTITY NOR REPRODUCED, TRANSFERRED OR INCORPORATED IN ANY OTHER PROJECT IN ANY MANNER WITHOUT THE EXPRESS WRITTEN CONSENT OF SAMTEC, INC.

DO NOT SCALE DRAWING

SHEET SCALE: 6:1



520 PARK EAST BLVD, NEW ALBANY, IN 47150
PHONE: 812-944-6733 FAX: 812-948-5047
e-Mail info@SAMTEC.com code 55322

DESCRIPTION:
.50mm DOUBLE ROW RIGHT ANGLE TERMINAL STRIP

DWG. NO.
QTH-XXX-XX-X-D-RA-XXX

BY: DUKES Z 02/13/2010 SHEET 4 OF 6

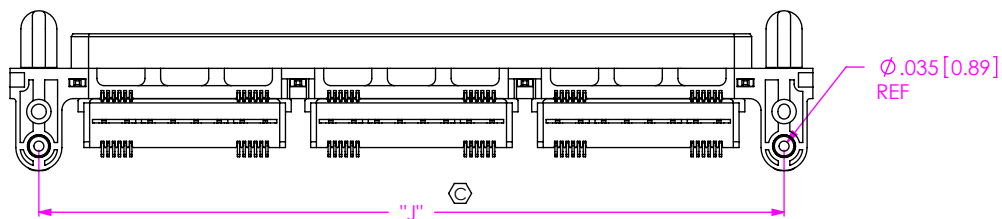
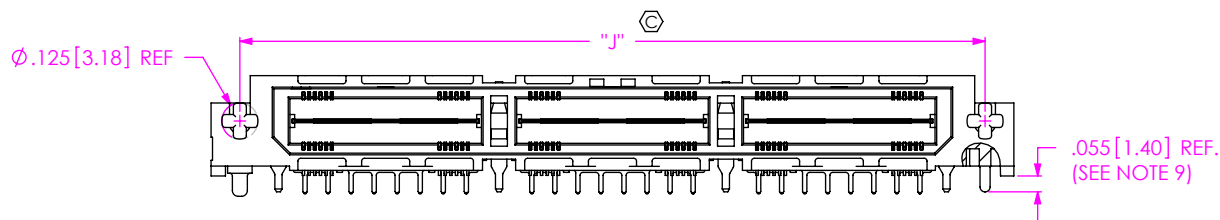
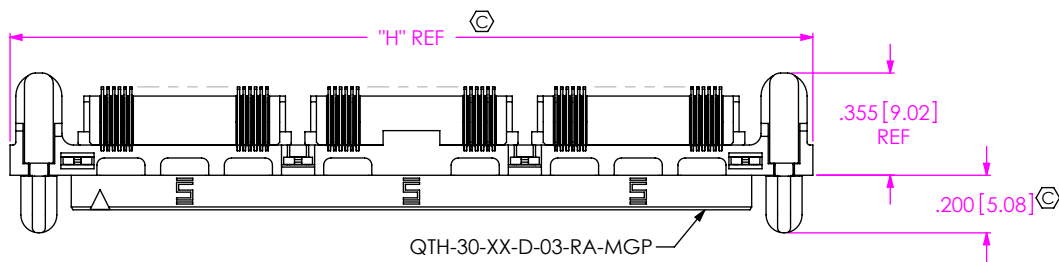

TABLE 5		
NO OF POS	"H"	"J"
-30	1.213 [30.80]	1.013 [25.72]
-60	2.000 [50.80]	1.800 [45.72]
-90	2.788 [70.80]	2.588 [65.72]

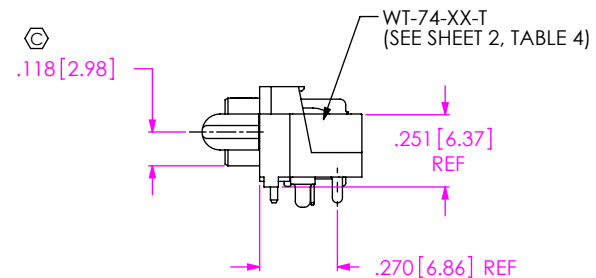

FIG 2
QTH-090-01-XXX-D-RA-MGP SHOWN
(SAME AS FIG 1, EXCEPT AS SHOWN)
(SOME CENTER FEATURES REMOVED FOR CLARITY)
(NOT TOOLED)

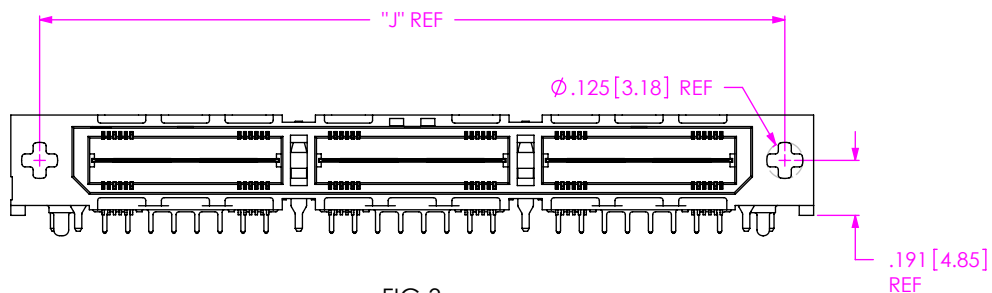
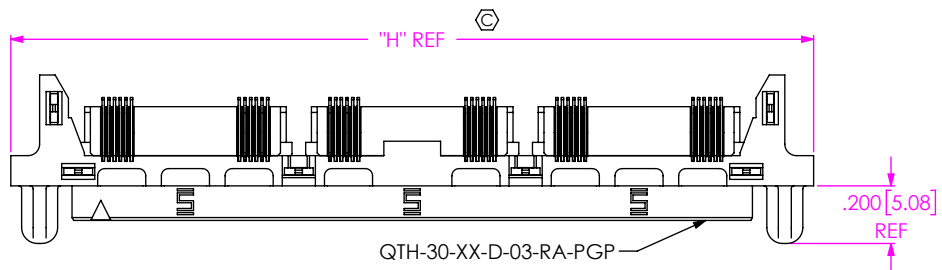

FIG 3
QTH-090-01-XXX-D-RA-PGP SHOWN
(SAME AS FIG 1, EXCEPT AS SHOWN)
(SOME CENTER FEATURES REMOVED FOR CLARITY)

PROPRIETARY NOTE
THIS DOCUMENT CONTAINS CONFIDENTIAL AND PROPRIETARY INFORMATION AND ALL DESIGN, MANUFACTURING, REPRODUCTION, USE, PATENT RIGHTS AND SALES RIGHTS ARE EXPRESSLY RESERVED BY SAMTEC, INC. THIS DOCUMENT SHALL NOT BE DISCLOSED, IN WHOLE OR PART, TO ANY UNAUTHORIZED PERSON OR ENTITY NOR REPRODUCED, TRANSFERRED OR INCORPORATED IN ANY OTHER PROJECT IN ANY MANNER WITHOUT THE EXPRESS WRITTEN CONSENT OF SAMTEC, INC.

DO NOT SCALE DRAWING

SHEET SCALE: 2:1



520 PARK EAST BLVD, NEW ALBANY, IN 47150
PHONE: 812-944-6733 FAX: 812-948-5047
e-Mail: info@SAMTEC.com code 55322

DESCRIPTION:
.50mm DOUBLE ROW RIGHT ANGLE TERMINAL STRIP

DWG. NO.
QTH-XXX-XX-X-D-RA-XXX

BY: DUKES Z 02/13/2010 SHEET 5 OF 6

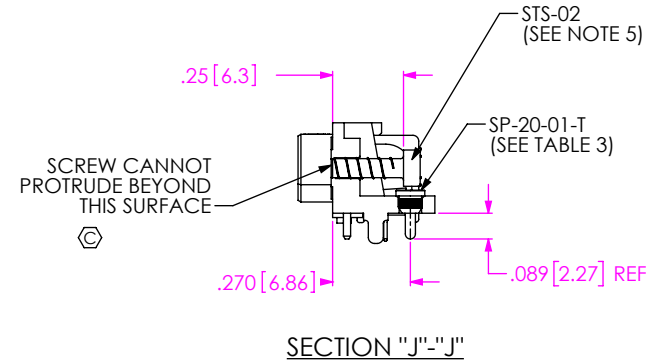
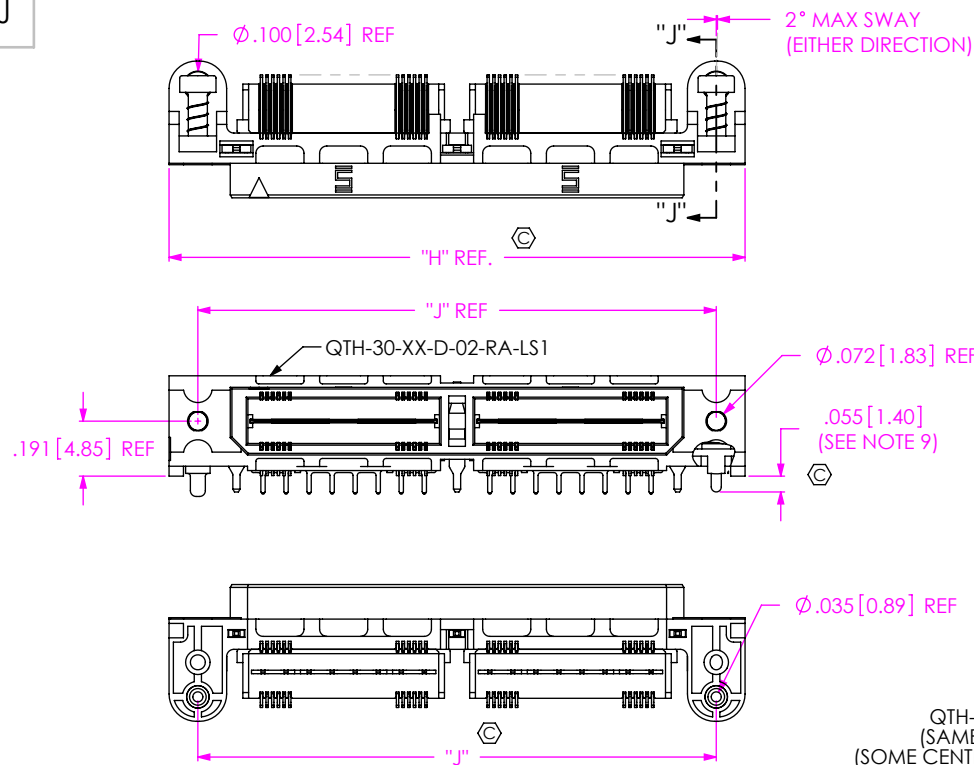

FIG 4
QTH-060-01-XXX-D-RA-LS1 SHOWN
(SAME AS FIG 1, EXCEPT AS SHOWN)
(SOME CENTER FEATURES REMOVED FOR CLARITY)
(NOT TOOLED)

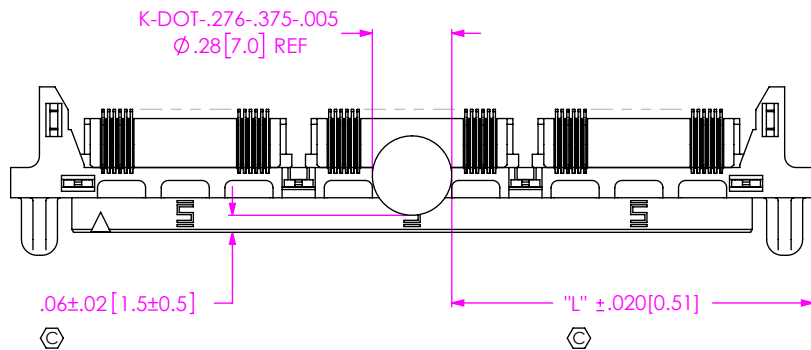

FIG 5
QTH-090-01-XXX-D-RA-PGP-K SHOWN
(SAME AS FIG 1, EXCEPT AS SHOWN)
(SOME CENTER FEATURES REMOVED FOR CLARITY)

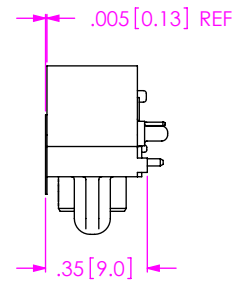

TABLE 7		
NO OF POS	"L"	
	*-MGP & -PGP & *-LS1	NO GUIDE POSTS
-30	.469 [11.91]	.369 [9.37]
-60	.862 [21.89]	.762 [19.35]
-90	1.256 [31.90]	1.156 [29.36]

PROPRIETARY NOTE
THIS DOCUMENT CONTAINS CONFIDENTIAL AND PROPRIETARY INFORMATION AND ALL DESIGN, MANUFACTURING, REPRODUCTION, USE, PATENT RIGHTS AND SALES RIGHTS ARE EXPRESSLY RESERVED BY SAMTEC, INC. THIS DOCUMENT SHALL NOT BE DISCLOSED, IN WHOLE OR PART, TO ANY UNAUTHORIZED PERSON OR ENTITY NOR REPRODUCED, TRANSFERRED OR INCORPORATED IN ANY OTHER PROJECT IN ANY MANNER WITHOUT THE EXPRESS WRITTEN CONSENT OF SAMTEC, INC.

DO NOT SCALE DRAWING
SHEET SCALE: 1:0.666667



520 PARK EAST BLVD, NEW ALBANY, IN 47150
PHONE: 812-944-6733 FAX: 812-948-5047
e-Mail info@SAMTEC.com code 55322

DESCRIPTION:
.50mm DOUBLE ROW RIGHT ANGLE TERMINAL STRIP

DWG. NO.
QTH-XXX-XX-X-D-RA-XXX

BY: DUKES Z 02/13/2010 SHEET 6 OF 6