

D

# REVISION HISTORY

## Schematics Index:

- P01: REVISION HISTORY
- P02: BLOCK
- P03: POWER TREE
- P04: GPIO ASSIGNMENT
- P05: POWER
- P06: CPU
- P07: JTAG/DEBUG
- P08: DDR3\_16X1
- P09: eMMC/BOOTSEL
- P10: MIPI LCD
- P11: MIPI CSI
- P12: CARD/USB
- P13: RS485
- P14: RMII
- P15:4G

C

B

A

Revision	Description	Date	Drawn	Checked
Ver 0.1	Initial Version	2022-11-29	QIAO	

	Project Name		<b>V853 PRO</b>	
	Design Name		<b>Block</b>	
	Size A3	ERP Code	Date: Friday, December 02, 2022	Rev V1.0
Date: Friday, December 02, 2022			Sheet 1 of 15	

D

C

B

A

5

4

3

2

1

5

4

3

2

1

32.768KHz 24MHz

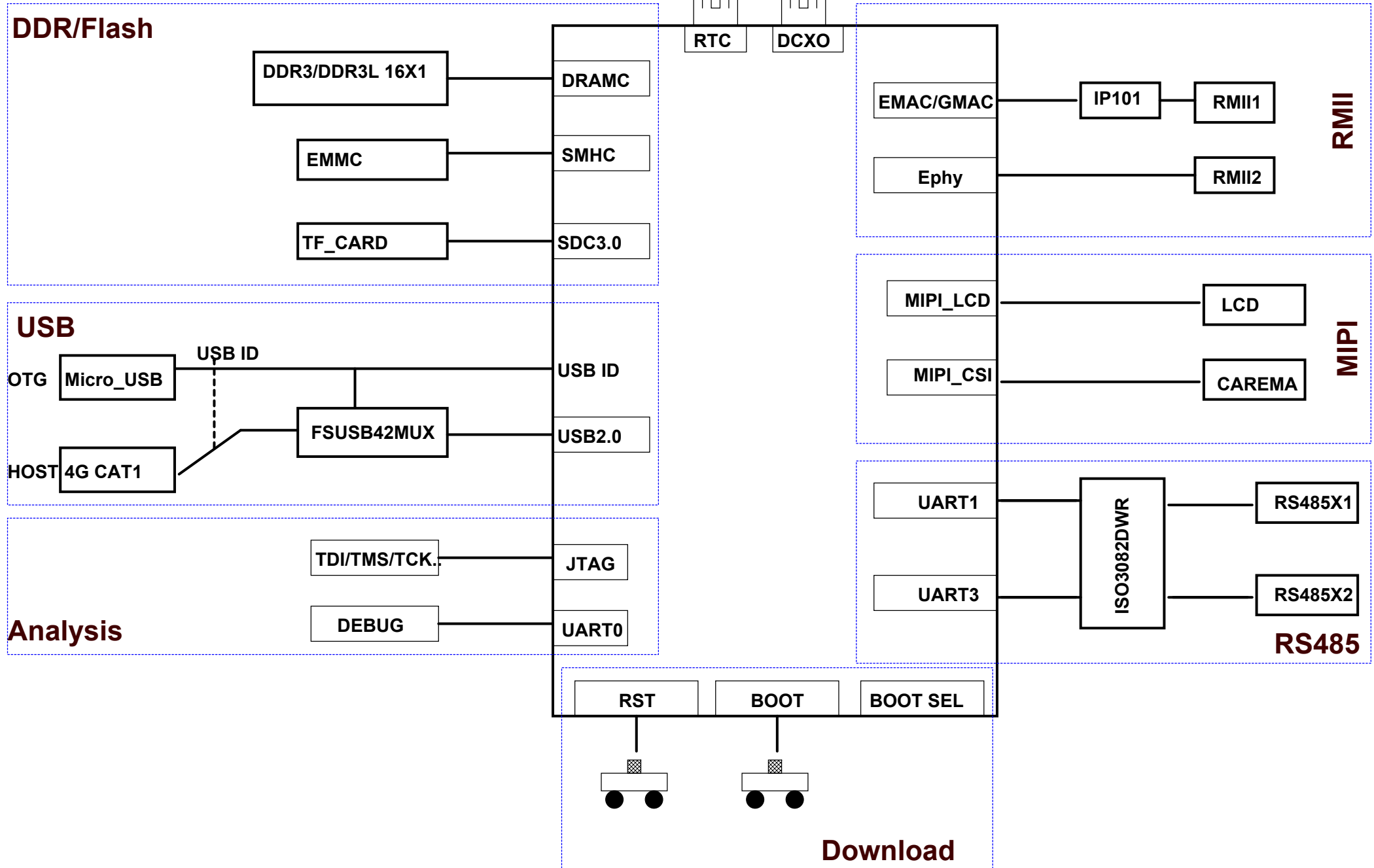

# POWER TREE

  DEFAULT POWER ON  
  DEFAULT POWER OFF

## AXP2101

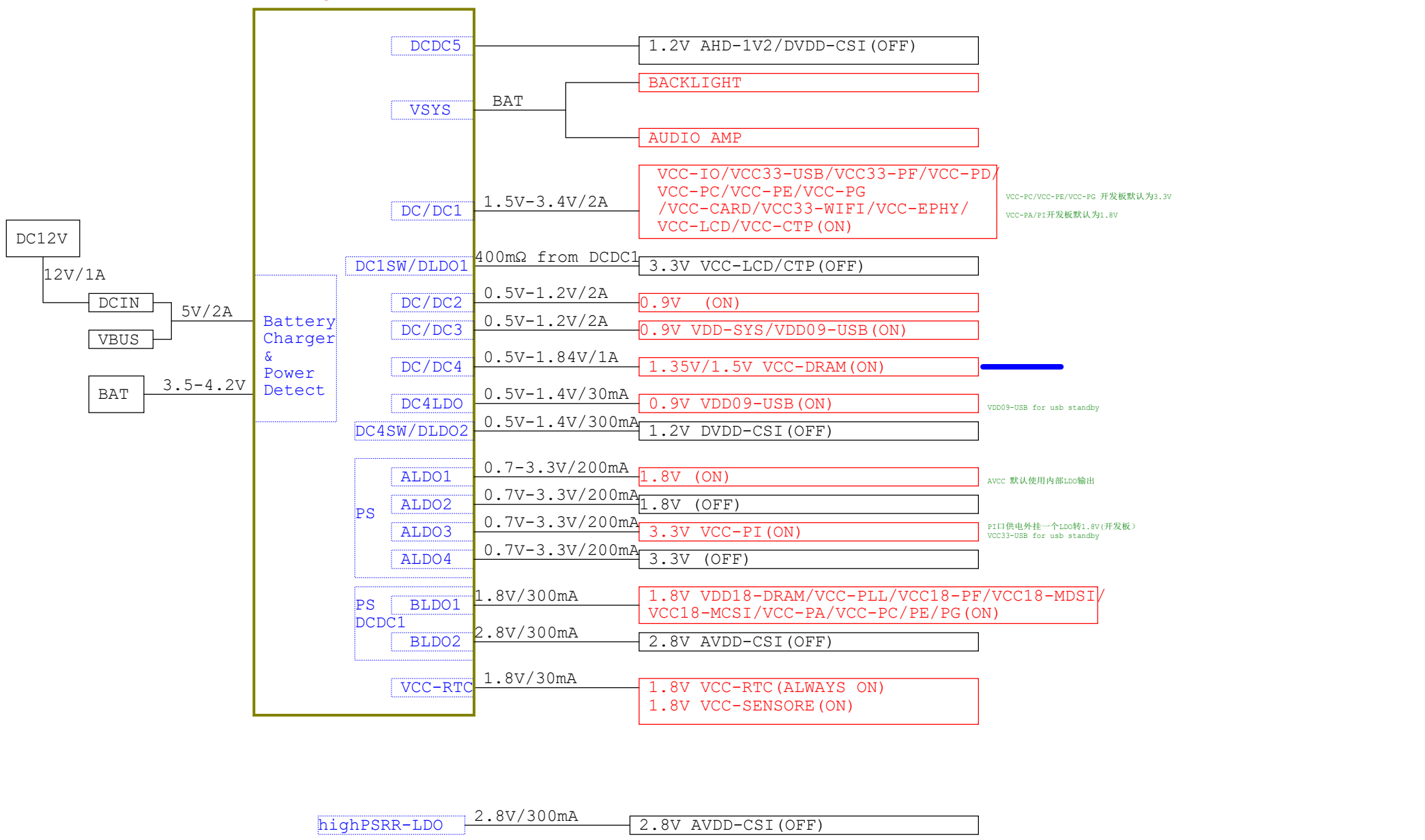

## GPIO ASSIGNMENT

1. RS485_CTRL1 :	AB2
2. RS485_CTRL2 :	W3
3. RST_WIR :	W4
4. CAT_ON :	W5
5. CARD-PWROFF :	V22

	Project Name		
	<b>V853 PRO</b>		
	Design Name		
<b>GPIO_CTRL</b>			
Size	ERP Code	Rev	
A3		V1.0	
Date:	Friday, December 02, 2022	Sheet 4 of 15	

# VBAT&SUPER CAP

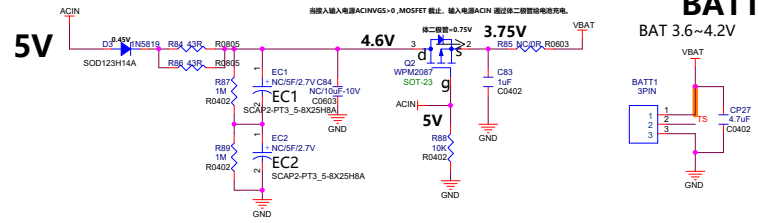

# Pwr in

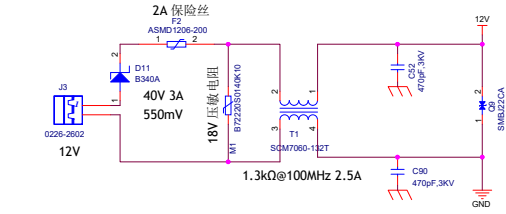

# 12V BUCK

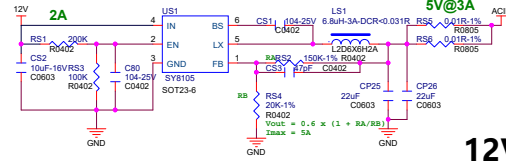

# 12V-5V

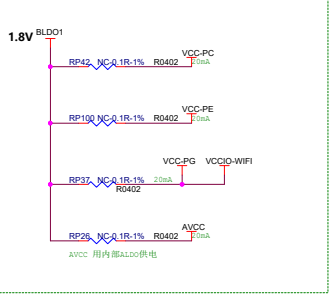
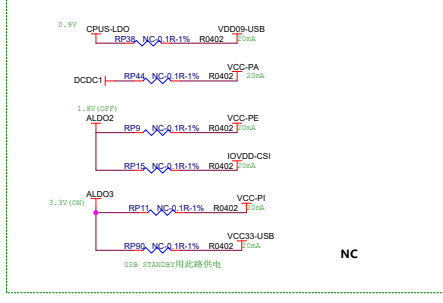
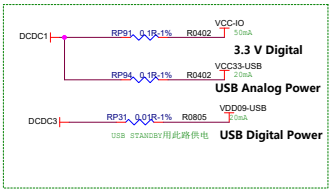
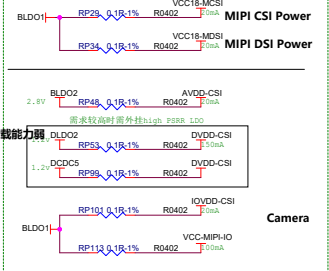
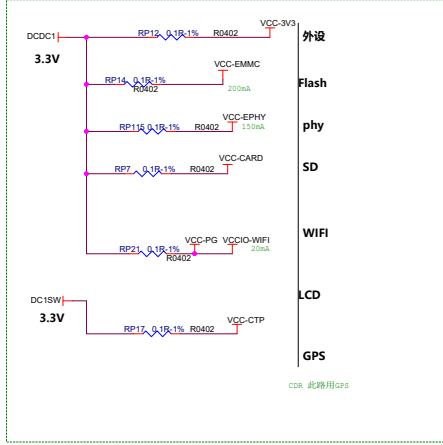
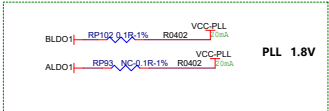
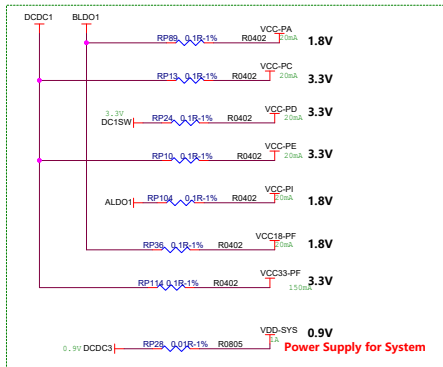

# AXP2101

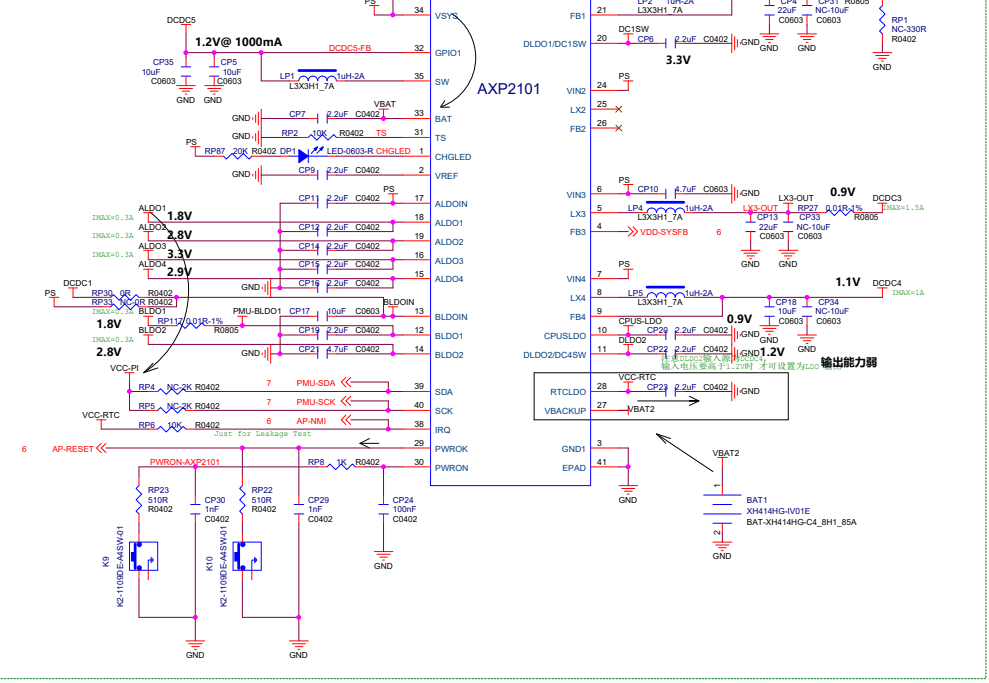

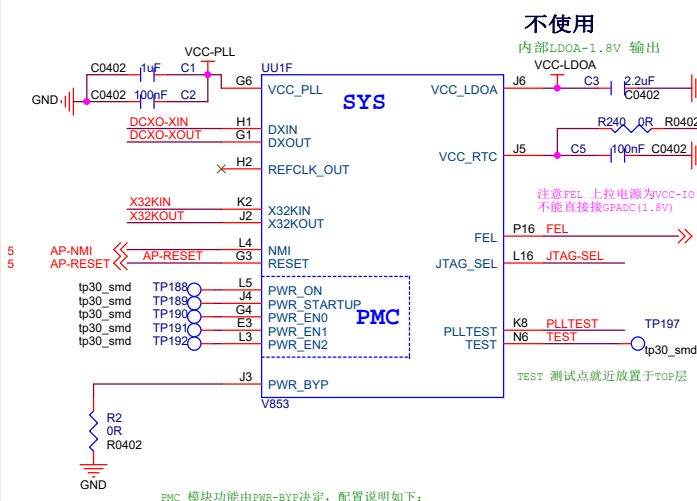
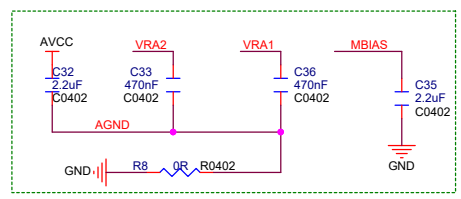
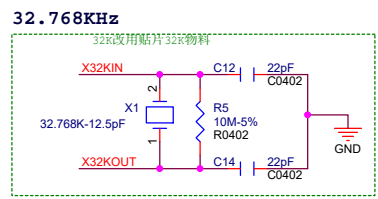
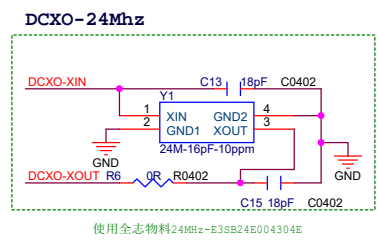
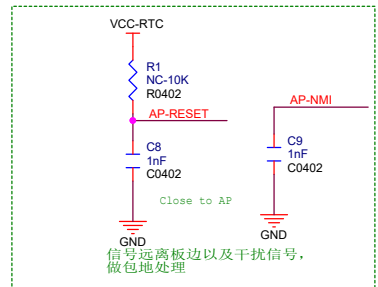

RESET-BYP	浮空为高电平
	接地为低电平

PMC 模块功能由PWR-BYP决定, 配置说明如下:  
1. PMC 功能PIN有效;  
2. 上电内部复位有效 (需要外接高电平);  
3. 工作时支持外部复位PMC来复位SOC;  
1. PMC 功能PIN无效; 只有NMI/RESET信号有效;  
2. 上电内部复位有效; 也可外接PMU PWROR信号复位;  
3. 工作时支持外部复位;

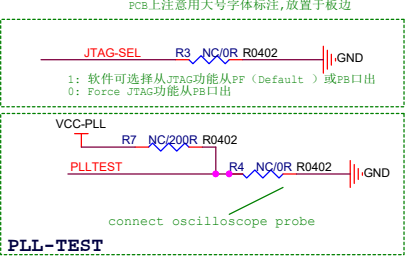
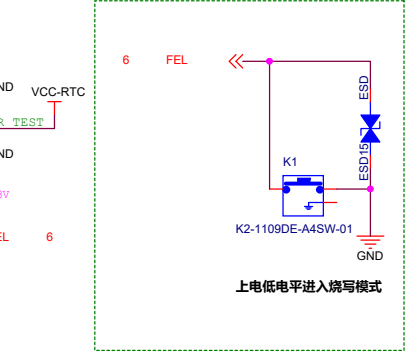
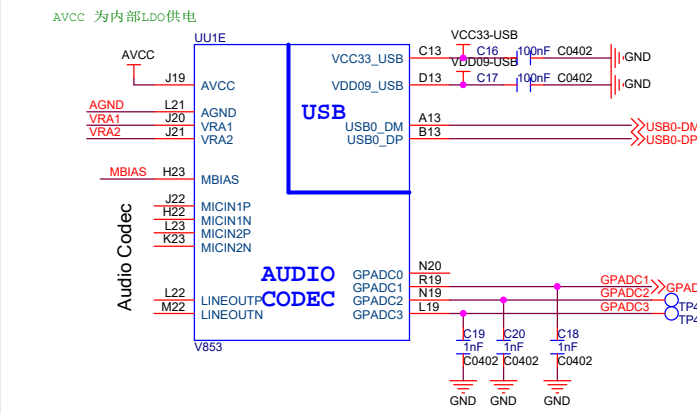

# SCREW HOLES

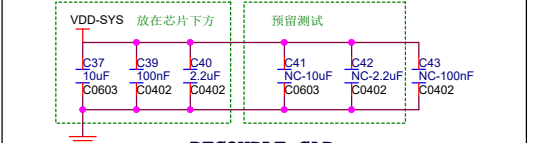
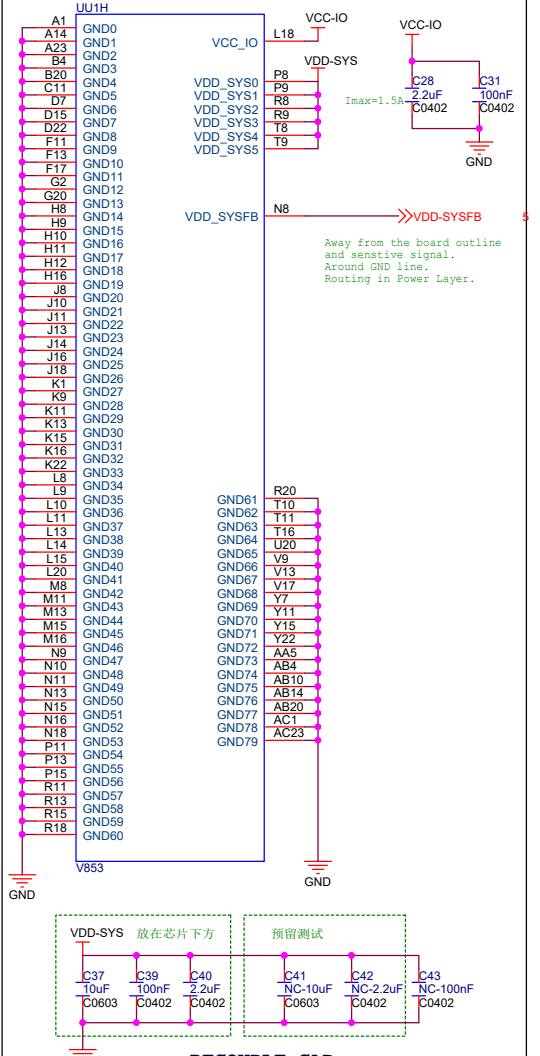
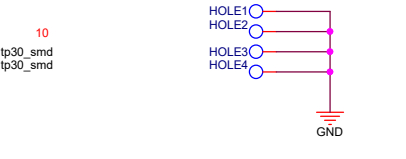

# SOC

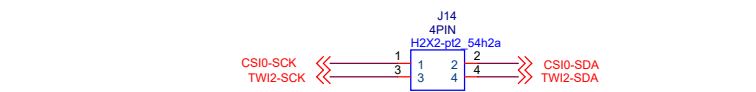
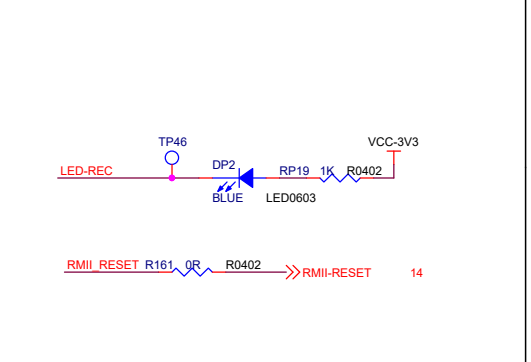
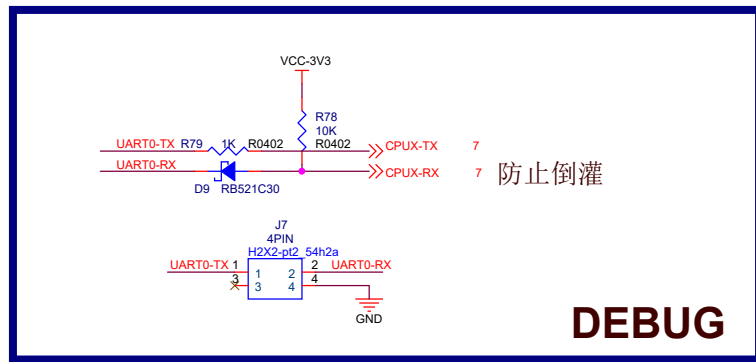
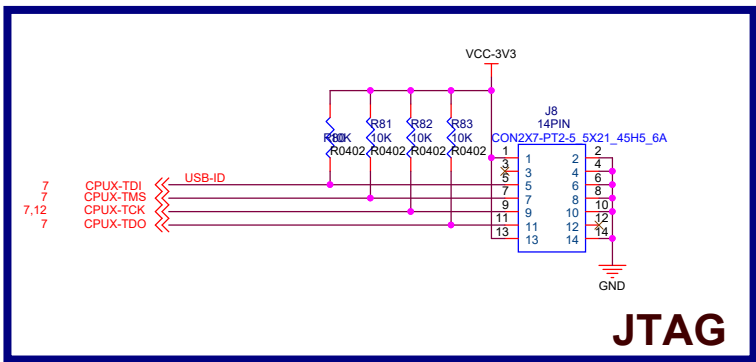
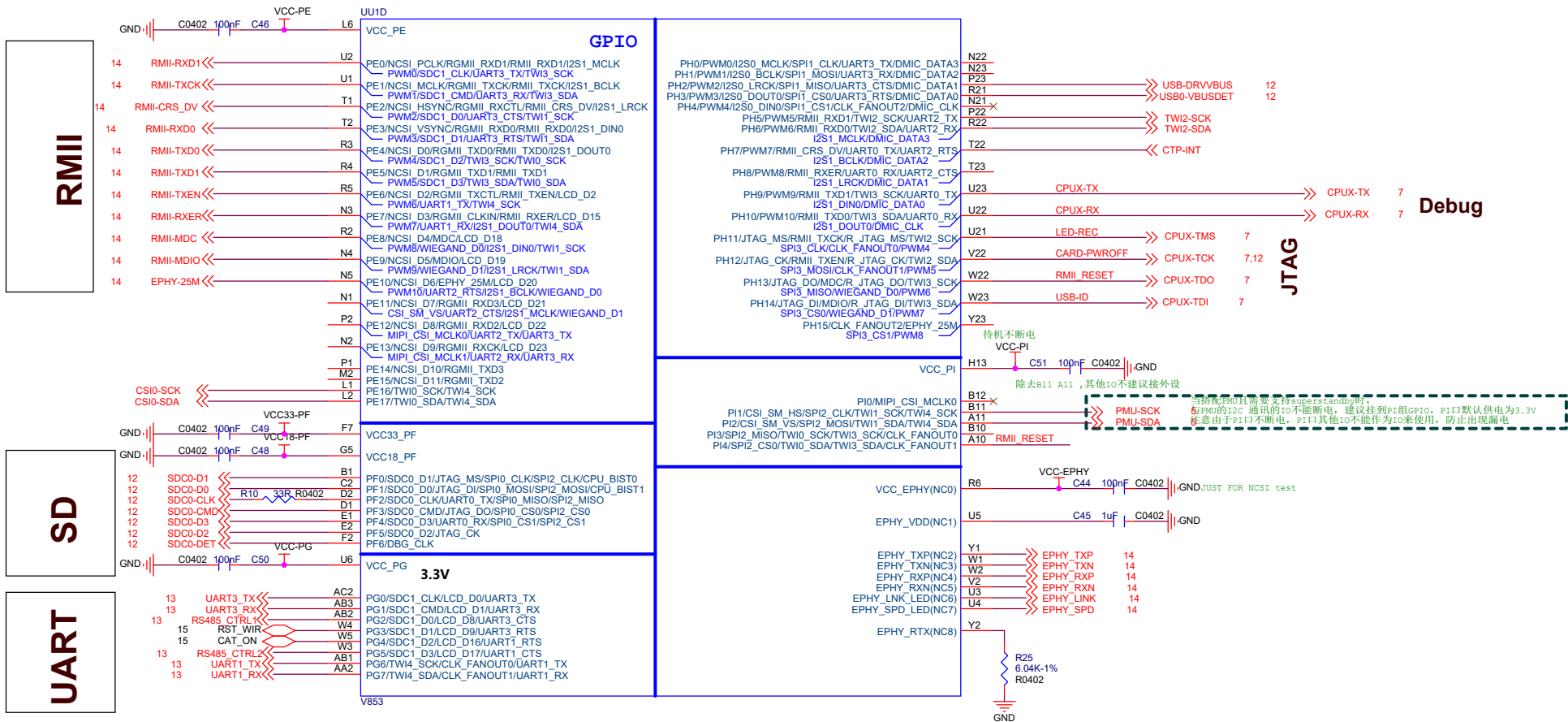

Project Name		<b>V853 PRO</b>	
Design Name		<b>JTAG/DEBUG</b>	
Size	ERP Code		
A3			
Date:	Friday, December 02, 2022	Sheet	7 of 15
Rev		V1.0	

# DDR3 16X1

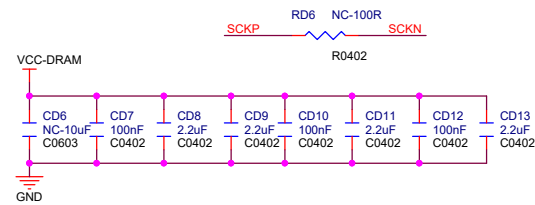
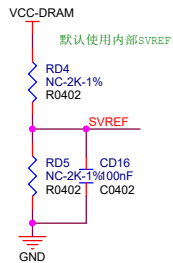
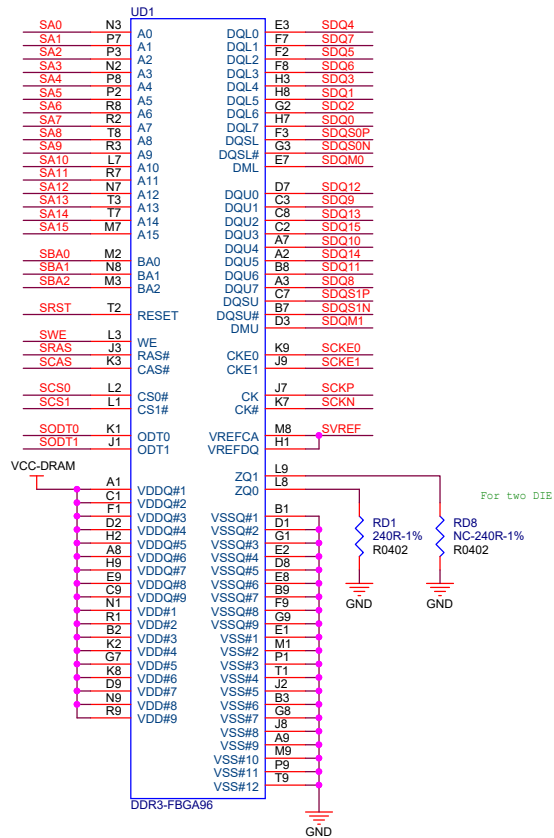
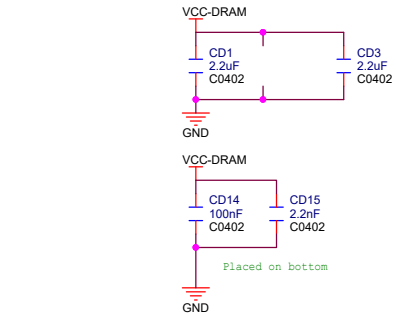
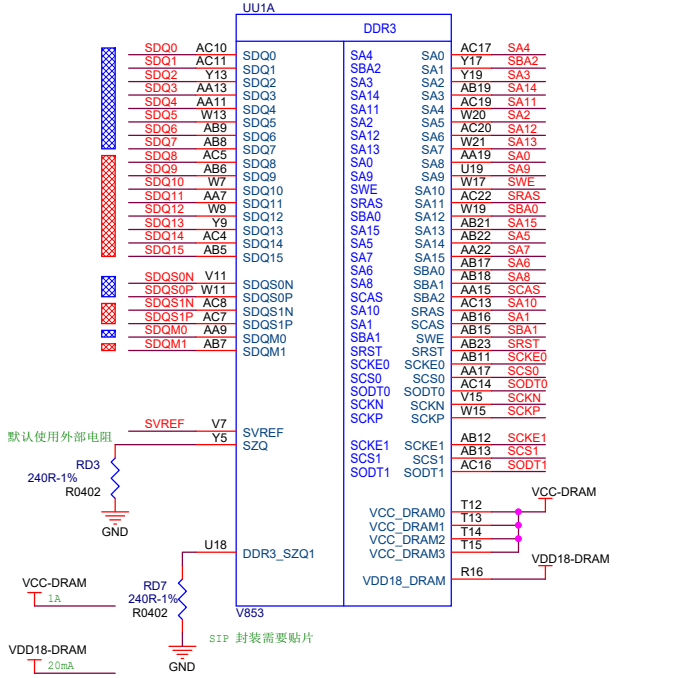



# FLASH

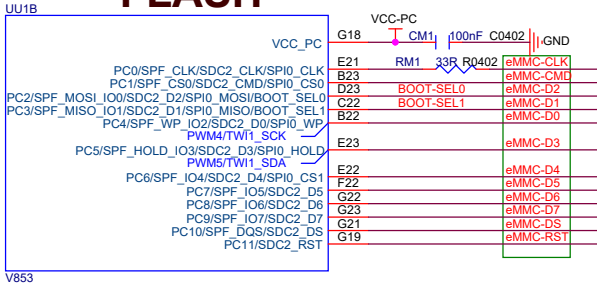

## BOOT-SEL

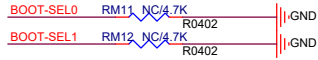

电阻靠近信号分叉点放置，以免影响信号质量

```
boot_sel[1:0]
0 0 SPI_NAND->SPI_NOR(4线)->SPI_NOR(1线)->USB
0 1 SPI_NOR(4线)->SPI_NOR(1线)->SPI_NAND->USB (快起)
1 0 SDC0->SPI_NAND->SPI_NOR(4线)->SPI_NOR(1线)->UART BRUN->USB
1 1 (默认) SDC0->SPI_NOR(4线)->SPI_NOR(1线)->EMMC2_USR->EMMC2_BOOT->
SPI0 NAND->UART BRUN->USB
```

# eMMC

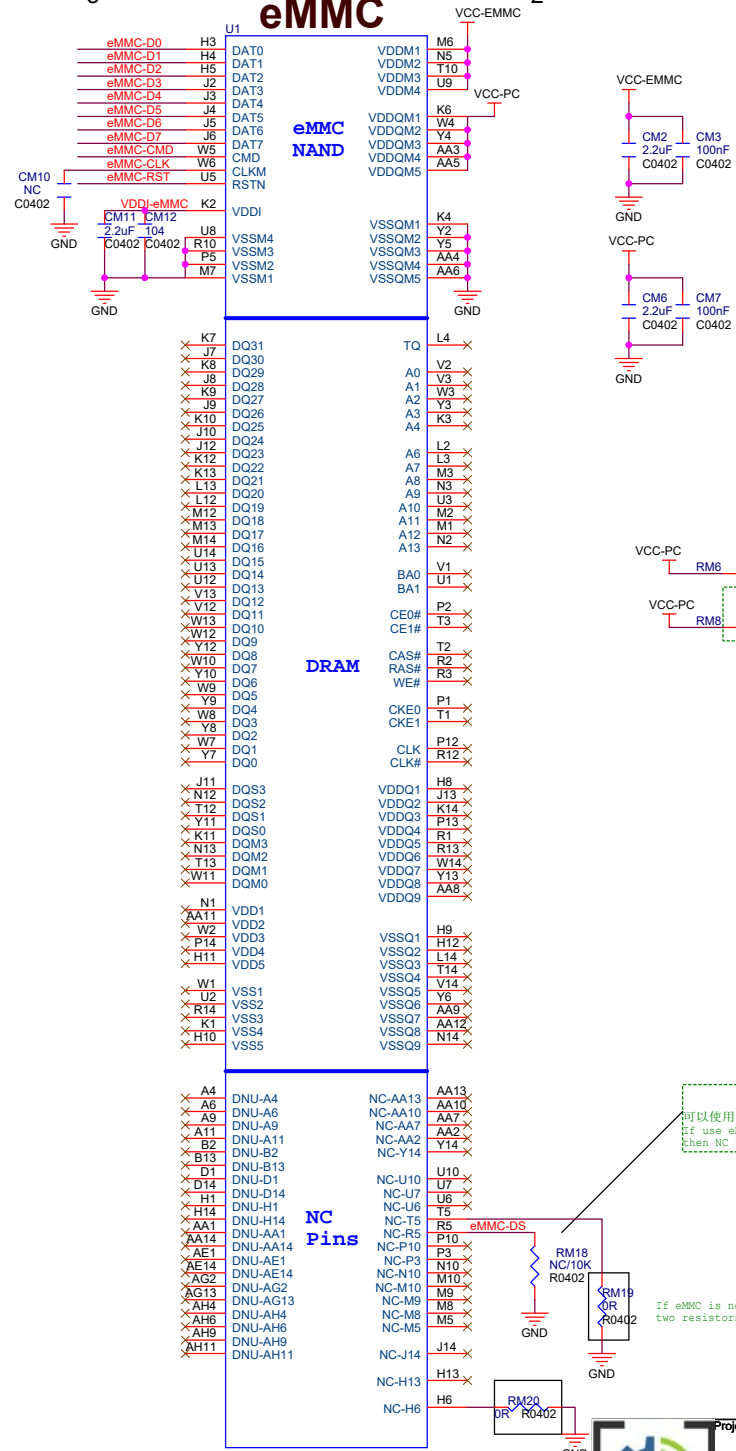

可以使用内部15k下拉，外部下拉默认NC  
If use eMMC is not v5.0/v5.1,  
then NC this resistor.

If eMMC is not v5.0/v5.1, then NC this  
two resistors.

Project Name: **V853 PRO**

Design Name: **BootLoader**

Size: A3 ERP Code: \_\_\_\_\_

Date: Friday, December 02, 2022 Sheet 9 of 15

Rev V1.0

# LCD/PWM

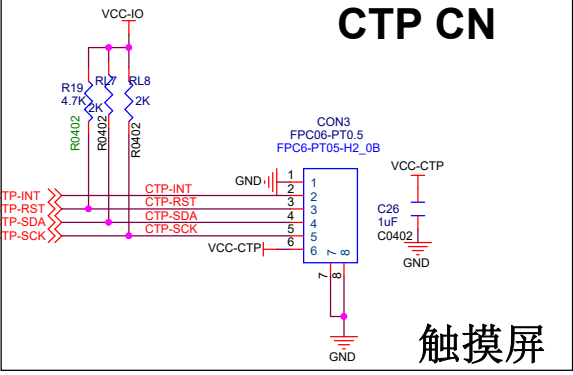
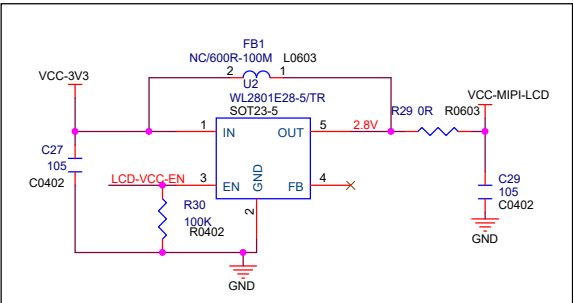
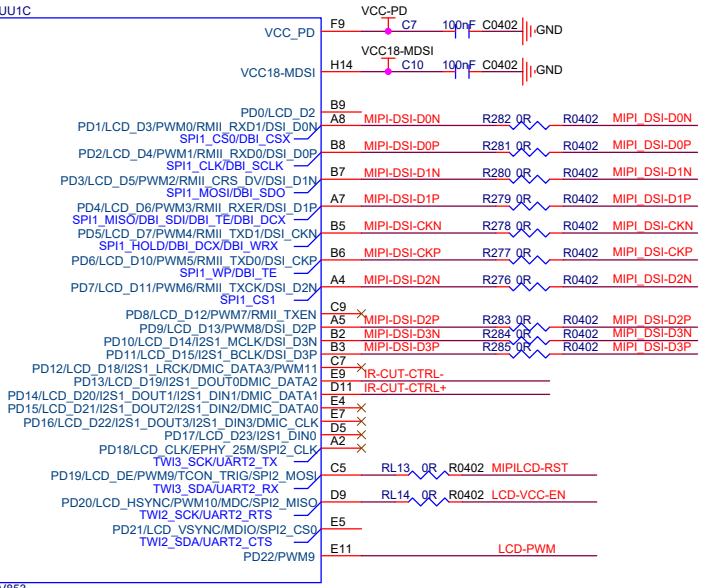

触摸屏

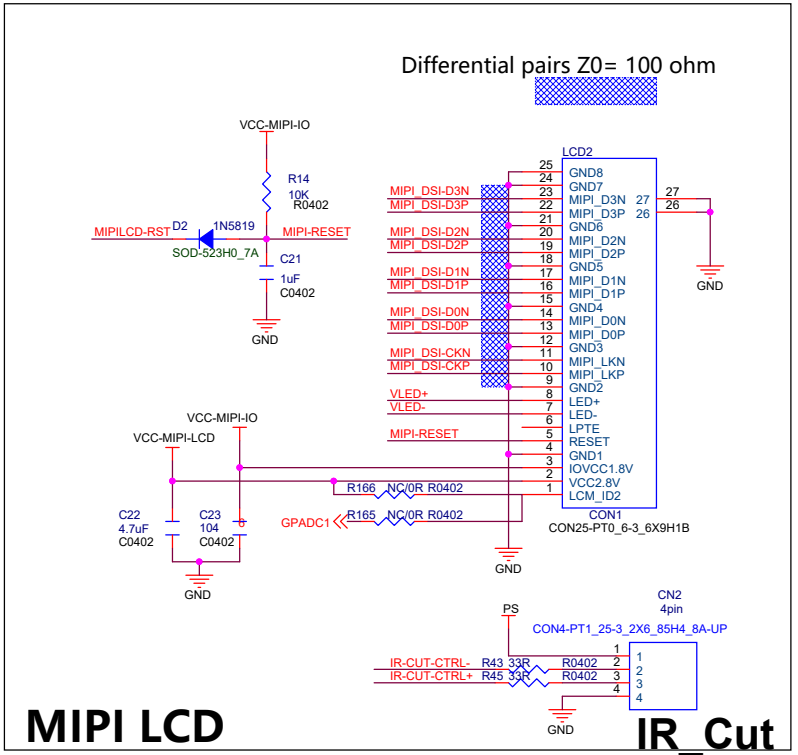

MIPI LCD

IR\_Cut

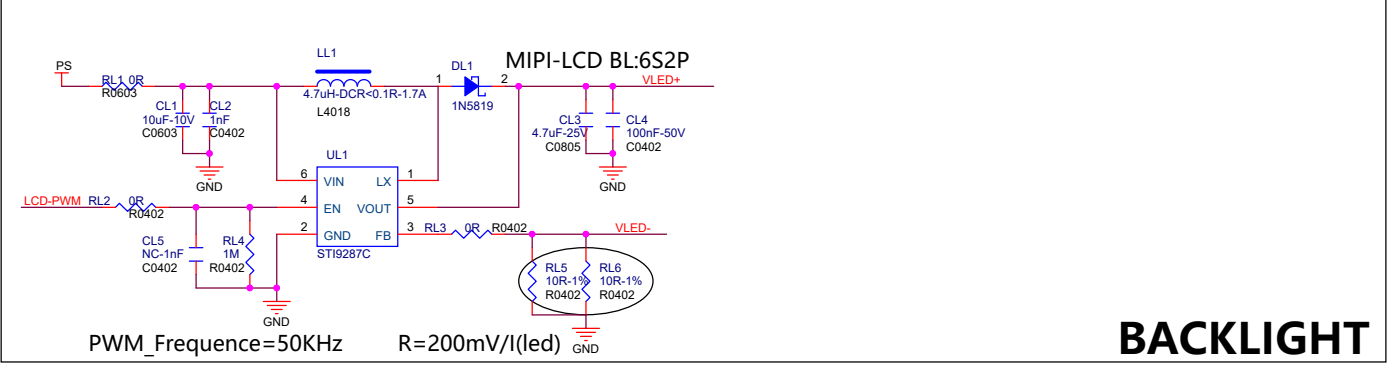

PWM\_Frequency=50KHz

R=200mV/I(led)

BACKLIGHT

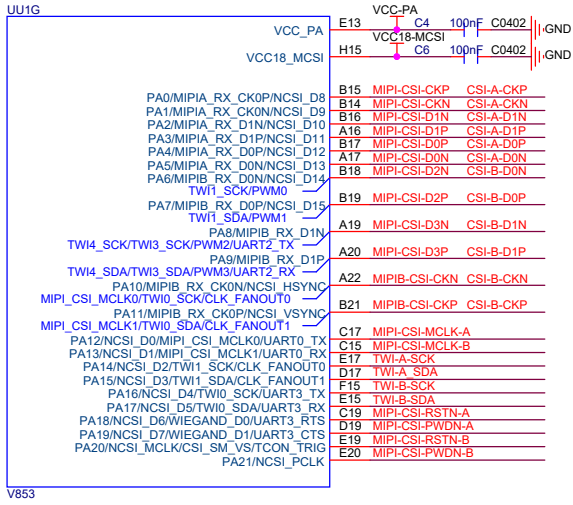

# MIPI CSI

IO	两组MIPI-2lane	MIPI-4lane
PA0	MIPIA-CST-CK0P	MIPI-CST-CKP
PA1	MIPIA-CST-CK0N	MIPI-CST-CKN
PA2	MIPIA-CST-D1N	MIPI-CST-D1N
PA3	MIPIA-CST-D1P	MIPI-CST-D1P
PA4	MIPIA-CST-D0P	MIPI-CST-D0P
PA5	MIPIA-CST-D0N	MIPI-CST-D0N
PA6	MIPIB-CST-D0N	MIPI-CST-D2N
PA7	MIPIB-CST-D0P	MIPI-CST-D2P
PA8	MIPIB-CST-D1N	MIPI-CST-D3N
PA9	MIPIB-CST-D1P	MIPI-CST-D3P
PA10	MIPIB-CST-CK0N	
PA11	MIPIB-CST-CK0P	

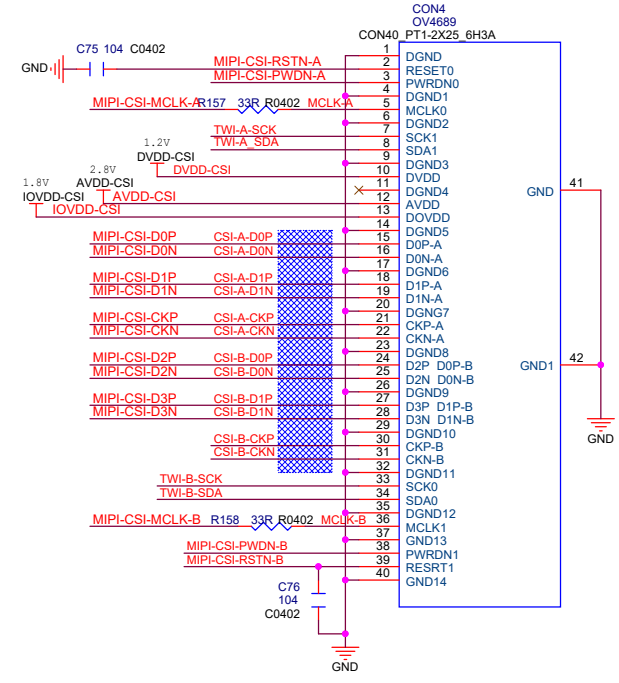
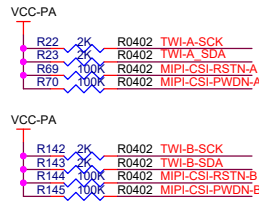

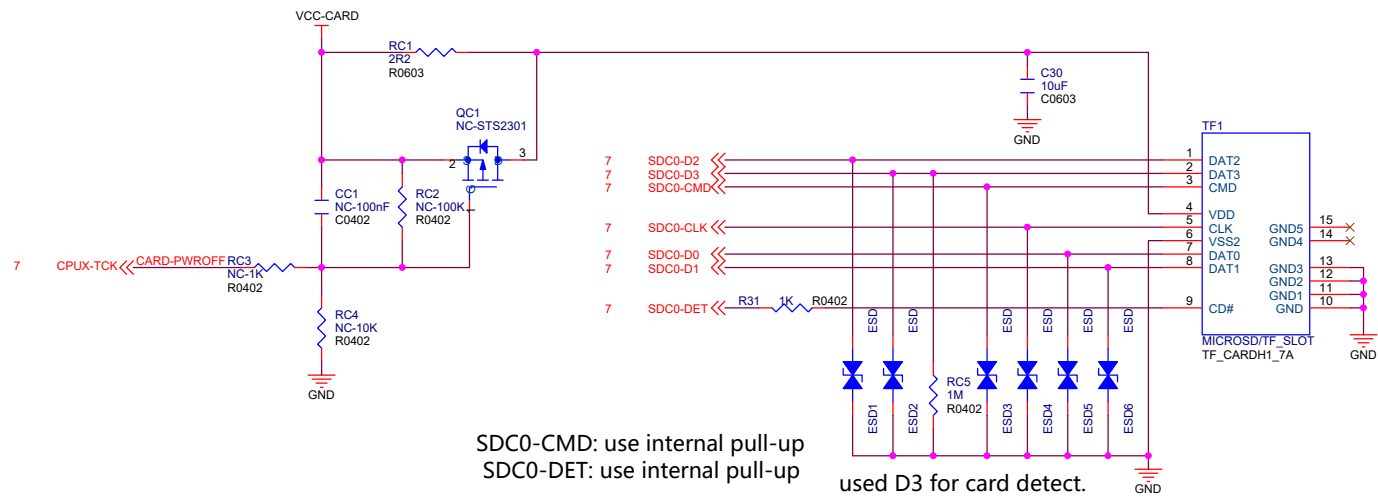

SDC0-CMD: use internal pull-up  
SDC0-DET: use internal pull-up

used D3 for card detect.

### TF CARD

### USB\_SWITCH

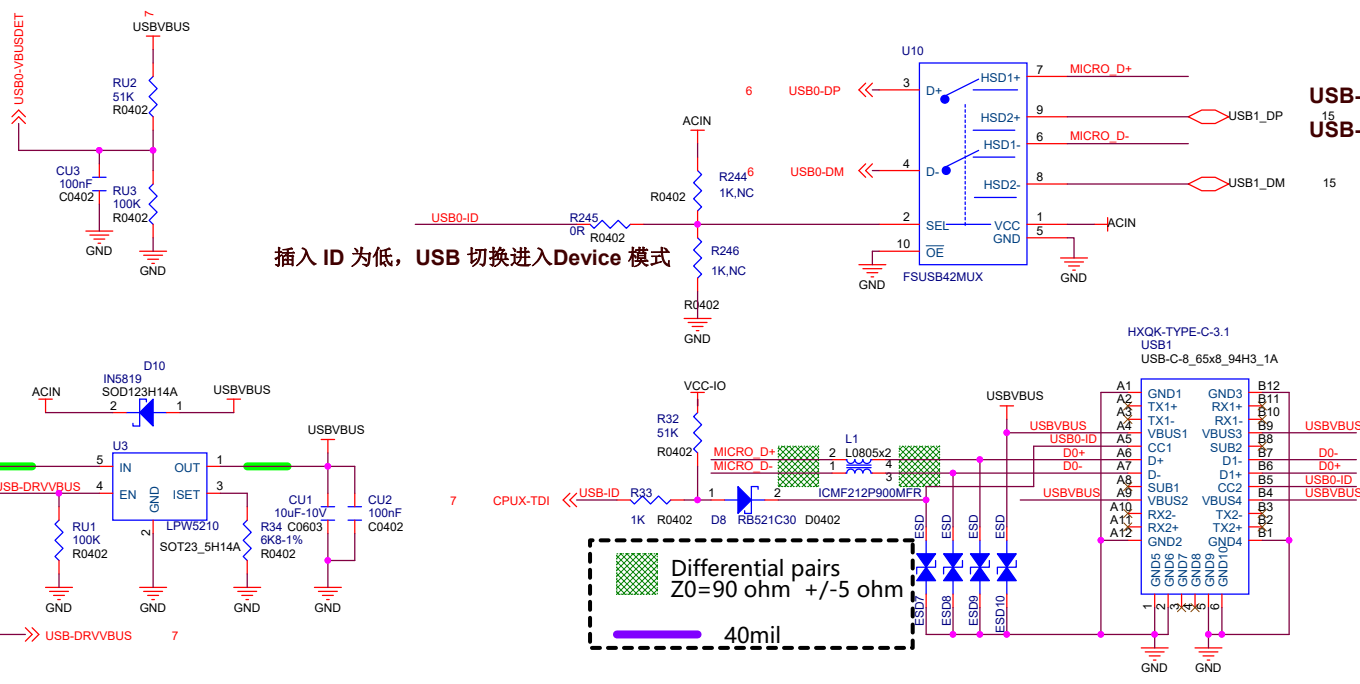

插入 ID 为低，USB 切换进入Device 模式

USB-ID:0 MICRO USB  
USB-ID:1 CAT1

Differential pairs  
Z0=90 ohm +/- 5 ohm  
40mil

### micro USB

# interface

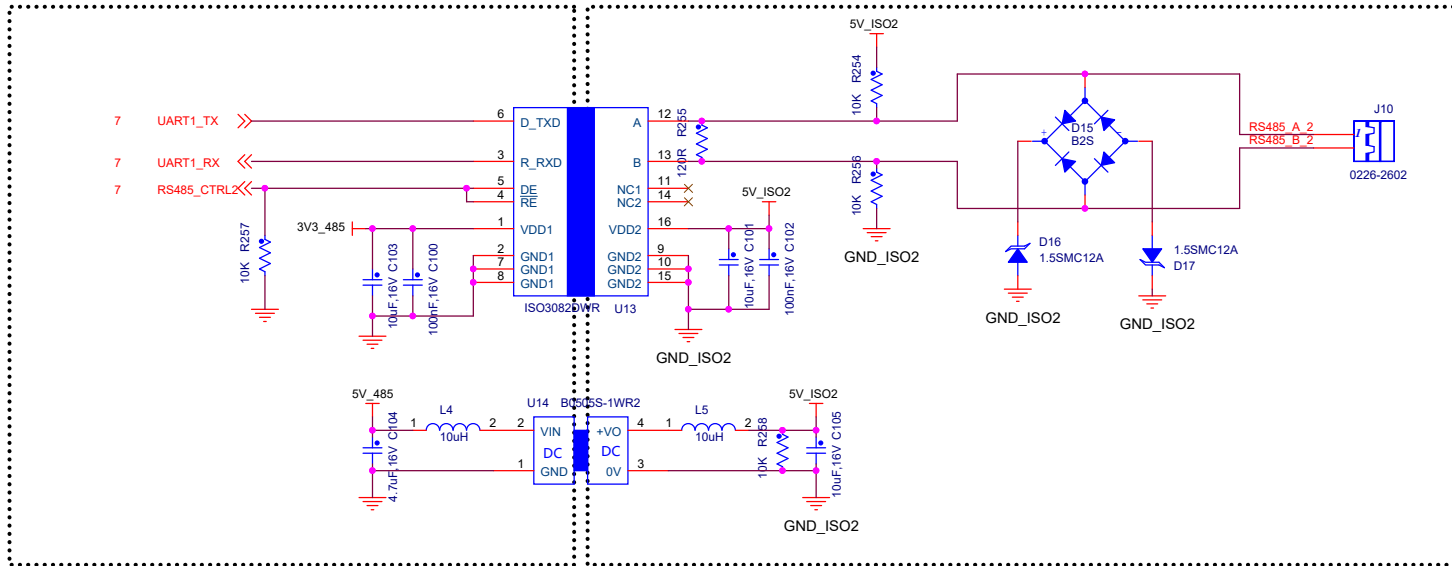
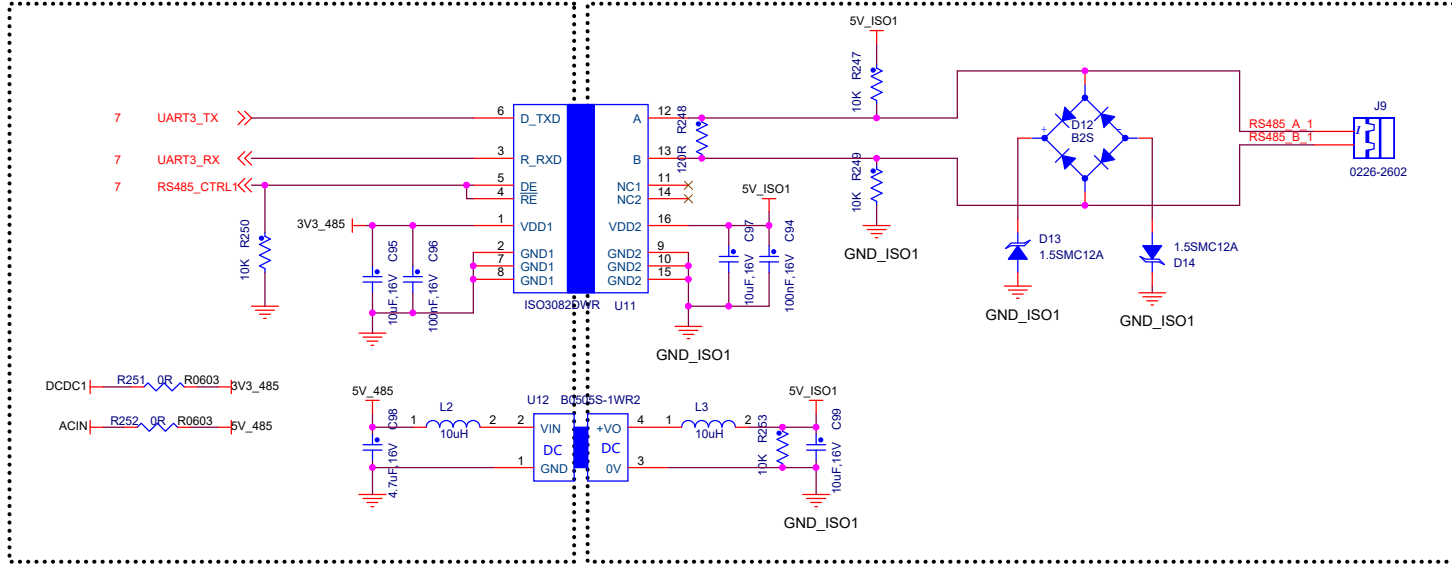

Project Name		<b>V853 PRO</b>	
Design Name		<b>rs485_ISO</b>	
Size	ERP Code	Rev	
A3		V1.0	
Date:	Friday, December 02, 2022	Sheet	13 of 15

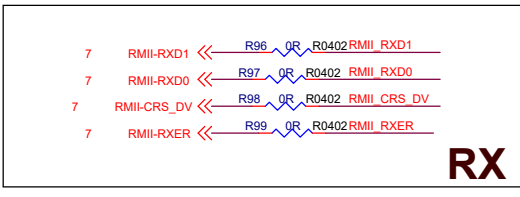
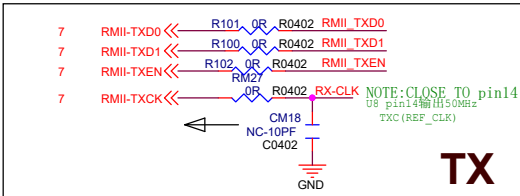
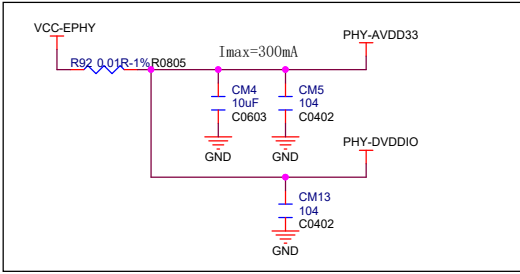

# RMII

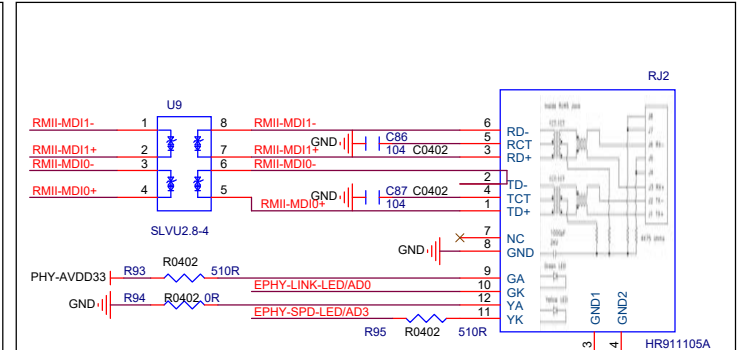
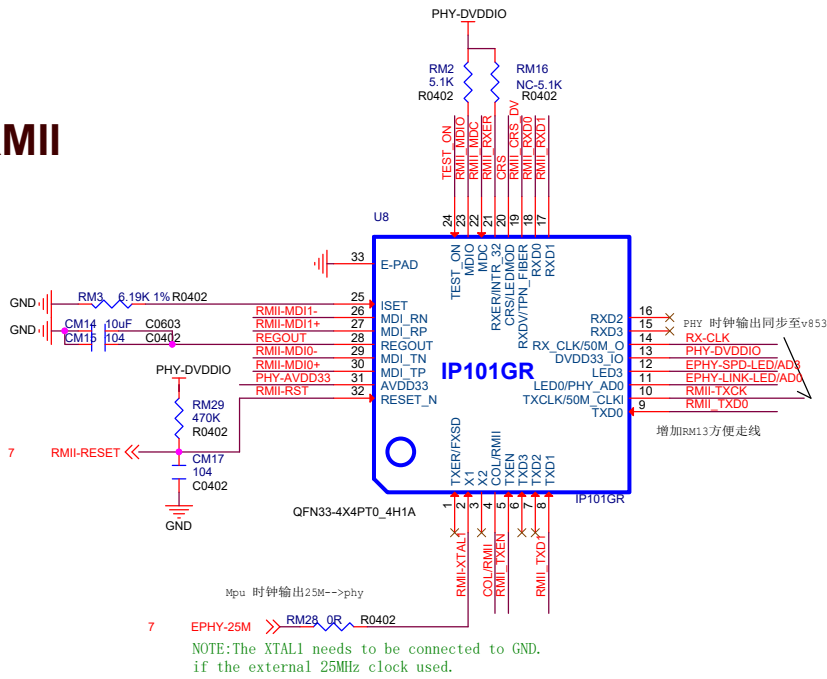

# phy address

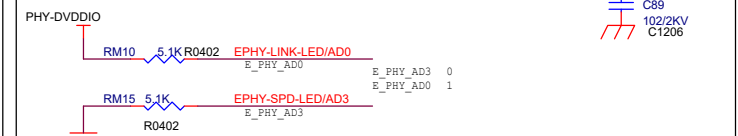

# CONFIG

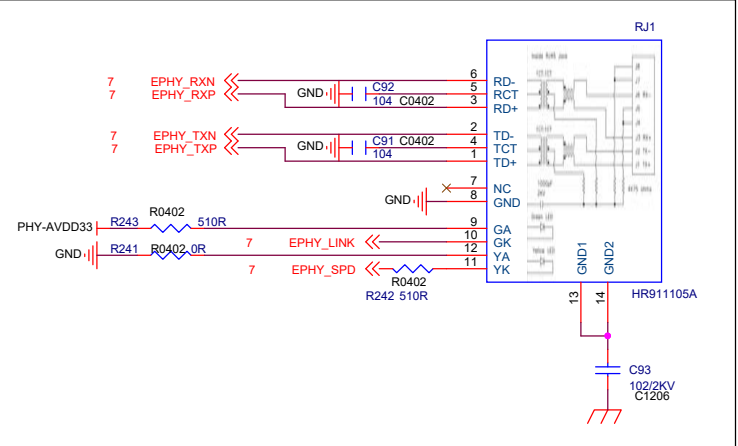
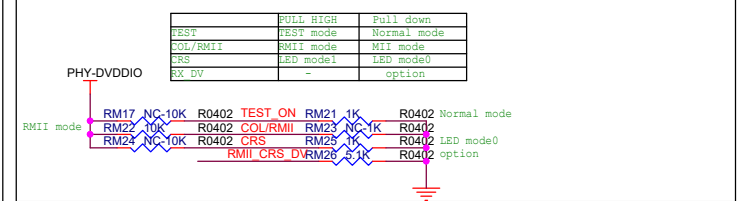

# Ephy

Project Name: **V853 PRO**

Design Name: **RMII**

Size: A3 ERP Code: \_\_\_\_\_

Date: Friday, December 02, 2022 Sheet: 14 of 15

Rev: V1.0

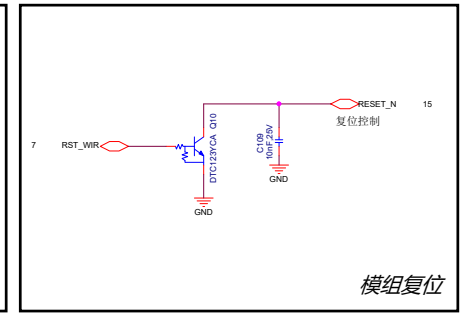
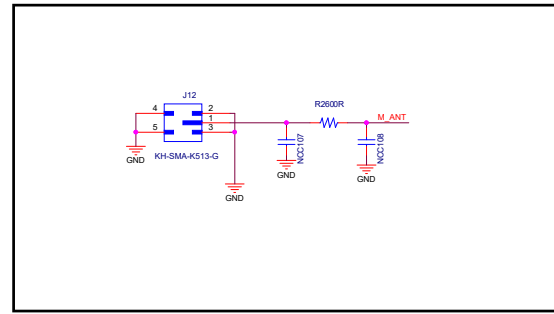
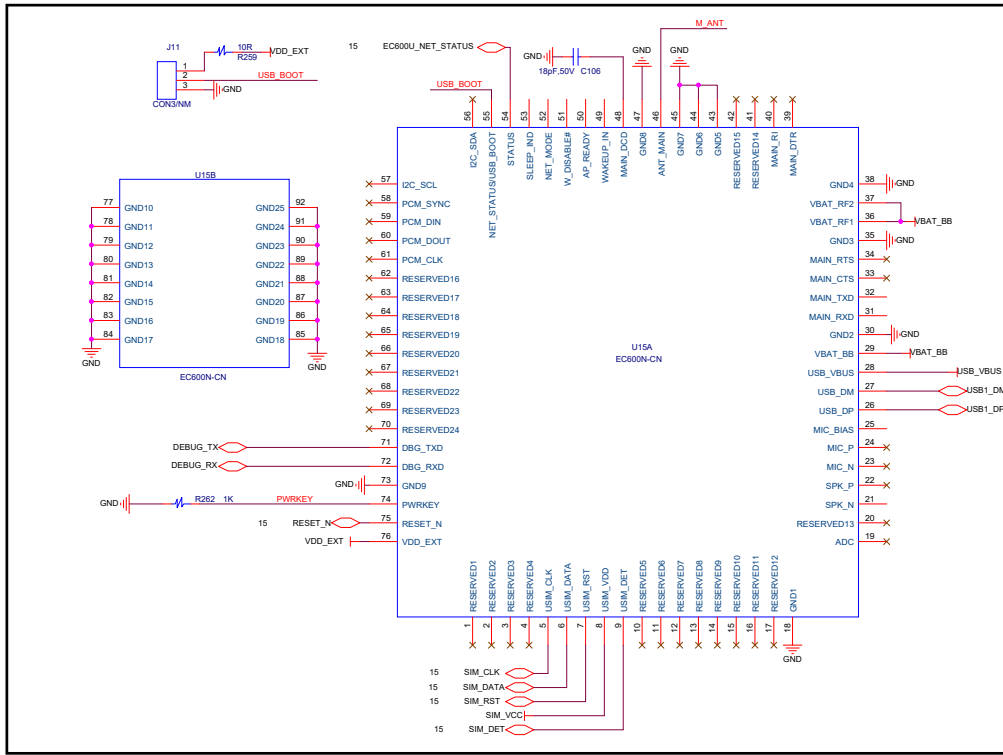

复位控制

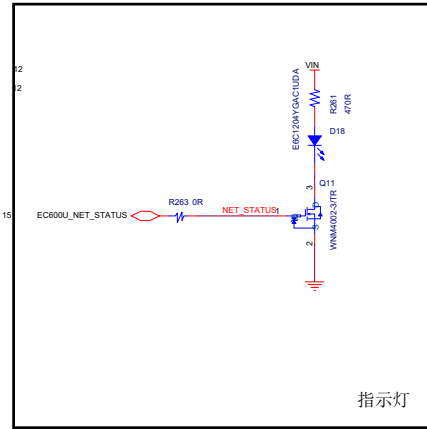

指示灯

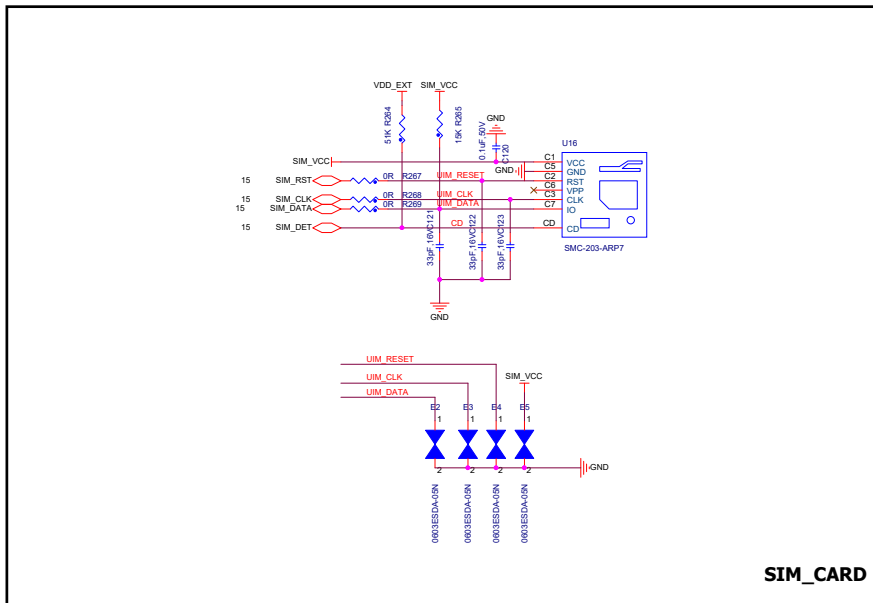
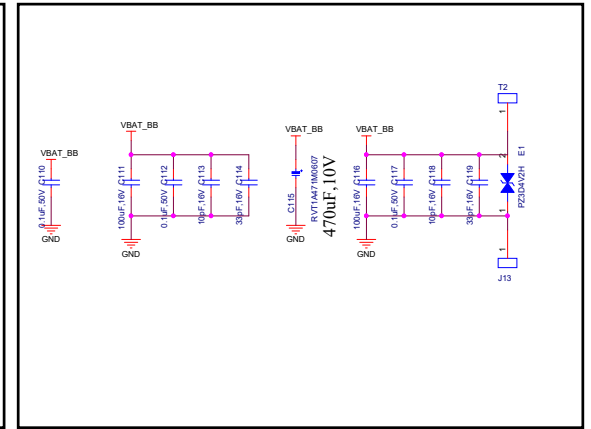

SIM\_CARD

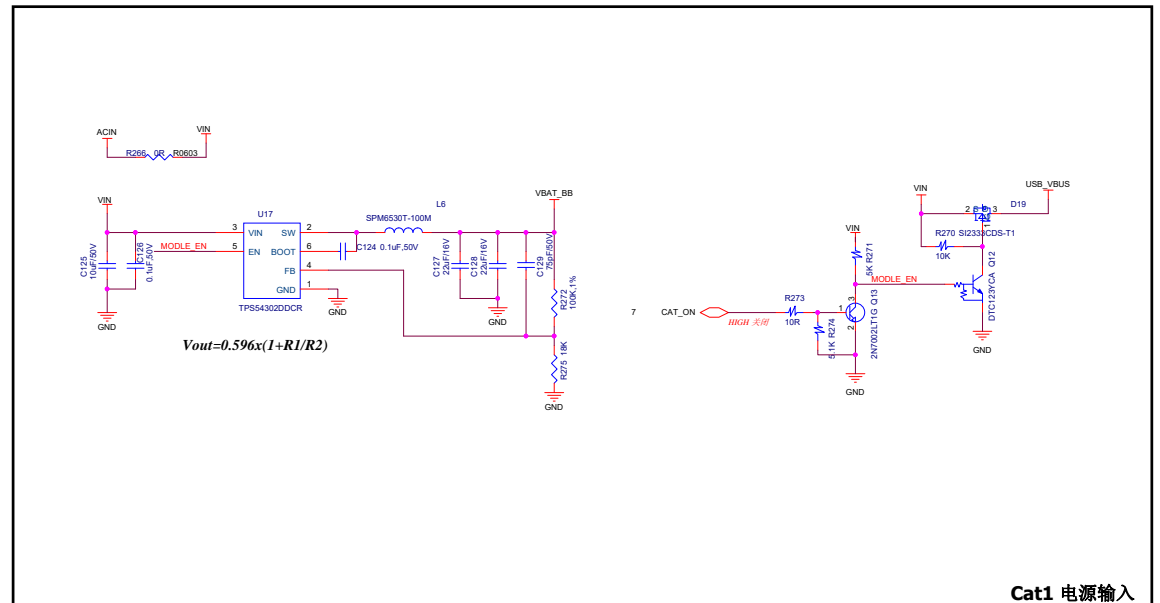

Cat1 电源输入