

Dec.1.2022 Copyright 2022 HIROSE ELECTRIC CO., LTD. All Rights Reserved.  
 In case of consideration for using Automotive equipment / device which demand high reliability, kindly contact our sales window correspondents.

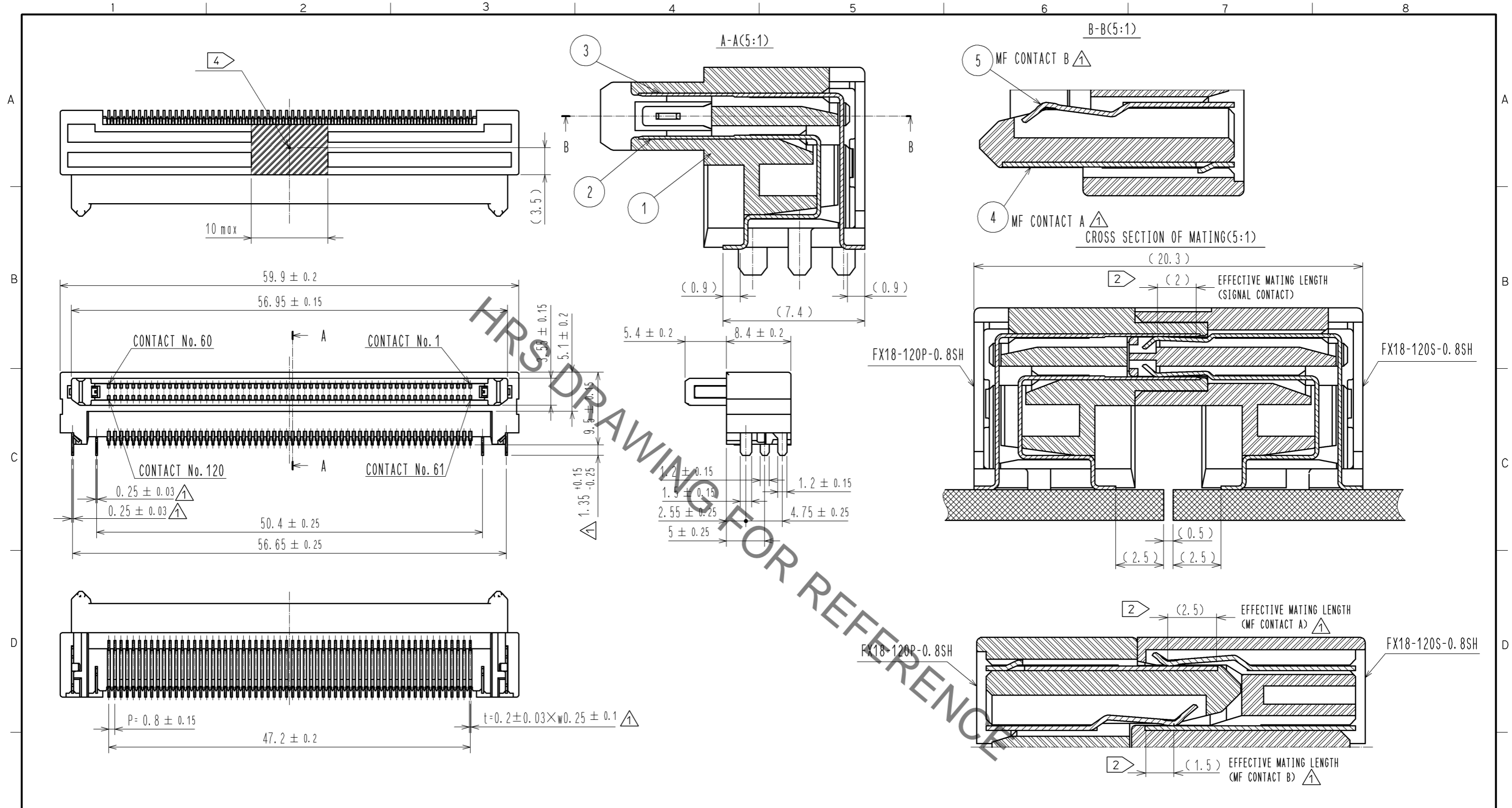

NOTE 1 LEAD CO-PLANARITY IS 0.1mm MAX.  
 ⚠️ ② CONTACTS ARE 3 STEPS SEQUENTIAL. (MF CONTACT A->SIGNAL CONTACT->MF CONTACT B) WHEN USING THIS SEQUENTIAL STRUCTURE. PLEASE AVOID ANGLED INSERTION.  
 ⚠️ ③ MF CONTACT A AND MF CONTACT B CAN BE USED AS POWER SUPPLY CONTACT. (3A/PIN MAX)  
 ④ IT SHOWS CONNECTOR'S CENTRE OF GRAVITY AND VACUUM PICKUP AREA.  
 ⑤ THIS IS PACKAGED IN TRAY. (40pcs/TRAY)  
 6 BLEMISH AND HIT MARK CAN BE OCCURED THROUGH OUT THE MANUFACTURING PROCESS WHICH DOESN' T AFFECT QUALITY LEVEL.  
 7 THE DIMENSIONS IN PARENTHESES ARE FOR REFERENCES.

NO.	MATERIAL	FINISH .	REMARKS	NO.	MATERIAL	FINISH .	REMARKS
3	PHOSPHOR BRONZE		CONTACT AREA:GOLD 0.1µm LEAD AREA:GOLD 0.03µm UNDER PLATING:NICKEL 1.3µm ⚠️	6	POLYSTYRENE		
2	PHOSPHOR BRONZE		CONTACT AREA:GOLD 0.1µm LEAD AREA:GOLD 0.03µm UNDER PLATING:NICKEL 1.3µm ⚠️	5	PHOSPHOR BRONZE		CONTACT AREA:GOLD 0.1µm LEAD AREA:TIN-PLATING 1µm UNDER PLATING:NICKEL 1.3µm ⚠️
1	POLYAMIDE	BLACK	UL94V-0	4	PHOSPHOR BRONZE		CONTACT AREA:GOLD 0.1µm LEAD AREA:TIN-PLATING 1µm UNDER PLATING:NICKEL 1.3µm ⚠️

  

UNITS	SCALE	COUNT	DESCRIPTION OF REVISIONS	DESIGNED	CHECKED	DATE
mm	2 : 1	4	DIS-F-005578	TH. SANO	KI. HIROKAWA	11.07.21

APPROVED	CHECED	DESIGNED	DRAWN	DATE	DRAWING NO.	PART NO.	CODE NO.
HS. OKAWA	HS. OZAWA	KI. HIROKAWA	KI. HIROKAWA	09.04.24	EDC3-159078-00	FX18-120P-0.8SH	CL579-0006-6-00

Dec.1.2022 Copyright 2022 HIROSE ELECTRIC CO., LTD. All Rights Reserved.  
 In case of consideration for using Automotive equipment / device which demand high reliability, kindly contact our sales window correspondents.

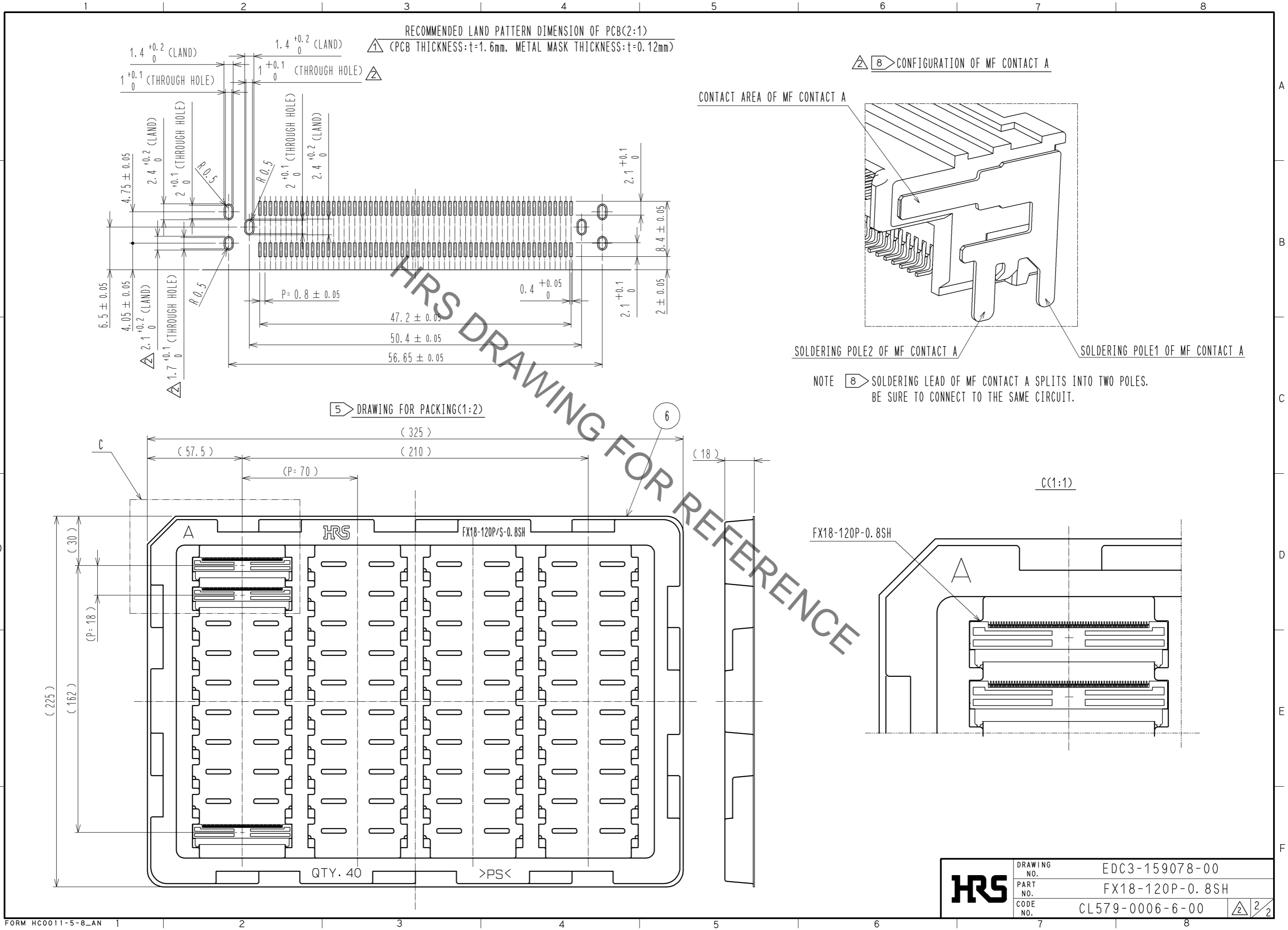

<b>HRS</b>	DRAWING NO.	EDC3-159078-00	2/2
	PART NO.	FX18-120P-0.8SH	
	CODE NO.	CL579-0006-6-00	