

SECTION Z-Z

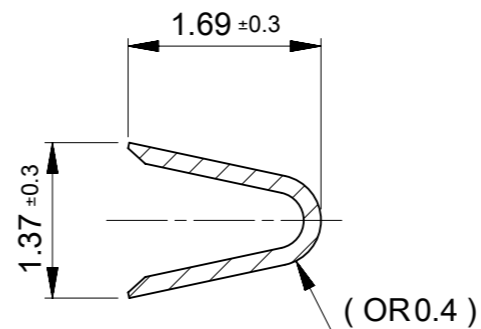

SECTION Y-Y

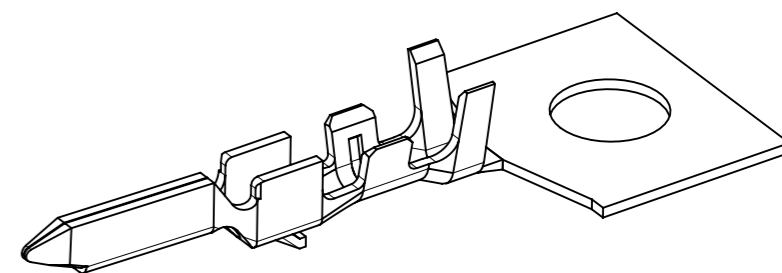

NOTE

- 1 材料及び仕上げ(めっき仕様) : TABLE 1 参照
MATERIAL AND FINISHES : SEE TABLE 1
- 2 適合製品および各種仕様書についてはSHEET 2 を参照。
PLEASE REFER TO SHEET 2 FOR APPLICABLE PRODUCTS AND SPECIFICATIONS.

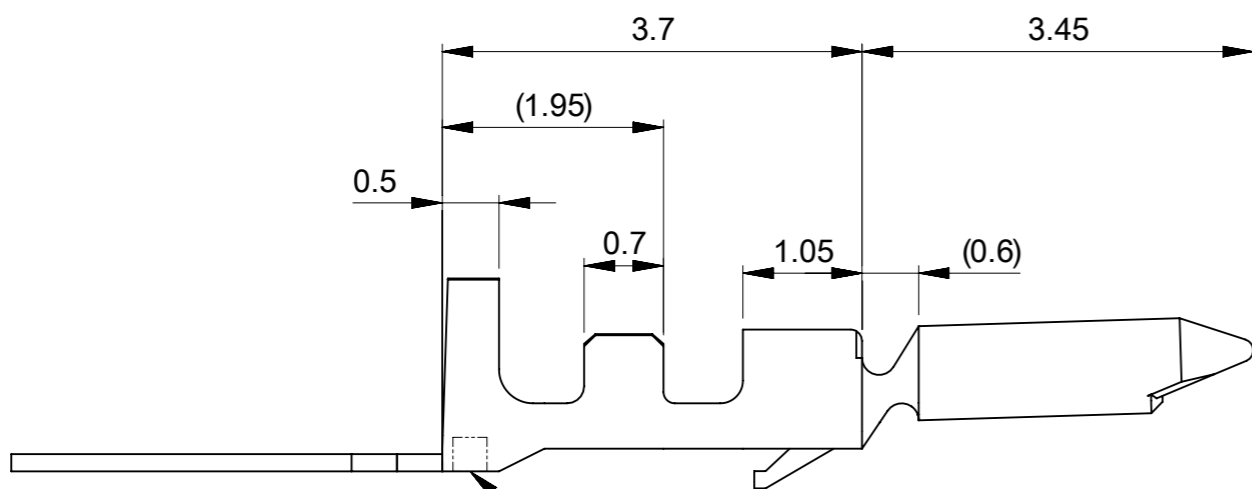

トレードマーク
TRADE MARK

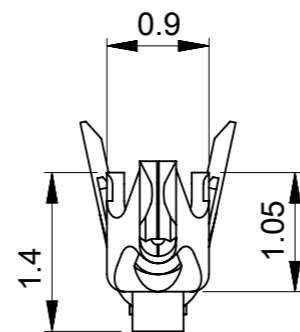

1 **TABLE 1**

部品 PART	材質 MATERIAL
ターミナル TERMINAL	りん青銅 PHOSPHOR BRONZE 錫めっき 0.9 MICROMETER MINIMUM (リフロー処理、前めっき) TIN PLATING 0.9 MICROMETER MINIMUM (REFLOW TREATMENT, PRE-PLATED)

DOCUMENT STATUS	P1	RELEASE DATE	2022/04/19	08:41:19
-----------------	----	--------------	------------	----------

Φ0.5-Φ1.0	AWG#28-32	ポリ袋 POLYBAG	バラ状 LOOSE	501338100
		リール REEL	連鎖状 CHAIN	501338000
被覆外径 INSULATION RANGE	適用電線範囲 WIRE RANGE	梱包形態 PACKING	端子形状 FORM	オーダー番号 ORDER NO

THIS DRAWING CONTAINS INFORMATION THAT IS PROPRIETARY TO MOLEX ELECTRONIC TECHNOLOGIES, LLC AND SHOULD NOT BE USED WITHOUT WRITTEN PERMISSION

DIMENSION UNITS	SCALE	CURRENT REV DESC: REVISED		
mm	NTS	molex		
GENERAL TOLERANCES (UNLESS SPECIFIED)				
ANGULAR TOL	± 3.0 °	PICOBLADE 1.25 PLUG CRIMP TERMINAL TIN PLATING AWG28-32		
4 PLACES	± 0.2	PRODUCT CUSTOMER DRAWING		
3 PLACES	± 0.2	DOCUMENT NUMBER		
2 PLACES	± 0.2	501330000-SD		
1 PLACE	± 0.2	DOC TYPE		
0 PLACES	± 0.2	PSD		
DRAFT WHERE APPLICABLE MUST REMAIN WITHIN DIMENSIONS		THIRD ANGLE PROJECTION		DOC PART
		DRAWING		000
		SERIES		B
		MATERIAL NUMBER		REVISION
		A3-SIZE		
		50133		
		CUSTOMER		
		SEE CHART		
		SHEET NUMBER		
		1 OF 2		

△₂ 適合製品および各種仕様書
 APPLICABLE PRODUCTS AND SPECIFICATIONS

梱包仕様書 PACKING SPECIFICATION		PART NUMBER 501338*00		SPECIFICATION NUMBER 501339200-SPK 200	
適合ハウジング APPLICABLE HOUSING		PART NUMBER 51047**00			
適合嵌合相手 MATE WITH		PART NUMBER 51021**00			
適合圧着端子 APPLICABLE TERMINAL	PLATING TYPE	TIN			
	PART NUMBER	500798*00	500588*00	500798001	500588001
	WIRE SIZE (AWG)	#26-28	#28-32	#26-28	#28-32
製品仕様書 PRODUCT SPECIFICATION		PS-51021-009 PS 001		510211109-PS PS 000	
アプリケーション仕様書 (取扱説明書) APPLICATION SPECIFICATION		510210001-AS PS 000			

製品嵌合図は各"適合嵌合相手"図面参照のこと
 MATING VIEW: REFER TO EACH "MATE WITH" PART DRAWING.

THIS DRAWING CONTAINS INFORMATION THAT IS PROPRIETARY TO MOLEX ELECTRONIC TECHNOLOGIES, LLC AND SHOULD NOT BE USED WITHOUT WRITTEN PERMISSION									
DIMENSION UNITS	SCALE	CURRENT REV DESC: REVISED					molex		
mm	NTS								
GENERAL TOLERANCES (UNLESS SPECIFIED)							PICOBLADE 1.25 PLUG CRIMP TERMINAL TIN PLATING AWG28-32		
ANGULAR TOL	± 3.0 °						PRODUCT CUSTOMER DRAWING		
4 PLACES	± 0.2	EC NO: 698818							
3 PLACES	± 0.2	DRWN: HHUSSIN			2022/02/16				
2 PLACES	± 0.2	CHK'D: SAKIYAMA			2022/04/19				
1 PLACE	± 0.2	APPR: AIDA			2022/04/19				
0 PLACES	± 0.2	INITIAL REVISION:							
DRAFT WHERE APPLICABLE MUST REMAIN WITHIN DIMENSIONS		DRWN: QHE31			2021/12/15	DOCUMENT NUMBER	DOC TYPE	DOC PART	REVISION
		APPR: KOMURAKAMI			2021/12/24	501330000-SD	PSD	000	B
		THIRD ANGLE PROJECTION	DRAWING	SERIES	MATERIAL NUMBER	CUSTOMER		SHEET NUMBER	
			A3-SIZE	50133	SEE CHART			2 OF 2	