

Qi Compliant Wireless Power Transmitter Manager

 Check for Samples: [bq500210](#)

FEATURES

- **Intelligent Control of the Power Transfer between Base Station and Mobile Device**
- **Conforms to the Wireless Power Consortium (WPC) Wireless Power Transfer 1.0.2 Specification**
- **Digital Demodulation Significantly Simplifies Solution Over bq500110**
- **Improved Parasitic Metal Object Detection (PMOD) Promotes Safety During Wireless Power Transfer**
- **Enhanced Charge Status Indicator**
- **Operating Modes Status Indicators**
 - Standby
 - Power Transfer (visual and audio)
 - Charge Complete
 - Fault
- **Over Temperature Protection**

APPLICATIONS

- **WPC 1.0.2 Compliant Wireless Chargers for:**
 - Mobile and Smart Phones
 - MP3 Players
 - Global Positioning Devices
 - Digital Cameras
- **Other Wireless Power Transmitters in:**
 - Cars and Other Vehicles
 - Hermetically Sealed Devices, Tools, and Appliances
 - Furniture Built-In Wireless Chargers
 - Toy Power Supplies and Chargers
- See www.ti.com/wirelesspower for More Information on TI's Wireless Charging Solutions

DESCRIPTION

The bq500210 is a second generation Wireless Power dedicated digital controller that integrates the logic functions required to control Wireless Power Transfer in a single channel WPC compliant contactless charging base station. The bq500210 is an intelligent device that periodically pings the surrounding environment for available devices to be powered, monitors all communication from the device being wirelessly powered, and adjusts power applied to the transmitter coil per feedback received from the powered device. The bq500210 also manages the fault conditions associated with the power transfer and controls the operating modes status indicator. The bq500210 supports improved Parasitic Metal Object Detection (PMOD). The controller in real time analyzes the efficiency of the established power transfer using Rectified Power Packets and protects itself and the power receiver from excessive power loss and heat associated with parasitic metal objects placed in the power transfer path.

The bq500210 is available in an area saving 48-pin, 7mm x 7mm QFN package and operates over a temperature range from -40°C to 110°C .

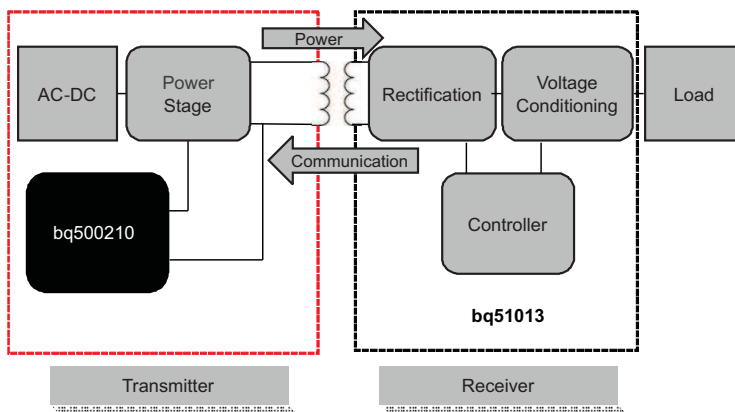

Please be aware that an important notice concerning availability, standard warranty, and use in critical applications of Texas Instruments semiconductor products and disclaimers thereto appears at the end of this data sheet.



These devices have limited built-in ESD protection. The leads should be shorted together or the device placed in conductive foam during storage or handling to prevent electrostatic damage to the MOS gates.

ORDERING INFORMATION⁽¹⁾

| OPERATING TEMPERATURE RANGE, T _A | ORDERABLE PART NUMBER | PIN COUNT | SUPPLY | PACKAGE | TOP SIDE MARKING |
|---|-----------------------|-----------|--------------|---------|------------------|
| -40°C to 110°C | bq500210RGZR | 48 pin | Reel of 2500 | QFN | bq500210 |
| | bq500210RGZT | 48 pin | Reel of 250 | QFN | bq500210 |

- (1) For the most current package and ordering information, see the Package Option Addendum at the end of this document, or see the TI web site at www.ti.com.

ABSOLUTE MAXIMUM RATINGS⁽¹⁾

over operating free-air temperature range (unless otherwise noted)

| | VALUE | | UNIT |
|---|-------|-----|------|
| | MIN | MAX | |
| Voltage applied at V33D to DGND | -0.3 | 3.8 | V |
| Voltage applied at V33A to AGND | -0.3 | 3.8 | V |
| Voltage applied to any pin ⁽²⁾ | -0.3 | 3.8 | V |
| Storage temperature, T _{STG} | -40 | 150 | °C |

- (1) Stresses beyond those listed under *absolute maximum ratings* may cause permanent damage to the device. These are stress ratings only and functional operation of the device at these or any other conditions beyond those indicated under *recommended operating conditions* is not implied. Exposure to absolute-maximum-rated conditions for extended periods may affect device reliability.
- (2) All voltages referenced to GND.

THERMAL INFORMATION

| THERMAL METRIC ⁽¹⁾ | | bq500210 | UNITS |
|-------------------------------|---|----------|-------|
| | | RGZ | |
| | | 48 PINS | |
| θ_{JA} | Junction-to-ambient thermal resistance ⁽²⁾ | 28.4 | °C/W |
| $\theta_{JC(top)}$ | Junction-to-case(top) thermal resistance ⁽³⁾ | 13.9 | |
| θ_{JB} | Junction-to-board thermal resistance ⁽⁴⁾ | 5.3 | |
| ψ_{JT} | Junction-to-top characterization parameter ⁽⁵⁾ | 0.2 | |
| ψ_{JB} | Junction-to-board characterization parameter ⁽⁶⁾ | 5.2 | |
| $\theta_{JC(bottom)}$ | Junction-to-case(bottom) thermal resistance ⁽⁷⁾ | 1.4 | |

- (1) For more information about traditional and new thermal metrics, see the *IC Package Thermal Metrics* application report, [SPRA953](#).
- (2) The junction-to-ambient thermal resistance under natural convection is obtained in a simulation on a JEDEC-standard, high-K board, as specified in JESD51-7, in an environment described in JESD51-2a.
- (3) The junction-to-case (top) thermal resistance is obtained by simulating a cold plate test on the package top. No specific JEDEC-standard test exists, but a close description can be found in the ANSI SEMI standard G30-88.
- (4) The junction-to-board thermal resistance is obtained by simulating in an environment with a ring cold plate fixture to control the PCB temperature, as described in JESD51-8.
- (5) The junction-to-top characterization parameter, ψ_{JT} , estimates the junction temperature of a device in a real system and is extracted from the simulation data for obtaining θ_{JA} , using a procedure described in JESD51-2a (sections 6 and 7).
- (6) The junction-to-board characterization parameter, ψ_{JB} , estimates the junction temperature of a device in a real system and is extracted from the simulation data for obtaining θ_{JA} , using a procedure described in JESD51-2a (sections 6 and 7).
- (7) The junction-to-case (bottom) thermal resistance is obtained by simulating a cold plate test on the exposed (power) pad. No specific JEDEC standard test exists, but a close description can be found in the ANSI SEMI standard G30-88.

RECOMMENDED OPERATING CONDITIONS

over operating free-air temperature range (unless otherwise noted)

| | | MIN | NOM | MAX | UNIT |
|----------------|---|-----|-----|-----|------|
| V | Supply voltage during operation, V33D, V33A | 3.0 | 3.3 | 3.6 | V |
| T _A | Operating free-air temperature range | -40 | | 125 | °C |
| T _J | Junction temperature | | | 125 | °C |

ELECTRICAL CHARACTERISTICS

over operating free-air temperature range (unless otherwise noted)

| PARAMETER | | TEST CONDITIONS | MIN | NOM | MAX | UNIT |
|--|--|---|-------|-------------|--------------|------|
| SUPPLY CURRENT | | | | | | |
| I _{V33A} | Supply current | V33A = 3.3 V | | 8 | 15 | mA |
| I _{V33D} | | V33D = 3.3 V | | 42 | 55 | |
| I _{V33D} | | V33D = 3.3 V while storing configuration parameters in flash memory | | 53 | 65 | |
| INTERNAL REGULATOR CONTROLLER INPUTS/OUTPUTS | | | | | | |
| V33 | 3.3-V linear regulator | Emitter of NPN transistor | 3.25 | 3.3 | 3.6 | V |
| V33FB | 3.3-V linear regulator feedback | | | 4 | 4.6 | |
| I _{V33FB} | Series pass base drive | V _{IN} = 12 V; current into V33FB pin | | 10 | | mA |
| Beta | Series NPN pass device | | 40 | | | |
| EXTERNALLY SUPPLIED 3.3 V POWER | | | | | | |
| V33D | Digital 3.3-V power | T _A = 25°C | 3 | | 3.6 | V |
| V33A | Analog 3.3-V power | T _A = 25°C | 3 | | 3.6 | |
| V33Slew | V33 slew rate | V33 slew rate between 2.3V and 2.9V, V33A = V33D | 0.25 | | | V/ms |
| MODULATION AMPLIFIER INPUTS EAP-A, EAN-A, EAP-B, EAN-B | | | | | | |
| V _{CM} | Common mode voltage each pin | | -0.15 | | 1.631 | V |
| EAP-EAN | Modulation voltage digital resolution | | | 1 | | |
| R _{EA} | Input Impedance | Ground reference | 0.5 | 1.5 | 3 | MΩ |
| I _{OFFSET} | Input offset current | 1 kΩ source impedance | -5 | | 5 | |
| ANALOG INPUTS V_IN, I_IN, TEMP_IN, I_COIL, LED_MODE, PMOD_THR | | | | | | |
| V _{ADDR_OPEN} | Voltage indicating open pin | LED_MODE, PMOD_THR open | 2.37 | | | V |
| V _{ADDR_SHORT} | Voltage indicating pin shorted to GND | LED_MODE, PMOD_THR shorted to ground | | | 0.36 | |
| V _{ADC_RANGE} | Measurement range for voltage monitoring | Inputs: V_IN, I_IN, TEMP_IN, I_COIL | 0 | | 2.5 | V |
| INL | ADC integral nonlinearity | | -2.5 | | 2.5 | |
| I _{lkg} | Input leakage current | 3V applied to pin | | | 100 | nA |
| R _{IN} | Input impedance | Ground reference | 8 | | | |
| C _{IN} | Input capacitance | | | | 10 | pF |
| DIGITAL INPUTS/OUTPUTS | | | | | | |
| V _{OL} | Low-level output voltage | I _{OL} = 6 mA ⁽¹⁾ , V33D = 3 V | | | DGND1 + 0.25 | V |
| V _{OH} | High-level output voltage | I _{OH} = -6 mA ⁽²⁾ , V33D = 3 V | | V33D - 0.6V | | |
| V _{IH} | High-level input voltage | V33D = 3V | 2.1 | | 3.6 | V |
| V _{IL} | Low-level input voltage | V33D = 3.5 V | | | 1.4 | |
| I _{OH(MAX)} | Output high source current | | | | 4 | mA |
| I _{OL(MAX)} | Output low sink current | | | | 4 | |
| SYSTEM PERFORMANCE | | | | | | |
| V _{RESET} | Voltage where device comes out of reset | V33D Pin | 2.3 | | 2.4 | V |
| t _{RESET} | Pulse width needed for reset | RESET pin | 2 | | | |
| F _{SW} | Switching Frequency | | 110 | | 205 | kHz |

(1) The maximum I_{OL}, for all outputs combined, should not exceed 12 mA to hold the maximum voltage drop specified.

(2) The maximum I_{OH}, for all outputs combined, should not exceed 48 mA to hold the maximum voltage drop specified.

ELECTRICAL CHARACTERISTICS (continued)

over operating free-air temperature range (unless otherwise noted)

| PARAMETER | TEST CONDITIONS | MIN | NOM | MAX | UNIT |
|-----------------|--|--------------------|-----|-----|----------|
| t_{detect} | Time to detect presence of device requesting power | | | 0.6 | sec |
| $t_{retention}$ | Retention of configuration parameters | $T_J = 25^\circ C$ | 100 | | Years |
| Write_Cycles | Number of nonvolatile erase/write cycles | $T_J = 25^\circ C$ | 20 | | K cycles |

DEVICE INFORMATION

Functional Block Diagram

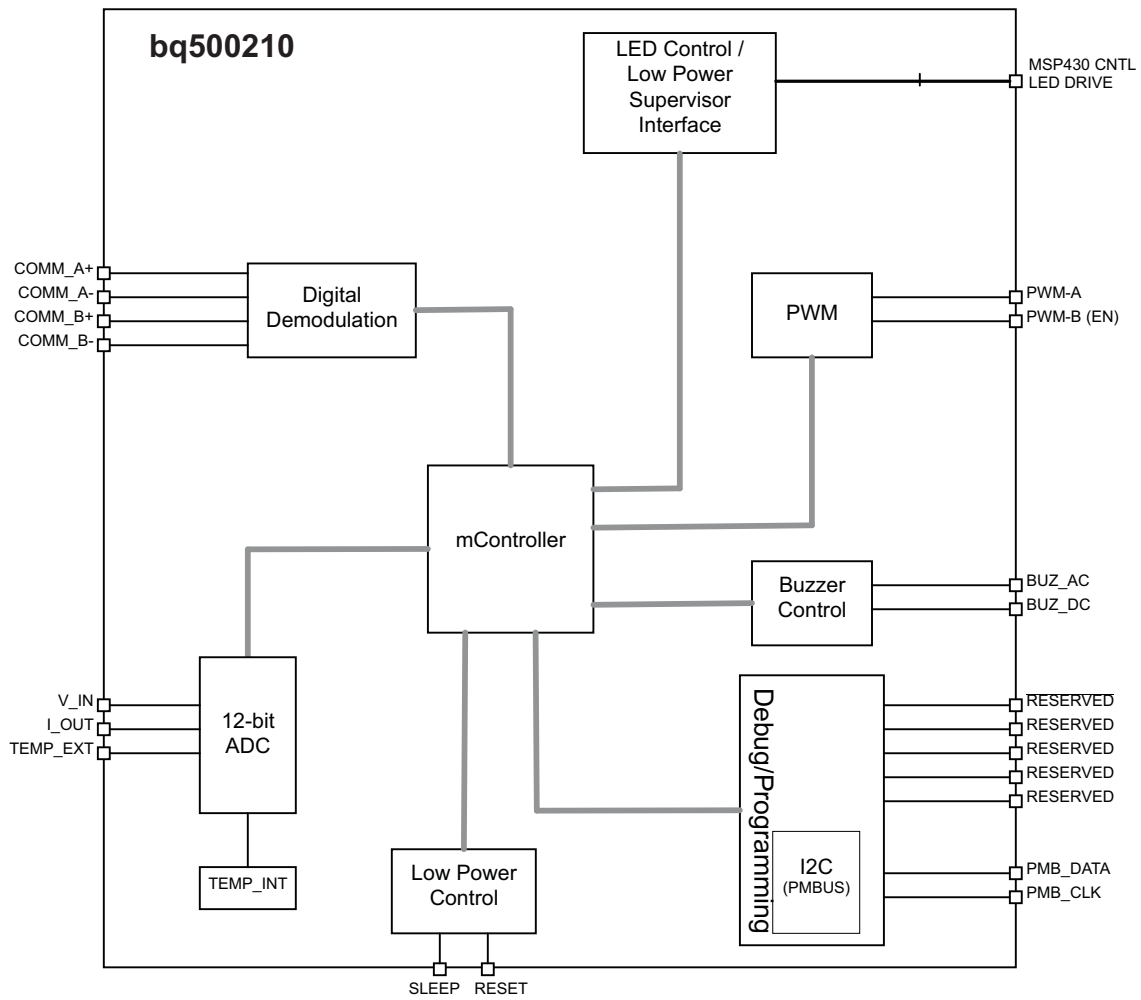

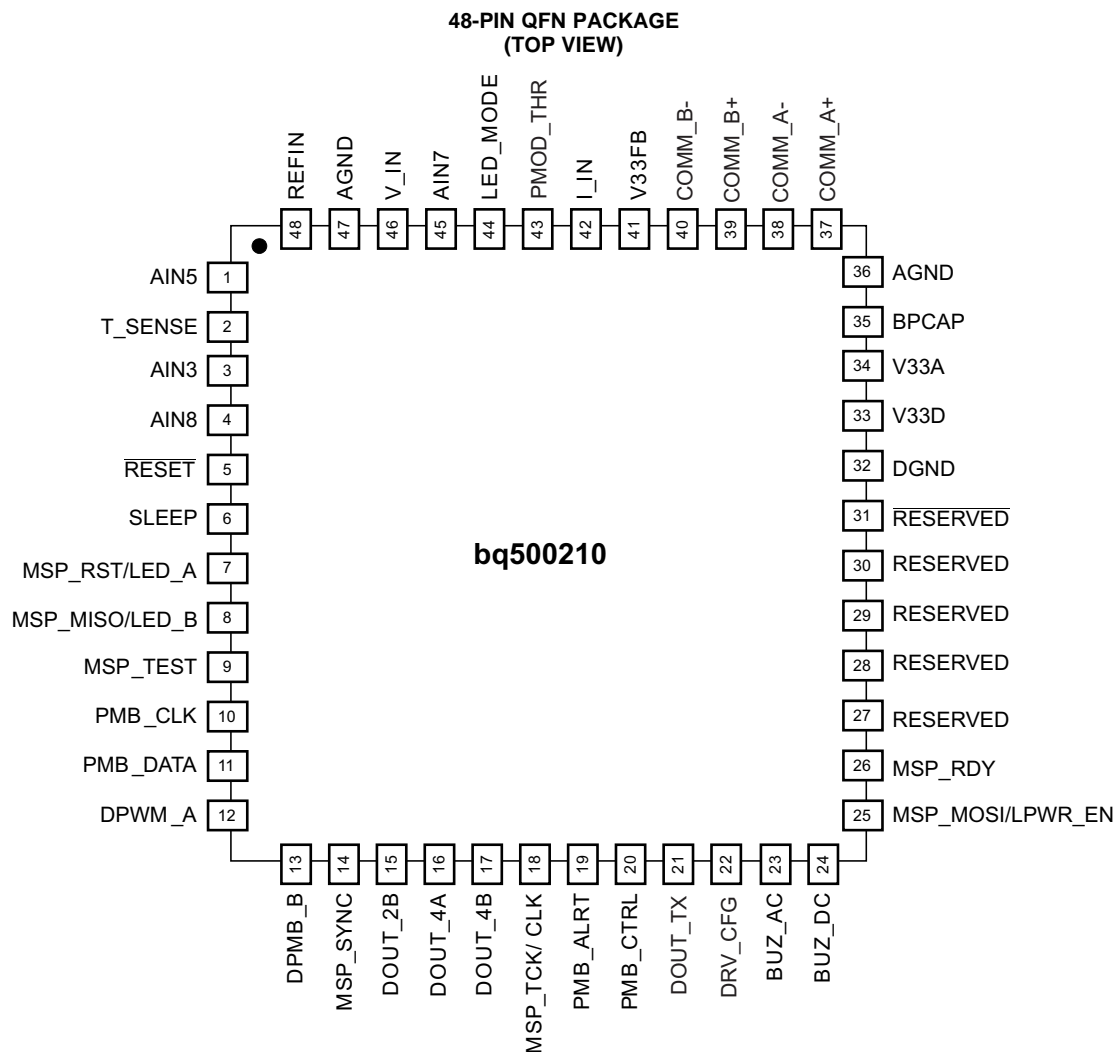

PIN FUNCTIONS

| PIN | | I/O | DESCRIPTION |
|-----|----------------|-----|-----------------------------------|
| NO. | NAME | | |
| 1 | AIN5 | I | Connect this pin to GND |
| 2 | T_SENSE | I | Thermal Sensor Input |
| 3 | AIN3 | I | Connect this pin to GND |
| 4 | AIN8 | I | Connect this pin to GND |
| 5 | RESET | I | Device reset |
| 6 | SLEEP | O | Low-power mode start logic output |
| 7 | MSP_RST/LED_A | I | MSP – Reset, LED-A |
| 8 | MSP_MISO/LED_B | I | MSP – TMS, SPI-MISO, LED-B |
| 9 | MSP_TEST | I | MSP – Test |
| 10 | PMB_CLK | I/O | PMBus Clock |
| 11 | PMB_DATA | I/O | PMBus Data |
| 12 | DPWM_A | O | PWM Output A |
| 13 | DPMB_B | O | PWM Output B |
| 14 | MSP_SYNC | O | MSP SPI_SYNC |

PIN FUNCTIONS (continued)

| PIN | | I/O | DESCRIPTION |
|-----|------------------|-----|---|
| NO. | NAME | | |
| 15 | DOUT_2B | O | Optional Logic Output 2B. Leave this pin floating. |
| 16 | DOUT_4A | O | Optional Logic Output 4A. Leave this pin floating. |
| 17 | DOUT_4B | O | Optional Logic Output 4B. Leave this pin floating. |
| 18 | MSP_TCK/CLK | I/O | Disable Diagnostic Output. Leave this pin floating to inhibit diagnostic. |
| 19 | PMB_ALERT | O | PMBus Interface |
| 20 | PMB_CTRL | I | PMBus Interface |
| 21 | DOUT_TX | I | Leave this pin floating |
| 22 | DRV_CFG | I | Pull this input to V33D |
| 23 | BUZ_AC | O | AC Buzzer Output |
| 24 | BUZ_DC | O | DC Buzzer Output |
| 25 | MSP_MOSI/LPWR_EN | I/O | MSP-TDI, SPI-MOSI, Low Power Enable |
| 26 | MSP_RDY | I/O | MSP-TDO, Programmed Indicator |
| 27 | RESERVED | I/O | Reserved, for factory use only |
| 28 | RESERVED | I/O | Reserved, for factory use only |
| 29 | RESERVED | I/O | Reserved, for factory use only |
| 30 | RESERVED | I/O | Reserved, for factory use only |
| 31 | RESERVED | I/O | Reserved, for factory use only |
| 32 | DGND | — | Digital GND |
| 33 | V33D | — | Digital Core 3.3V Supply |
| 34 | V33A | — | Analog 3.3V Supply |
| 35 | BPCAP | — | Bypass Capacitor Connect Pin |
| 36 | AGND | — | Analog GND |
| 37 | COMM_A+ | I | Digital demodulation noninverting input A |
| 38 | COMM_A- | I | Digital demodulation inverting input A |
| 39 | COMM_B+ | I | Digital demodulation noninverting input B |
| 40 | COMM_B- | I | Digital demodulation inverting input B |
| 41 | V33FB | I | 3.3V Linear-Regulator Feedback Input. Leave this pin floating. |
| 42 | I_IN | I | Transmitter Input Current |
| 43 | PMOD_THR | I | Input to Program Metal Object Detection Threshold |
| 44 | LED_MODE | I | Input to Select LED Mode |
| 45 | AIN7 | I | Reserved Analog Input. Connect this pin to GND. |
| 46 | V_IN | I | Transmitter Input Voltage |
| 47 | AGND | — | Analog GND |
| 48 | REFIN | I | External Reference Voltage Input. Connect this Input to AGND. |

TYPICAL CHARACTERISTICS

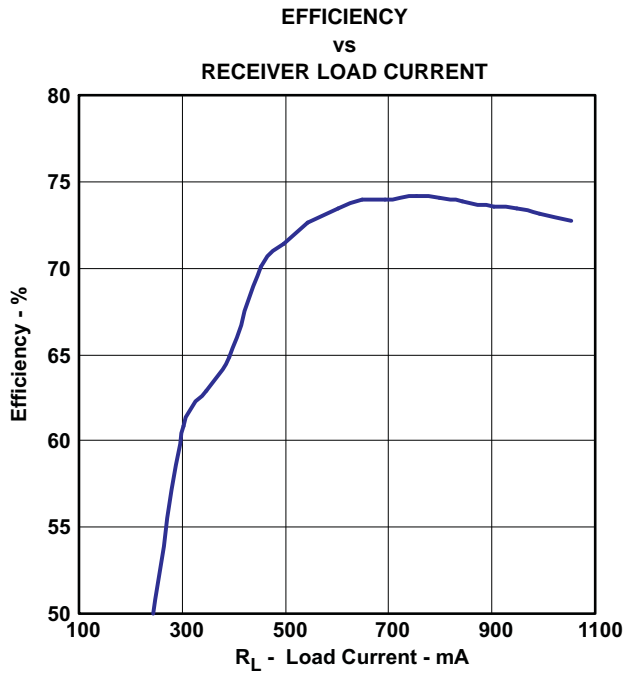

Figure 1.

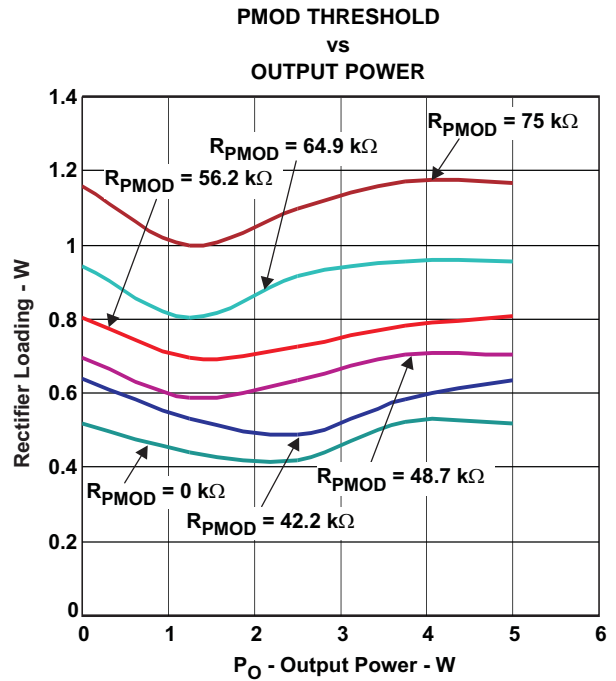

Figure 2.

FUNCTIONAL OVERVIEW

The typical Wireless Power Transfer System consists of primary and secondary coils that are positioned against each other in a way to maximize mutual coupling of their electromagnetic fields. Both coils have ferrite shields as part of their structures to even further maximize field coupling. The primary coil is excited with the switching waveform of the transmitter power driver that gets its power from an AC-DC wall adapter. The secondary coil is connected to the rectifier that can either directly interface the battery or can have an electronic charger or post-regulator connected to its output. The capacitors in series with the coils are tuned to create resonance in the system. The system being in resonance facilitates better energy transfer compared to inductive transfer. Power transfer in the resonant system can also be easily controlled with the variable frequency control approach. To limit operating frequency variation the bq500210 uses both frequency and PWM methods to control power transfer. When the operating frequency approaches a 205kHz limit and the receiver still commands lower power, the bq500210 will reduce the PWM cycle in discrete steps to maintain the output in regulation.

The rectifier output voltage is monitored by the secondary side microcontroller that generates signals to control the modulation circuit to pass coded information from the secondary side to the primary side. The coded information is organized into information packets that have Preamble bytes, Header bytes, message bytes and Checksum bytes. Per the WPC specification, information packets can be related to Identification, Configuration, Control Error, Rectified Power, Charge Status, and End of Power Transfer information. For detailed information on the WPC specification, visit the Wireless Power Consortium website at <http://www.wirelesspowerconsortium.com/>.

There are two ways the coupled electromagnetic field can be manipulated to achieve information transfer from the secondary side to the primary side. With the resistive modulation approach shown in [Figure 3](#), the communication resistor periodically loads the rectifier output changing system Q factor, and as a result the value of the voltage on the primary side coil. With the capacitive modulation approach shown in [Figure 4](#), a pair of communication capacitors are periodically connected to the receiver coil network. These extra capacitance application changes slightly the resonance frequency of the system and its response on the current operating frequency, which in turn leads to coil voltage variation on the primary side.

With both modulation techniques primary side coil waveform variations are detected with a Digital Demodulation algorithm in the bq500210 to restore the content of the information packets and adjust controls to the transmitter.

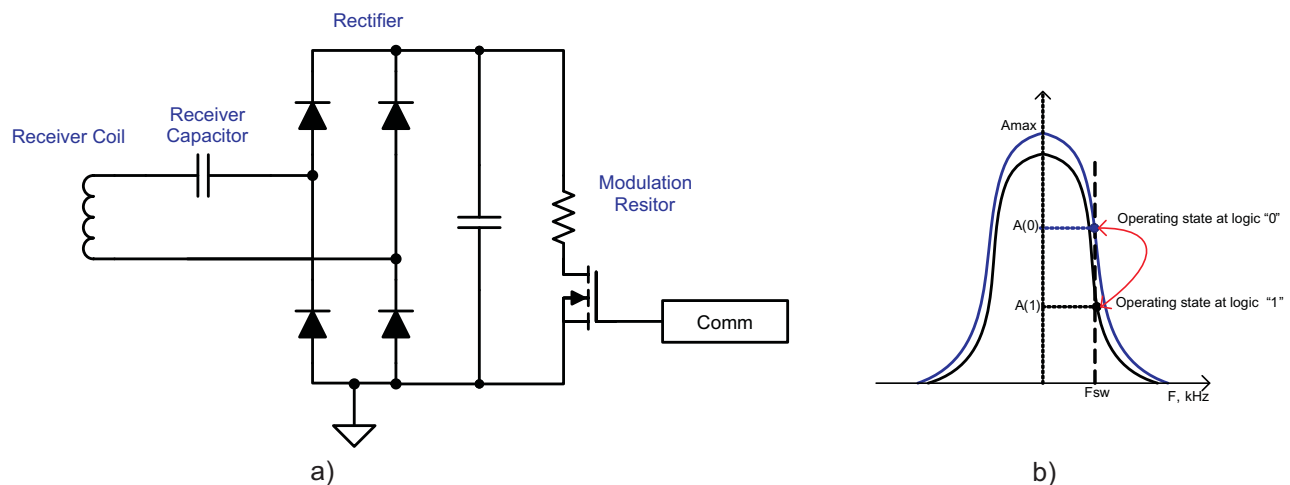

Figure 3. Resistive Modulation Circuit

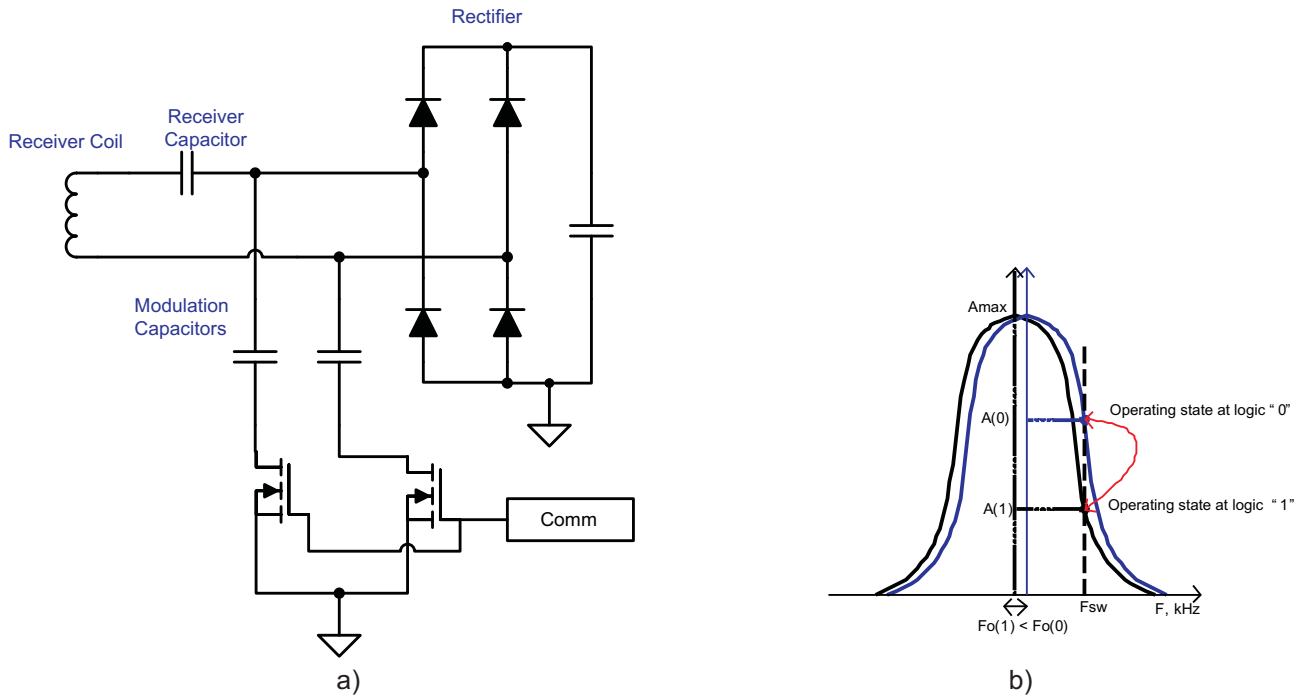

Figure 4. Capacitive Modulation Circuit

The bq500210 is a second generation wireless power dedicated transmitter controller that simplifies integration of wireless power technology into consumer electronics, such as digital cameras, smart phones, MP3 players, and global positioning systems, along with infrastructure applications such as furniture and cars.

The bq500210 is a specialized digital power microcontroller that controls WPC A1, single coil, transmitter functions such as analog ping, digital ping, variable frequency output power control, parasitic metal object detection, over temperature protection of the transmitter top surface, and indication of the transmitter operating states.

The bq500210 digital demodulation inputs receive scaled down voltages from the transmitter resonant components. The digital demodulation algorithm is a combination of several digital signal processing techniques that decodes information packets sent by the power receiving device and provides necessary changes to power drive signals facilitating closed loop regulation. The controller analog inputs monitor input DC voltage, input current, and the thermal protection input. These analog inputs support monitoring and protective functions of the controller.

The bq500210 controls two LEDs to indicate transmitter operating and fault states. Having the LEDs connected directly to the controller simplifies the transmitter electrical schematic and provides a cost effective solution.

Option Select Pins

Two pins (43, 44) in the bq500210 are allocated to program the PMOD mode and the LED mode of the device. At power-up, a bias current is applied to pins LED_MODE and PMOD_THR and the resulting voltage measured in order to identify the value of the attached programming resistor. The values of the operating parameters set by these pins are determined using [Option Select Bins](#). For LED_MODE, the selected bin determines the LED behavior based on [LED Modes](#); for the PMOD_THR, the selected bin sets a threshold used for parasitic metal object detection (see [Metal Object Detection \(PMOD\)](#) section).

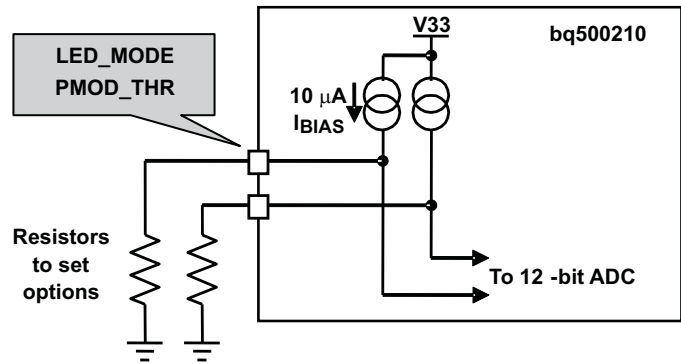

Figure 5. Option Programming

Table 1. Option Select Bins

| BIN NUMBER | RESISTANCE (kΩ) | LED OPTION | PMOD THRESHOLD (mW) ⁽¹⁾ |
|------------|-----------------|------------|------------------------------------|
| 0 | GND | 0 | 500 |
| 1 | 42.2 | 1 | 600 |
| 2 | 48.7 | 2 | 700 |
| 3 | 56.2 | 3 | 800 |
| 4 | 64.9 | 4 | 900 |
| 5 | 75.0 | 5 | 1000 |
| 6 | 86.6 | 6 | 1100 |
| 7 | 100 | 7 | 1200 |
| 8 | 115 | 8 | 1300 |
| 9 | 133 | 9 | 1400 |
| 10 | 154 | 10 | 1500 |
| 11 | 178 | 11 | 1600 |
| 12 | 205 | 12 | 1700 |
| 13 | open | 13 | OFF |

(1) Threshold numbers are approximate. See Figure 2.

LED Modes

The bq500210 can directly control two LED outputs (pins 7 and 8). They are driven based on one of the selectable modes. The resistor connected between pin 44 and GND selects one of the desired LED indication schemes presented in Table 2.

Table 2. LED Modes

| LED Control Option | LED Selection Resistor | Description | LED | Operational States | | | | | Support CS-100 | Support CS-90 | Support CS-6Min |
|--------------------|------------------------|----------------------------------|-------------|--------------------|----------------|-----------------|-------|--------------|----------------|---------------|-----------------|
| | | | | Standby | Power Transfer | Charge Complete | Fault | PMOD Warning | | | |
| 0 | <36.5 kΩ | Reserved for test | LED1, Green | – | – | – | – | – | – | – | – |
| | | | LED2, Red | – | – | – | – | – | | | |
| 1 | 42.2 kΩ | Generic+ CS100 + CS90 + CS6min | LED1, Green | OFF | BLINK SLOW | ON | OFF | OFF | YES | YES | YES |
| | | | LED2, Red | OFF | OFF | OFF | ON | BLINK FAST | | | |
| 2 | 48.7 kΩ | Generic | LED1, Green | OFF | BLINK SLOW | ON | OFF | OFF | NO | NO | NO |
| | | | LED2, Red | OFF | OFF | OFF | OFF | BLINK FAST | | | |
| 3 | 56.2 kΩ | Generic + CS100 | LED1, Green | OFF | BLINK SLOW | ON | ON | OFF | YES | NO | NO |
| | | | LED2, Red | OFF | OFF | OFF | ON | BLINK FAST | | | |
| 4 | 64.9 kΩ | Generic + CS100 + CS90 | LED1, Green | OFF | BLINK SLOW | ON | OFF | OFF | YES | YES | NO |
| | | | LED2, Red | OFF | OFF | OFF | ON | BLINK FAST | | | |
| 5 | 75 kΩ | Generic+ CS100 + CS6min | LED1, Green | OFF | BLINK SLOW | ON | OFF | OFF | YES | NO | YES |
| | | | LED2, Red | OFF | OFF | OFF | ON | BLINK FAST | | | |
| 6 | 86.6 kΩ | Suggested | LED1, Green | ON | BLINK SLOW | ON | OFF | OFF | NO | NO | NO |
| | | | LED2, Red | ON | OFF | OFF | ON | BLINK FAST | | | |
| 7 | 100 kΩ | Suggested + CS100 | LED1, Green | ON | BLINK SLOW | ON | OFF | OFF | YES | NO | NO |
| | | | LED2, Red | ON | OFF | OFF | ON | BLINK FAST | | | |
| 8 | 115 kΩ | Suggested + CS100 + CS90 | LED1, Green | ON | BLINK SLOW | ON | OFF | OFF | YES | YES | NO |
| | | | LED2, Red | ON | OFF | OFF | ON | BLINK FAST | | | |
| 9 | 133 kΩ | Suggested+ CS100 + CS6min | LED1, Green | ON | BLINK SLOW | ON | OFF | OFF | YES | NO | YES |
| | | | LED2, Red | ON | OFF | OFF | ON | BLINK FAST | | | |
| 10 | 154 kΩ | Suggested+ CS100 + CS90 + CS6min | LED1, Green | ON | BLINK SLOW | ON | OFF | OFF | YES | NO | NO |
| | | | LED2, Red | ON | OFF | OFF | ON | BLINK FAST | | | |
| 11 | 178 kΩ | Reserved | LED1, Green | – | – | – | – | – | – | – | – |
| | | | LED2, Red | – | – | – | – | – | | | |
| 12 | 205 kΩ | Reserved | LED1, Green | – | – | – | – | – | – | – | – |
| | | | LED2, Red | – | – | – | – | – | | | |
| 13 | >237 kΩ | Reserved | LED1, Green | – | – | – | – | – | – | – | – |
| | | | LED2, Red | – | – | – | – | – | | | |

Thermal Protection

The bq500210 can provide thermal protection to the transmitter. An external NTC resistor can be placed in the most thermally challenged area, which usually is the center of the transmitting coil, and connected between the dedicated pin 2 and GND. The threshold on pin 2 is set to 1.00V. The NTC resistor and the resistor from pin 2 to V_{CC} create a temperature sensitive divider. The user has full flexibility choosing the NTC resistor and the value of the resistor from pin 2 to V_{CC} to set the desired temperature when the system shuts down.

$$R_{TEMP_IN} = 2.3 \times R_{NTC}(T_{MAX}) \quad (1)$$

The system will attempt to restore normal operation after approximately five minutes of being in the suspended mode due to tripping the over-temperature threshold, or if the receiver is removed. The bq500210 has a built-in thermal sensor that prevents the die temperature from exceeding 135°C. This sensor has ~10°C hysteresis.

Audible Notification on Power Transfer Begin

The bq500210 is capable of activating two types of buzzers to indicate that power transfer has begun. Pin 24 outputs a high logic signal for 0.4s that is suitable to activate DC type buzzers with built in tone generators, or other types of sound generators, or custom indication systems. Pin 23 outputs for 0.4 seconds a 4 kHz square wave signal suitable for inexpensive AC type ceramic buzzers.

Power-On Reset

The bq500210 has an integrated power-on reset (POR) circuit that monitors the supply voltage. At power-up, the POR circuit detects the V_{33D} rise. When V_{33D} is greater than V_{RESET} , the device initiates an internal startup sequence. At the end of the startup sequence, the device begins normal operation.

External Reset

The device can be forced into a reset state by an external circuit connected to the \overline{RESET} pin. A logic low voltage on this pin holds the device in reset. To avoid an erroneous trigger caused by noise, a 10k Ω pull up resistor connected to 3.3V is recommended.

Parasitic Metal Object Detection (PMOD)

As a safety feature, the bq500210 can be configured to detect the presence of a parasitic metal object placed in the vicinity of the magnetic field. The bq500100 uses the Rectified Power Packet information and the measured transmitter input-power to calculate parasitic losses in the system. When an excessive power loss is detected, the device will blink the red LED to warn about this undesirable condition. If during a twenty second warning time the parasitic metal object is not removed, the controller will disable power transfer. After being in halt for five minutes, the bq500210 will attempt normal operation. If the object that caused excessive power dissipation is still present, the sequence will be repeated over and over again. If the metal object is removed during this twenty second warning time, then normal operation will be restored promptly.

To facilitate the parasitic loss function, the bq500210 monitors the input voltage and the input current supplied to the power drive circuit.

The PMOD_THR pin is used to set the threshold at which the PMOD is activated. The highest bin, the pin is left floating, disables the PMOD feature.

Note: The WPC Specification V1.0 does not define the requirements and thresholds for the PMOD feature. Hence, metal object detection may perform differently with different products. Therefore, the threshold setting is determined by the user. In most desktop wireless charger applications, a PMOD threshold setting of 0.8W has shown to provide acceptable results in stopping power transfer and preventing small metal objects like coins, pharmaceutical wraps, etc. from becoming dangerously hot when placed in the path of the wireless power transfer. [Figure 2](#) depicts PMOD performance measured on a bq500210 EVM with a bq51013 EVM. The parasitic metal loss is emulated by loading the output of the rectifier in the bq51013 EVM.

ADVANCED CHARGE INDICATION SCHEMES

The WPC specification provides an End of Power Transfer message (EPT-01) to indicate charge complete. Upon receipt of the charge complete message, the bq500210 will change the LED indication as defined by the LED_MODE pin (normally solid green LED output), and halt power transfer for 5 minutes.

In some battery charging applications there is a benefit to continue the charging process in trickle charge mode to top off the battery. There are several information packets in the WPC specification related to the levels of battery charge – Charge Status. The bq500210 uses these commands in association with some of the LED modes described in [Table 2](#) to enable the top-off charging pattern. When CS100 LED mode is enabled, the bq500210 will change the LED indication to reflect charge complete when a Charge Status = 100% message is received, but unlike the response to an EPT, it will not halt power transfer while the LED is solid green. The mobile device can use a CS100 packet to enable trickle charge mode.

Note that all options related to CS100 have an effect on the LEDs only; they do not have any impact on actual power transfer which continues uninterrupted.

Two more optional modes are available which can be used to change the LED mode back to indicate charging after the CS100 has forced the charge complete output:

- If CS90 is enabled, a Charge Status message indicating less than 90% charge will force the LED output to indicate charging (typically a slow blinking green LED).
- When CS6MIN is enabled, and if the bq500210 does not detect another CS100 packet for six minutes, it will assume the receiver charge has dropped significantly and will turn on charging status indication.

APPLICATION INFORMATION

The application diagram for the transmitter with reduced standby power consumption is shown in [Figure 6](#).

Power reduction is achieved by periodically shutting down the bq500210 while LED and housekeeping control functions are continued by U4 – the low-cost, low quiescent current microcontroller MSP430G2001. When U4 is present in the circuit (which is set by a pull-up resistor on bq500210 pin 25), the bq500210 at first power-up boots the MSP430G2001 with the necessary firmware and the two chips operate in tandem.

During standby operation, the bq500210 periodically issues SLEEP command, Q12 pulls down the enable pin on U2, the TLV70033 LDO, which shut off power to the bq500210.

Meanwhile, the MSP430G2001 maintains the LED indication and stores previous charge state during this bq500210 shut-off period.

This bq500210 shut-off period is set by the RC time constant network of R25, C38 (from [Figure 6](#)). WPC compliance mandates the power transmitter controller awakes every 0.4s to produce an analog ping and check if a valid device is present. Altering this time constant, therefore, is not advised.

Note: The user does not need to program the MSP430G2001, an off-the-shelf part can be used! The user cannot modify or customize this firmware.

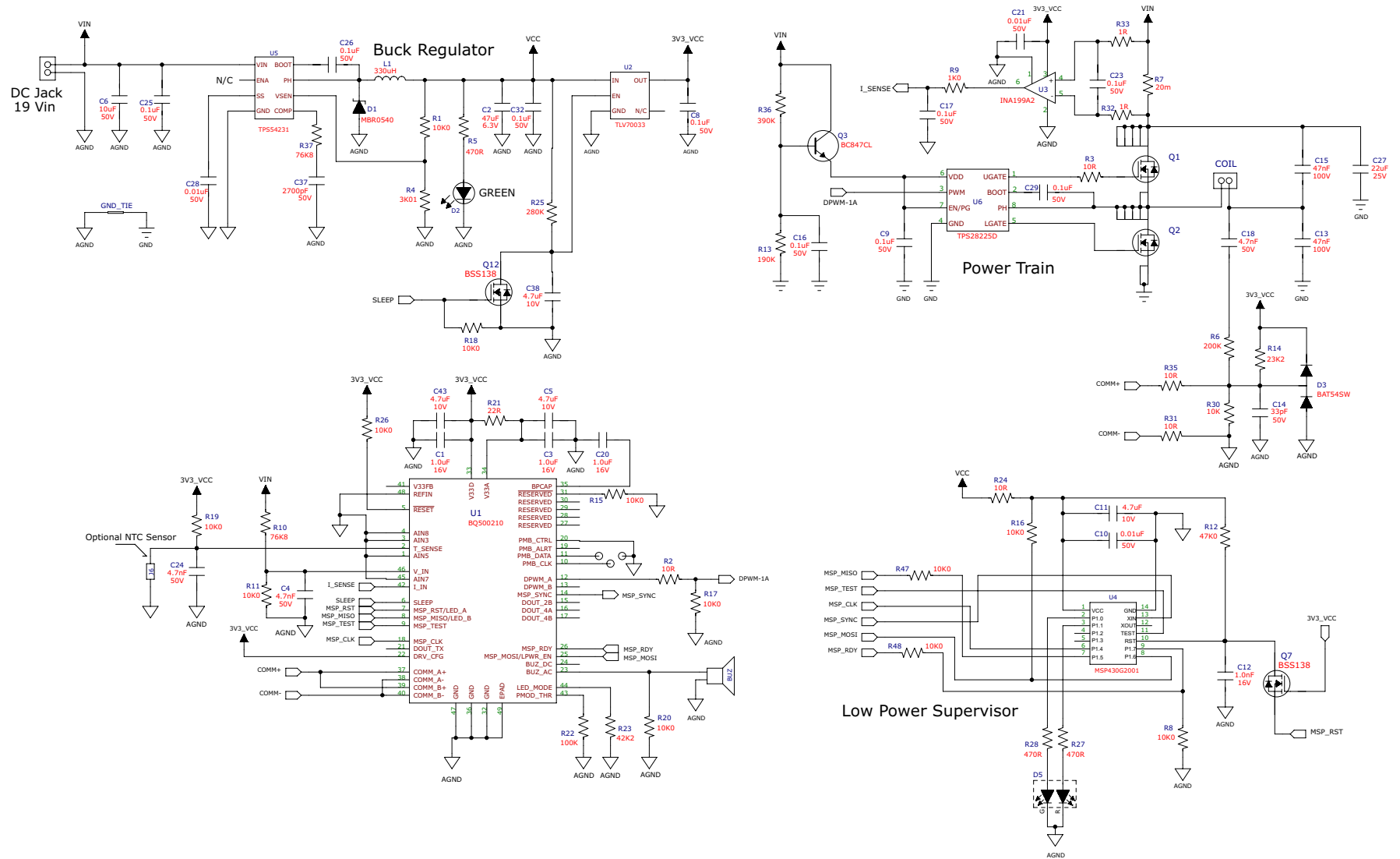

Figure 6. Typical Application Diagram for Wireless Power Transmitter with Reduced Standby Power

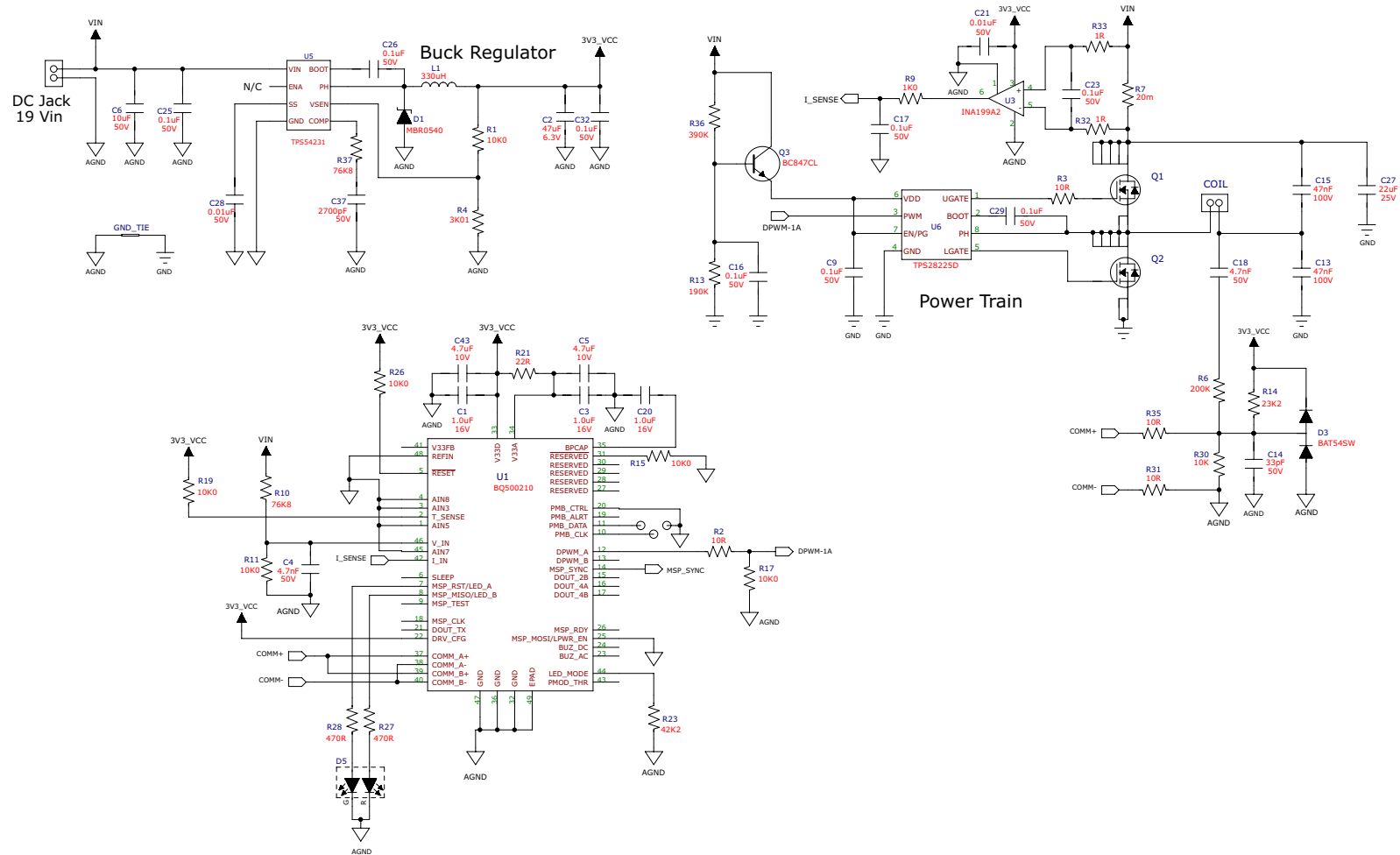

Figure 7. Typical Application Diagram for Wireless Power Transmitter

REVISION HISTORY

| Changes from Original (June 2011) to Revision A | Page |
|---|-------------|
| • Changed APPLICATION INFORMATION description | 13 |
| • Changed Figure 6 | 14 |
| Changes from Revision A (August 2011) to Revision B | |
| • Changed APPLICATION INFORMATION description | 13 |
| • Changed Figure 6 | 14 |
| • Changed Figure 7 | 15 |
| Changes from Revision B (July 2012) to Revision C | |
| • Changed Functional Block Diagram | 4 |
| • Changed pinout | 5 |
| • Changed pin 26 to MSP_RDY | 6 |
| • Changed pins 27-31 to Reserved, for factory use only in PIN FUNCTIONS | 6 |

PACKAGING INFORMATION

| Orderable Device | Status (1) | Package Type | Package Drawing | Pins | Package Qty | Eco Plan (2) | Lead finish/ Ball material (6) | MSL Peak Temp (3) | Op Temp (°C) | Device Marking (4/5) | Samples |
|------------------|---------------|--------------|--------------------|------|----------------|-----------------|--------------------------------------|----------------------|--------------|-------------------------|---------|
| BQ500210RGZR | NRND | VQFN | RGZ | 48 | 2500 | RoHS & Green | NIPDAU | Level-3-260C-168 HR | -40 to 110 | BQ500210 | |
| BQ500210RGZT | NRND | VQFN | RGZ | 48 | 250 | RoHS & Green | NIPDAU | Level-3-260C-168 HR | -40 to 110 | BQ500210 | |

(1) The marketing status values are defined as follows:

ACTIVE: Product device recommended for new designs.

LIFEBUY: TI has announced that the device will be discontinued, and a lifetime-buy period is in effect.

NRND: Not recommended for new designs. Device is in production to support existing customers, but TI does not recommend using this part in a new design.

PREVIEW: Device has been announced but is not in production. Samples may or may not be available.

OBSOLETE: TI has discontinued the production of the device.

(2) **RoHS:** TI defines "RoHS" to mean semiconductor products that are compliant with the current EU RoHS requirements for all 10 RoHS substances, including the requirement that RoHS substance do not exceed 0.1% by weight in homogeneous materials. Where designed to be soldered at high temperatures, "RoHS" products are suitable for use in specified lead-free processes. TI may reference these types of products as "Pb-Free".

RoHS Exempt: TI defines "RoHS Exempt" to mean products that contain lead but are compliant with EU RoHS pursuant to a specific EU RoHS exemption.

Green: TI defines "Green" to mean the content of Chlorine (Cl) and Bromine (Br) based flame retardants meet JS709B low halogen requirements of <=1000ppm threshold. Antimony trioxide based flame retardants must also meet the <=1000ppm threshold requirement.

(3) MSL, Peak Temp. - The Moisture Sensitivity Level rating according to the JEDEC industry standard classifications, and peak solder temperature.

(4) There may be additional marking, which relates to the logo, the lot trace code information, or the environmental category on the device.

(5) Multiple Device Markings will be inside parentheses. Only one Device Marking contained in parentheses and separated by a "~" will appear on a device. If a line is indented then it is a continuation of the previous line and the two combined represent the entire Device Marking for that device.

(6) Lead finish/Ball material - Orderable Devices may have multiple material finish options. Finish options are separated by a vertical ruled line. Lead finish/Ball material values may wrap to two lines if the finish value exceeds the maximum column width.

Important Information and Disclaimer:The information provided on this page represents TI's knowledge and belief as of the date that it is provided. TI bases its knowledge and belief on information provided by third parties, and makes no representation or warranty as to the accuracy of such information. Efforts are underway to better integrate information from third parties. TI has taken and continues to take reasonable steps to provide representative and accurate information but may not have conducted destructive testing or chemical analysis on incoming materials and chemicals. TI and TI suppliers consider certain information to be proprietary, and thus CAS numbers and other limited information may not be available for release.

In no event shall TI's liability arising out of such information exceed the total purchase price of the TI part(s) at issue in this document sold by TI to Customer on an annual basis.

TAPE AND REEL INFORMATION

QUADRANT ASSIGNMENTS FOR PIN 1 ORIENTATION IN TAPE

*All dimensions are nominal

| Device | Package Type | Package Drawing | Pins | SPQ | Reel Diameter (mm) | Reel Width W1 (mm) | A0 (mm) | B0 (mm) | K0 (mm) | P1 (mm) | W (mm) | Pin1 Quadrant |
|--------------|--------------|-----------------|------|------|--------------------|--------------------|---------|---------|---------|---------|--------|---------------|
| BQ500210RGZR | VQFN | RGZ | 48 | 2500 | 330.0 | 16.4 | 7.3 | 7.3 | 1.5 | 12.0 | 16.0 | Q2 |
| BQ500210RGZR | VQFN | RGZ | 48 | 2500 | 330.0 | 16.4 | 7.3 | 7.3 | 1.1 | 12.0 | 16.0 | Q2 |
| BQ500210RGZT | VQFN | RGZ | 48 | 250 | 180.0 | 16.4 | 7.3 | 7.3 | 1.5 | 12.0 | 16.0 | Q2 |

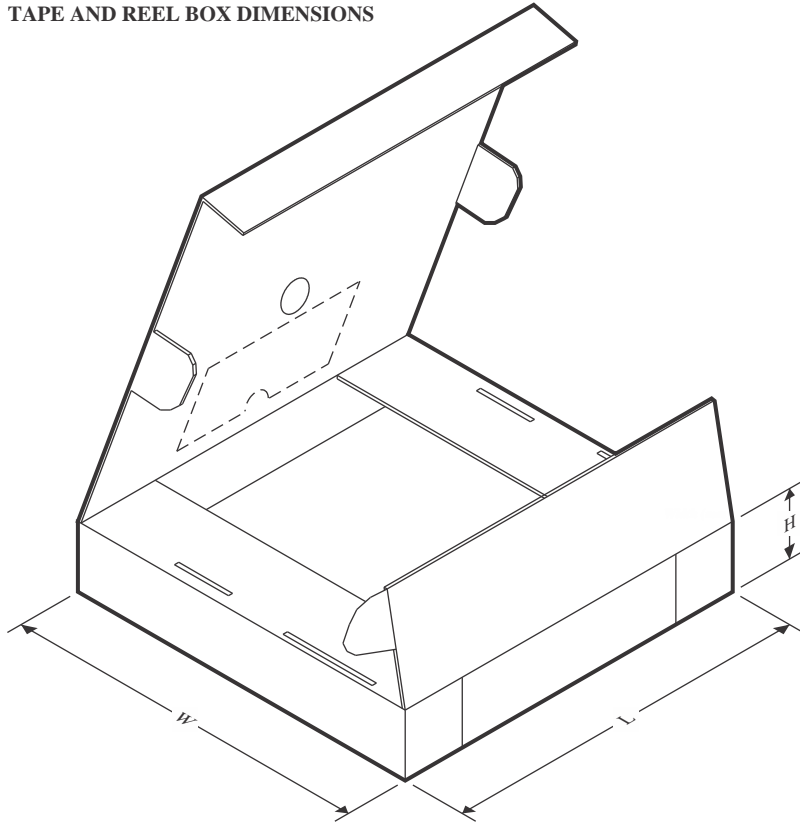
TAPE AND REEL BOX DIMENSIONS

*All dimensions are nominal

| Device | Package Type | Package Drawing | Pins | SPQ | Length (mm) | Width (mm) | Height (mm) |
|--------------|--------------|-----------------|------|------|-------------|------------|-------------|
| BQ500210RGZR | VQFN | RGZ | 48 | 2500 | 356.0 | 356.0 | 35.0 |
| BQ500210RGZR | VQFN | RGZ | 48 | 2500 | 367.0 | 367.0 | 38.0 |
| BQ500210RGZT | VQFN | RGZ | 48 | 250 | 210.0 | 185.0 | 35.0 |

GENERIC PACKAGE VIEW

RGZ 48

VQFN - 1 mm max height

7 x 7, 0.5 mm pitch

PLASTIC QUADFLAT PACK- NO LEAD

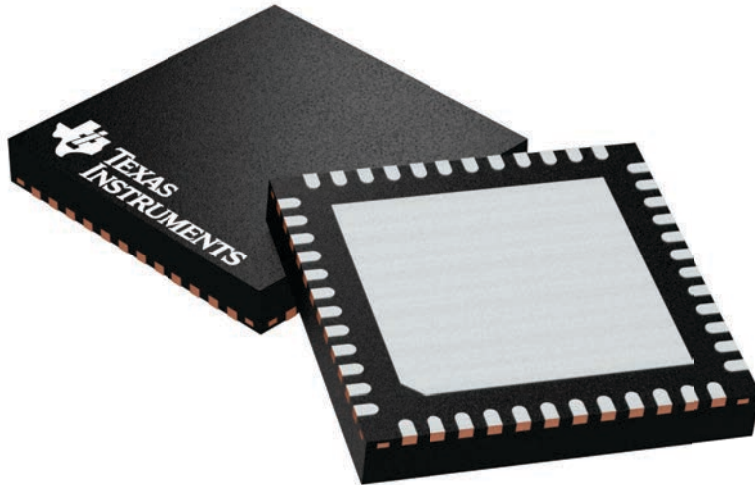

Images above are just a representation of the package family, actual package may vary.
Refer to the product data sheet for package details.

4224671/A



4219044/D 02/2022

NOTES:

1. All linear dimensions are in millimeters. Any dimensions in parenthesis are for reference only. Dimensioning and tolerancing per ASME Y14.5M.
2. This drawing is subject to change without notice.
3. The package thermal pad must be soldered to the printed circuit board for optimal thermal and mechanical performance.



NOTES: (continued)

4. This package is designed to be soldered to a thermal pad on the board. For more information, see Texas Instruments literature number SLUA271 (www.ti.com/lit/sluea271).
5. Vias are optional depending on application, refer to device data sheet. If any vias are implemented, refer to their locations shown on this view. It is recommended that vias under paste be filled, plugged or tented.

EXAMPLE STENCIL DESIGN

RGZ0048A

VQFN - 1 mm max height

PLASTIC QUADFLAT PACK- NO LEAD



NOTES: (continued)

6. Laser cutting apertures with trapezoidal walls and rounded corners may offer better paste release. IPC-7525 may have alternate design recommendations.

IMPORTANT NOTICE AND DISCLAIMER

TI PROVIDES TECHNICAL AND RELIABILITY DATA (INCLUDING DATA SHEETS), DESIGN RESOURCES (INCLUDING REFERENCE DESIGNS), APPLICATION OR OTHER DESIGN ADVICE, WEB TOOLS, SAFETY INFORMATION, AND OTHER RESOURCES "AS IS" AND WITH ALL FAULTS, AND DISCLAIMS ALL WARRANTIES, EXPRESS AND IMPLIED, INCLUDING WITHOUT LIMITATION ANY IMPLIED WARRANTIES OF MERCHANTABILITY, FITNESS FOR A PARTICULAR PURPOSE OR NON-INFRINGEMENT OF THIRD PARTY INTELLECTUAL PROPERTY RIGHTS.

These resources are intended for skilled developers designing with TI products. You are solely responsible for (1) selecting the appropriate TI products for your application, (2) designing, validating and testing your application, and (3) ensuring your application meets applicable standards, and any other safety, security, regulatory or other requirements.

These resources are subject to change without notice. TI grants you permission to use these resources only for development of an application that uses the TI products described in the resource. Other reproduction and display of these resources is prohibited. No license is granted to any other TI intellectual property right or to any third party intellectual property right. TI disclaims responsibility for, and you will fully indemnify TI and its representatives against, any claims, damages, costs, losses, and liabilities arising out of your use of these resources.

TI's products are provided subject to [TI's Terms of Sale](#) or other applicable terms available either on ti.com or provided in conjunction with such TI products. TI's provision of these resources does not expand or otherwise alter TI's applicable warranties or warranty disclaimers for TI products.

TI objects to and rejects any additional or different terms you may have proposed.

Mailing Address: Texas Instruments, Post Office Box 655303, Dallas, Texas 75265
Copyright © 2022, Texas Instruments Incorporated