

12	11	10	9	8	7	6	5	4	3	2	1					
UNPLATED MATERIAL NUMBER	UNPLATED ENG. NUMBER	UNPLATED MAT. NO. ON TAPE	UNPLATED ENG. NO. ON TAPE	PLATED MATERIAL NUMBER	PLATED ENGINEERING NUMBER	PLATED MAT. NO. ON TAPE	PLATED ENG. NO. ON TAPE	SEE DETAIL	STUD SIZE	WIRE RANGE	"S" ±.015/0.38	"L" ±.050/1.27	L4 "W" ±.050/1.27	"C" ±.050/1.27	"B" ±.020/0.51	"T" ±.020/0.51
192210408	BCL-810	---	---	192210223	BCL-810-PL	190820011	BCL-810-PLT	A	10/4.8mm	8 AWG/10mm <sup>2</sup>	.214/5.45	1.187/30.15	.438/11.13	.376/9.55	.185/4.70	.070/1.78
192210409	BCL-814	190820014	BCL-814T	192210224	BCL-814-PL	190820013	BCL-814-PLT	A	1/4"/M6	8 AWG/10mm <sup>2</sup>	.278/7.06	1.187/30.15	.438/11.13	.376/9.55	.185/4.70	.070/1.78
192210562	BCL-814-WP	---	---	192210563	BCL-814-WP-PL	---	---	---	1/4"/M6	8 AWG/10mm <sup>2</sup>	.278/7.06	1.313/33.35	.594/15.09	.422/10.72	.185/4.70	.070/1.78
192210411	BCL-8516	---	---	192210225	BCL-8516-PL	---	---	A	5/16"/M8	8 AWG/10mm <sup>2</sup>	.340/8.63	1.187/30.15	.438/11.13	.376/9.55	.185/4.70	.070/1.78
192210482	BCL-8516-WP	---	---	192210483	BCL-8516-WP-PL	190820016	BCL-8516-PLT	B	5/16"/M8	8 AWG/10mm <sup>2</sup>	.340/8.63	1.313/33.35	.594/15.09	.422/10.72	.185/4.70	.070/1.78
192210410	BCL-838-WP	190820015	BCL-838-WPT	192210226	BCL-838-WP-PL	192210566	BCL-838-WP-PLT	B	3/8"/M9	8 AWG/10mm <sup>2</sup>	.400/10.16	1.313/33.35	.594/15.09	.422/10.72	.185/4.70	.070/1.78
192210481	BCL-838-XWP	---	---	192210484	BCL-838-XWP-PL	---	---	---	3/8"/M9	8 AWG/10mm <sup>2</sup>	.400/10.16	1.469/37.31	.766/19.46	.394/10.01	.185/4.70	.070/1.78
192210415	BCL-812-XWP	---	---	192210414	BCL-812-XWP-PL	---	---	---	1/2"/M12	8 AWG/10mm <sup>2</sup>	.520/13.21	1.469/37.31	.766/19.46	.394/10.01	.185/4.70	.070/1.78
192210425	BCL-610	---	---	192210424	BCL-610-PL	190820003	BCL-610-PLT	B	10/4.8mm	6 AWG/16mm <sup>2</sup>	.214/5.45	1.281/32.54	.438/11.13	.381/9.68	.232/5.89	.075/1.90
192210406	BCL-614-WP	---	---	192210227	BCL-614-WP-PL	190820005	BCL-614-PLT	B	1/4"/M6	6 AWG/16mm <sup>2</sup>	.278/7.06	1.406/35.72	.594/15.09	.427/10.85	.232/5.89	.080/2.03
192210494	BCL-614	---	---	192210495	BCL-614-PL	192210498	BCL-614-PLT	B	1/4"/M6	6 AWG/16mm <sup>2</sup>	.278/7.06	1.281/32.54	.438/11.13	.381/9.68	.232/5.89	.075/1.90
192210407	BCL-6516-WP	---	---	192210228	BCL-6516-WP-PL	190820009	BCL-6516-PLT	B	5/16"/M8	6 AWG/16mm <sup>2</sup>	.340/8.63	1.406/35.72	.594/15.09	.427/10.85	.232/5.89	.080/2.03
192210493	BCL-6516	190820010	BCL-6516T	192210492	BCL-6516-PL	---	---	B	5/16"/M8	6 AWG/16mm <sup>2</sup>	.340/8.63	1.281/32.54	.438/11.13	.381/9.68	.232/5.89	.075/1.90
192210384	BCL-638-WP	---	---	192210229	BCL-638-WP-PL	190820007	BCL-638-PLT	B	3/8"/M9	6 AWG/16mm <sup>2</sup>	.400/10.16	1.406/35.72	.594/15.09	.427/10.85	.232/5.89	.080/2.03
L4 ---	---	---	---	---	---	---	---	---	3/8"/M9	6 AWG/16mm <sup>2</sup>	.400/10.16	1.563/39.70	.766/19.46	.472/11.99	.232/5.89	.080/2.03
192210417	BCL-612-XWP	---	---	192210416	BCL-612-XWP-PL	190820004	BCL-612-PLT	B	1/2"/M12	6 AWG/16mm <sup>2</sup>	.520/13.21	1.563/39.70	.766/19.46	.472/11.99	.232/5.89	.080/2.03

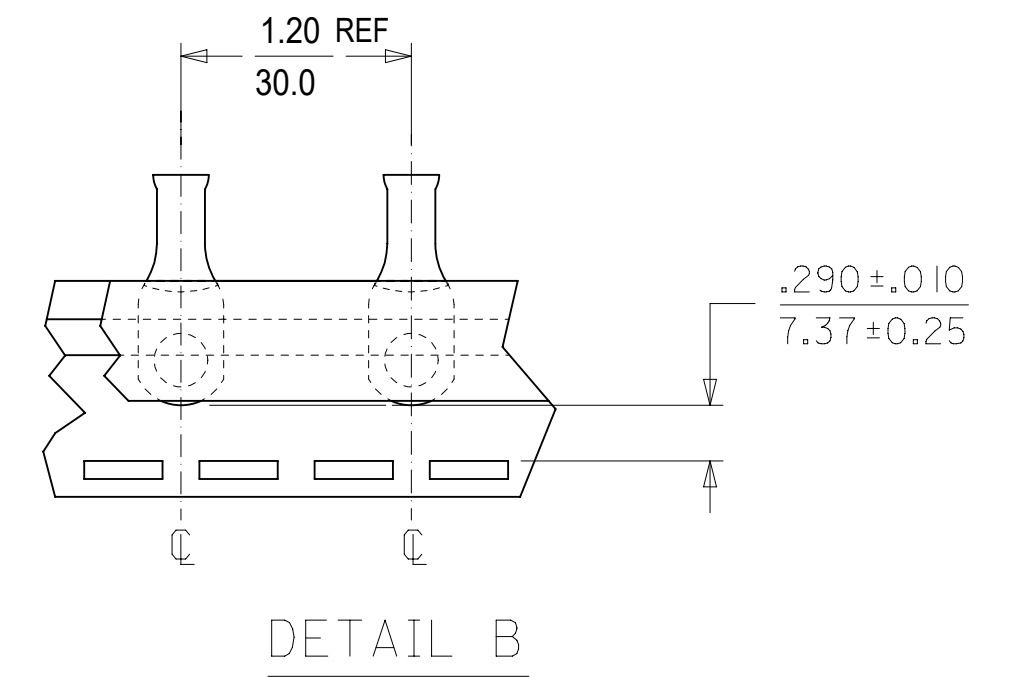
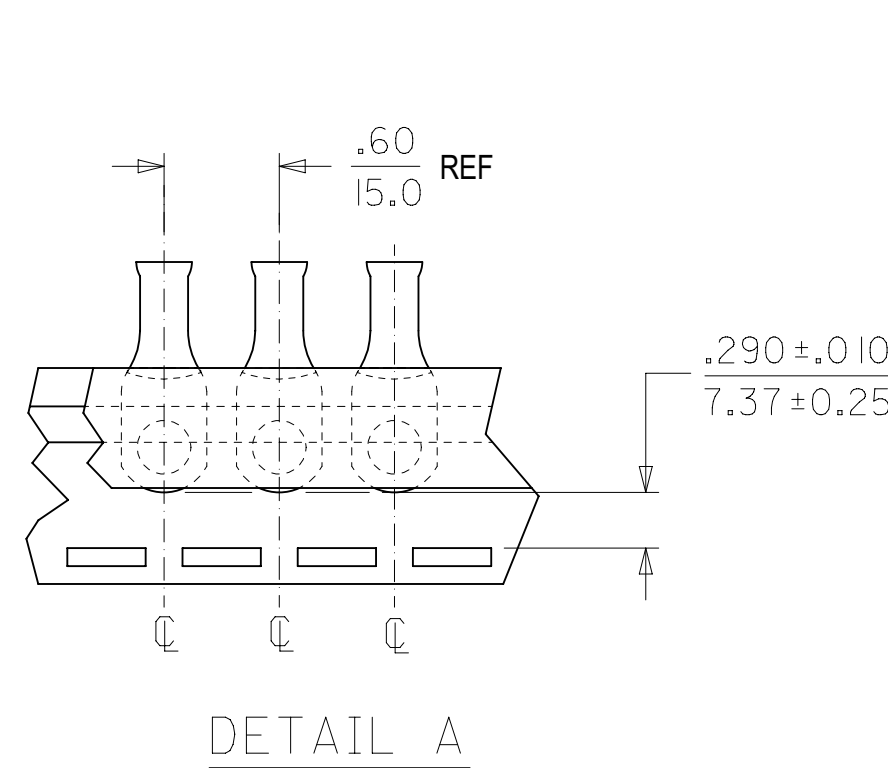
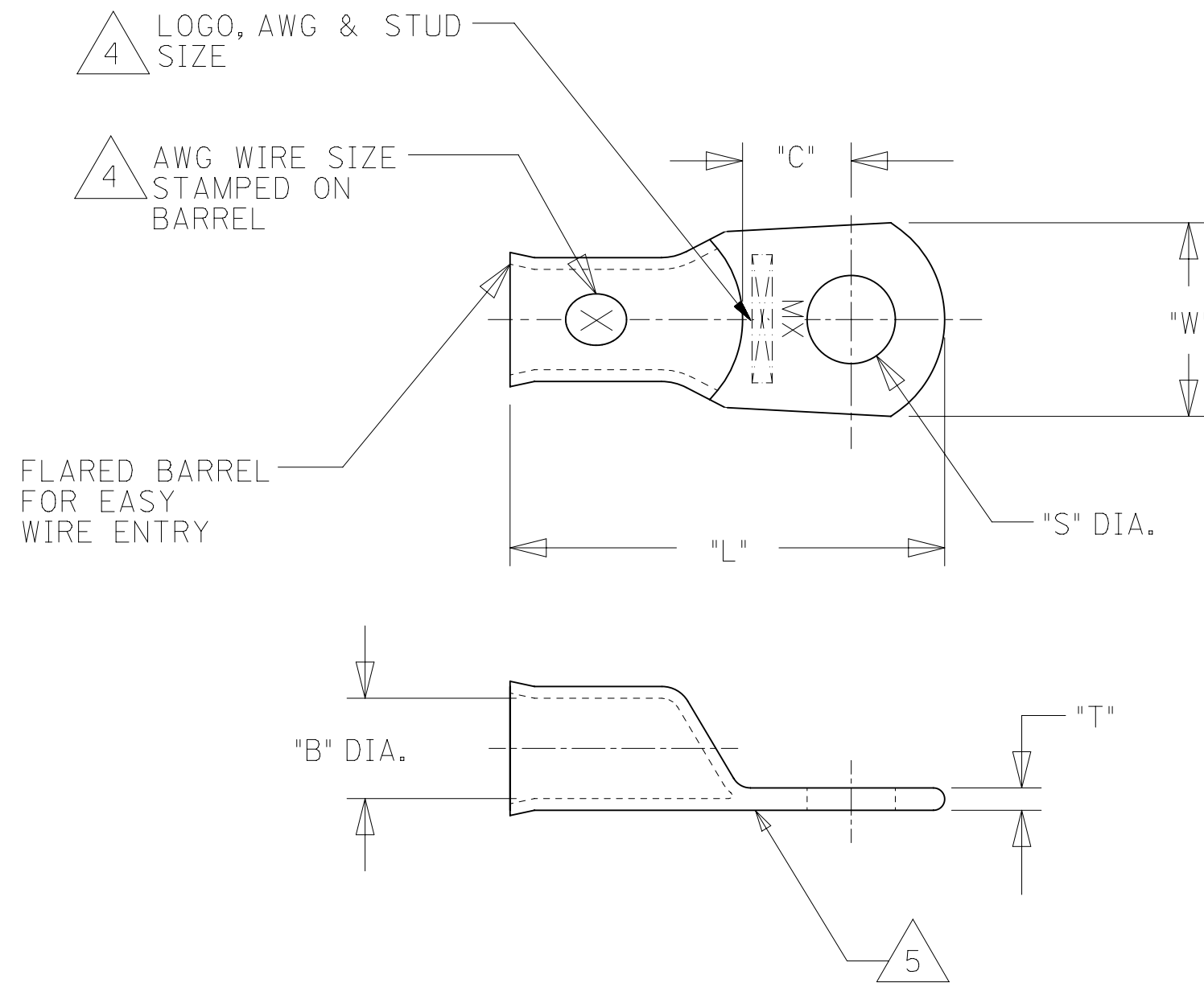

- NOTES:
- FOR INSPECTION SIGHT HOLE, PLEASE CONSULT FACTORY.
  - OTHER STUD SIZES MAY BE AVAILABLE, PLEASE CONSULT FACTORY.
  - MATERIAL: COPPER  
PLATING: TIN
  - MARKINGS CAN BE AT EITHER LOCATION SHOWN.
  - IF TONGUE IS TO BE BENT AT ANY ANGLE, IT MUST BE BENT AROUND A RADIUS ONE HALF THE TONGUE THICKNESS.
  - ALL PARTS ARE RoHS COMPLIANT.

THIS DRAWING CONTAINS INFORMATION THAT IS PROPRIETARY TO MOLEX ELECTRONIC TECHNOLOGIES, LLC AND SHOULD NOT BE USED WITHOUT WRITTEN PERMISSION											
DIMENSION UNITS <b>INCH/MM</b>		SCALE <b>NTS</b>		CURRENT REV DESC: TONGUE WIDTH TOL ± .050 WAS ± .035. PN: 192210569 (BCL-638-XWP) IS NOT ACTIVE.				<b>molex</b>			
GENERAL TOLERANCES (UNLESS SPECIFIED)				EC NO: 676579							
		MM		INCH		DRWN: DMYRICK 2021/09/02		EYELET STYLE		COPPER TERMINALS 8 AND 6 AWG LUGS	
4 PLACES ±		±		±		CHK'D: EJOHNSON04 2021/09/10		PRODUCT CUSTOMER DRAWING			
3 PLACES ±		±		±		APPR: EJOHNSON04 2021/09/10		DOCUMENT NUMBER			
2 PLACES ±		±		±		INITIAL REVISION:		SD-19221-001		DOC TYPE DOC PART REVISION	
1 PLACE ±		±		±		DRWN: DMYRICK 2005/05/03		PSD 001 L4			
0 PLACES ±		±		±		APPR: RDEROSS 2005/05/03		MATERIAL NUMBER		SHEET NUMBER	
ANGULAR TOL ± °		± °		± °		THIRD ANGLE PROJECTION		CUSTOMER		1 OF 1	
DRAFT WHERE APPLICABLE MUST REMAIN WITHIN DIMENSIONS				DRAWING		SERIES		SEE TABLE		GENERAL MARKET	
		C-SIZE		19221							

	10	9	8	7	6	5	4	3	2	1		
	MATERIAL NUMBER	ENGINEERING NUMBER	AWG RANGE	COLOR CODE	STUD SIZE	"S"	"L"	"W"	"P"	"X"	"D"	"T"
F	192210212	HDC-810-CC	8	RED	10	.214	1.125	.343	.531	.250	.250	.078
	192210215	HDC-610-CC	6	BLUE	10	.214	1.187	.406	.562	.250	.281	.078
	192210213	HDC-614-CC	6	BLUE	1/4	.278	1.187	.406	.562	.250	.281	.078
	192210216	HDC-410-CC	4	GRAY	10	.214	1.343	.500	.640	.296	.359	.109
	192210214	HDC-414-CC	4	GRAY	1/4	.278	1.343	.500	.640	.296	.359	.109
	192210217	HDC-4516-CC	4	GRAY	5/16	.340	1.500	.500	.781	.296	.359	.109
	192210218	HDC-214-CC	2	BROWN	1/4	.278	1.343	.609	.671	.296	.437	.125
	192210219	HDC-2516-CC	2	BROWN	5/16	.340	1.343	.609	.671	.296	.437	.125
E	192210220	HDC-238-CC	2	BROWN	3/8	.400	1.750	.609	.968	.390	.437	.125
	192210221	HDC-114-CC	1	GREEN	1/4	.278	1.640	.687	.750	.343	.484	.140
	192210271	HDC-1516-CC	1	GREEN	5/16	.340	1.640	.687	.750	.343	.484	.140
	192210272	HDC-138-CC	1	GREEN	3/8	.400	1.890	.687	1.000	.453	.484	.140
	192210273	HDC-112-CC	1	GREEN	1/2	.520	1.890	.687	1.000	.453	.484	.140
	192210274	HDC-1014-CC	1/0	PINK	1/4	.278	1.796	.765	.781	.375	.531	.140
	192210275	HDC-10516-CC	1/0	PINK	5/16	.340	1.796	.765	.781	.375	.531	.140
	192210276	HDC-1038-CC	1/0	PINK	3/8	.400	2.046	.765	1.031	.453	.531	.140
D	192210277	HDC-1012-CC	1/0	PINK	1/2	.520	2.046	.765	1.031	.453	.531	.140
	192210278	HDC-2014-CC	2/0	BLACK	1/4	.278	1.953	.828	.828	.375	.578	.140
	192210105	HDC-20516-CC	2/0	BLACK	5/16	.340	1.953	.828	.828	.375	.578	.140
	192210106	HDC-2038-CC	2/0	BLACK	3/8	.400	2.203	.828	1.078	.453	.578	.140
	192210107	HDC-2012-CC	2/0	BLACK	1/2	.520	2.203	.828	1.078	.453	.578	.140
	192210108	HDC-3014-CC	3/0	ORANGE	1/4	.278	2.093	.906	.843	.375	.625	.140
	192210109	HDC-30516-CC	3/0	ORANGE	5/16	.340	2.093	.906	.843	.375	.625	.140
	192210110	HDC-3038-CC	3/0	ORANGE	3/8	.400	2.343	.906	1.093	.453	.625	.140
C	192210355	HDC-3012-CC	3/0	ORANGE	1/2	.520	2.343	.906	1.093	.453	.625	.140
	192210356	HDC-4014-CC	4/0	PURPLE	1/4	.278	2.250	1.015	.875	.375	.703	.156
	192210357	HDC-40516-CC	4/0	PURPLE	5/16	.340	2.250	1.015	.875	.375	.705	.156
	192210358	HDC-4038-CC	4/0	PURPLE	3/8	.400	2.500	1.015	1.125	.453	.703	.156
	192210359	HDC-4012-CC	4/0	PURPLE	1/2	.520	2.500	1.015	1.125	.453	.703	.156
	192210360	HDC-25038-CC	250MCM	YELLOW	3/8	.400	2.609	1.140	1.140	.500	.781	.187
	192210361	HDC-25012-CC	250MCM	YELLOW	1/2	.520	2.609	1.140	1.140	.500	.781	.187
	192210362	HDC-30038-CC	300MCM	WHITE	3/8	.400	2.734	1.218	1.140	.500	.843	.187
B	192210363	HDC-30012-CC	300MCM	WHITE	1/2	.520	2.796	1.218	1.203	.546	.843	.187
	192210364	HDC-30058-CC	300MCM	WHITE	5/8	.660	2.796	1.218	1.203	.546	.843	.187
	192210365	HDC-35012-CC	350MCM	RED	1/2	.520	2.984	1.312	1.250	.546	.906	.203
	192210366	HDC-35058-CC	350MCM	RED	5/8	.660	2.984	1.312	1.250	.546	.906	.203
	192210367	HDC-40012-CC	400MCM	BLUE	1/2	.520	3.093	1.578	1.281	.546	.968	.218
	192210368	HDC-40058-CC	400MCM	BLUE	5/8	.660	3.093	1.578	1.281	.546	.968	.218
	192210369	HDC-50012-CC	500MCM	BROWN	1/2	.520	3.453	1.578	1.296	.546	1.093	.250
A	192210370	HDC-50058-CC	500MCM	BROWN	5/8	.660	3.453	1.578	1.406	.546	1.093	.250

NOTES:  
1. MATERIAL: COPPER  
2. PLATING: TIN  
3. OTHER STUD SIZES MAY BE AVAILABLE, PLEASE CONSULT FACTORY.  
4. UL, CSA, AND WIRE GAUGE PRINTED ON TERMINAL.  
5. ALL DIMENSIONS ARE REFERENCE ONLY.

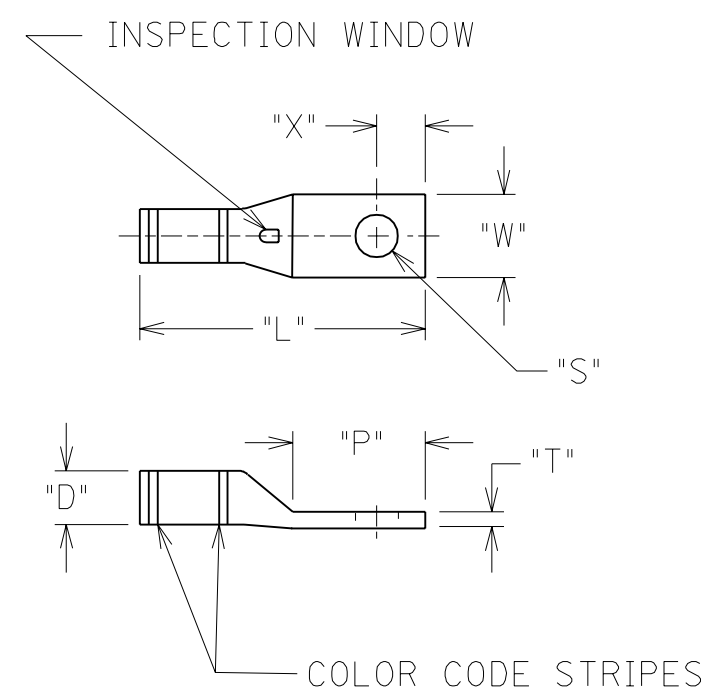

CUSTOMER DRAWING

A	RELEASE CUSTOMER DRAWING 05/11 ETC2000-0227 JH
LTR.	REVISIONS

DIMENSIONS SHOWN (METRIC) INCH		REVISE ONLY ON CAD SYSTEM													
UNLESS OTHERWISE SPECIFIED TOLERANCES: ANGULAR ± 1/2°		TITLE HEAVY DUTY COMPRESSION SITE HOLE TERMINALS STANDARD BARREL ONE HOLE													
<table border="1"> <thead> <tr> <th></th> <th>INCH</th> <th>METRIC</th> </tr> </thead> <tbody> <tr> <td>3 PLACE</td> <td>± ---</td> <td>± ---</td> </tr> <tr> <td>2 PLACE</td> <td>± ---</td> <td>± ---</td> </tr> <tr> <td>1 PLACE</td> <td>± ---</td> <td>± ---</td> </tr> </tbody> </table>			INCH	METRIC	3 PLACE	± ---	± ---	2 PLACE	± ---	± ---	1 PLACE	± ---	± ---	SHEET NO. DATE 94/02/14	
	INCH	METRIC													
3 PLACE	± ---	± ---													
2 PLACE	± ---	± ---													
1 PLACE	± ---	± ---													
DRAFT WHERE APPLICABLE MUST REMAIN WITHIN DIMENSIONS		PART NO. DRWG. NO. SEE CHART SD-19221-003													
DRWG. BY JH	CHK'D. BY RWD	FILE NAME 19221003 DGN	THIS DRAWING CONTAINS INFORMATION THAT IS PROPRIETARY TO MOLEX-ETC INC. AND SHOULD NOT BE USED WITHOUT WRITTEN PERMISSION.												
APP'D. BY RWD	SCALE NO:NE	DIV. B	SIZE B												