

## Molded, 25 mil Pitch, Dual-In-Line Thin Film Resistor, Surface Mount Network

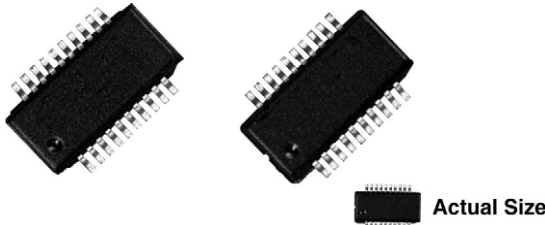

OSOP Series resistor networks feature a space saving 25 mil lead pitch versus the current 50 mil pitch standard. This allows users to reduce board space more than 50 % over current standards. The OSOP series features 16, 20, and 24 pin variations with isolated and last pin common schematics. Custom schematics and resistor values are also available, consult factory.

### SCHEMATIC

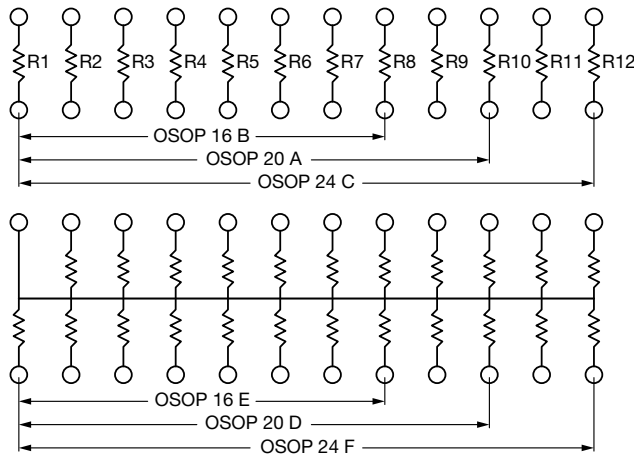

### FEATURES

- 0.068" (1.73 mm) maximum seated height
- Rugged molded case construction with no internal solder
- JEDEC® MO-137 variation AB = 16 pin, AD = 20 pin, AE = 24 pin
- Material categorization: for definitions of compliance please see [www.vishay.com/doc?99912](http://www.vishay.com/doc?99912)



**RoHS\***  
Available  
**HALOGEN FREE**

### Note

\* This datasheet provides information about parts that are RoHS-compliant and / or parts that are non RoHS-compliant. For example, parts with lead (Pb) terminations are not RoHS-compliant. Please see the information / tables in this datasheet for details

### TYPICAL PERFORMANCE

	ABSOLUTE	TRACKING
<b>TCR</b>	<b>25</b>	<b>5</b>
	ABSOLUTE	RATIO
<b>TOL.</b>	<b>0.1</b>	<b>0.05</b>

### STANDARD RESISTANCE OFFERING ( $R_1 =$ )

500 $\Omega$	10 k $\Omega$
1 k $\Omega$	20 k $\Omega$
2 k $\Omega$	50 k $\Omega$
5 k $\Omega$	100 k $\Omega$

### Note

- Consult factory for additional values and schematics

### STANDARD ELECTRICAL SPECIFICATIONS

TEST	SPECIFICATIONS	CONDITIONS
Material	Passivated nichrome	-
Pin / Lead Number	16, 20, 24	-
Resistance Range	500 $\Omega$ to 100 k $\Omega$ per resistor	-
TCR: Absolute	$\pm 25$ ppm/ $^{\circ}$ C	-55 $^{\circ}$ C to +125 $^{\circ}$ C
TCR: Tracking	$\pm 5$ ppm/ $^{\circ}$ C	-55 $^{\circ}$ C to +125 $^{\circ}$ C
Tolerance: Absolute	$\pm 0.1$ % to 1 %	+25 $^{\circ}$ C
Tolerance: Ratio	$\pm 0.025$ % to 0.5 %	+25 $^{\circ}$ C
Power Rating: Resistor	100 mW	Maximum at +70 $^{\circ}$ C
Power Rating: Package	400 mW	Maximum at +70 $^{\circ}$ C
Stability: Absolute	$\Delta R \pm 0.05$ %	2000 h at +70 $^{\circ}$ C
Stability: Ratio	$\Delta R \pm 0.015$ %	2000 h at +70 $^{\circ}$ C
Voltage Coefficient	< 0.1 ppm/V (typical)	-
Working Voltage	100 V max. not to exceed $\sqrt{P \times R}$	-
Operating Temperature Range	-55 $^{\circ}$ C to +125 $^{\circ}$ C	-
Storage Temperature Range	-55 $^{\circ}$ C to +150 $^{\circ}$ C	-
Noise	< -30 dB	-
Thermal EMF	0.08 $\mu$ V/ $^{\circ}$ C	-
Shelf Life Stability: Absolute	$\Delta R \pm 0.01$ %	1 year at +25 $^{\circ}$ C
Shelf Life Stability: Ratio	$\Delta R \pm 0.002$ %	1 year at +25 $^{\circ}$ C

DIMENSIONS AND IMPRINTING in inches and millimeters			
DIMENSION	INCHES	MILLIMETERS	
		A	16 pin
	20, 24 pin	0.341 ± 0.003	8.66
B		0.154	3.91
C		0.237	6.02
D		0.025	0.635
E		0.010 ± 0.002	0.25 ± 0.05
F		0.062	1.58
G		0.068	1.73
H		0.010 ± 0.002	0.25 ± 0.05
I		0.025	0.64
J	16 pin	0.009	0.23
	20 pin	0.057	1.47
	24 pin	0.057	1.47

MECHANICAL SPECIFICATIONS	
Resistive Element	Passivated nichrome
Substrate Material	Silicon
Body	Molded epoxy
Terminals	Copper alloy
Lead (Pb)-free Option	100 % matte tin
Tin Lead Option	Sn90
Tin Lead and Lead (Pb)-free Finish	Plated

GLOBAL PART NUMBER INFORMATION				
New Global Part Numbering: OSOPA1002B U F				
GLOBAL MODEL (4 or 5 digits)	SCHEMATIC	RESISTANCE	TOLERANCE AND RATIO TOLERANCE	PACKAGING
<b>OSOP</b> (Tin Lead)  <b>OSOPT</b> (Lead (Pb)-free) (e3)	<b>A</b> = 20 pin 10 isolated resistors <b>B</b> = 16 pin 8 isolated resistors <b>C</b> = 24 pin 12 isolated resistors  <b>D</b> = 20 pin 19 resistors pin 20 common <b>E</b> = 16 pin 15 resistors pin 16 common <b>F</b> = 24 pin 23 resistors pin 24 common	First 3 digits are significant figures and the last digit specifies the number of zeroes to follow.  Example: 1002 = 10K 1003 = 100K	Abs. Tol.      Ratio <b>A</b> = 0.1 % <sup>(1)</sup> 0.05 % <b>B</b> = 0.1 %        0.1 % <b>C</b> = 0.25 %      0.1 % <b>D</b> = 0.5 %        0.1 % <b>F</b> = 1 %            0.5 % <b>Z</b> = 0.1 % <sup>(1)</sup> 0.025 %	TAPE AND REEL <b>T0</b> = 100 min., 100 mult <b>T1</b> = 1000 min., 1000 mult <sup>(2)</sup> <b>T3</b> = 300 min., 300 mult <b>T5</b> = 500 min., 500 mult <b>TF</b> = Full reel 2500 <b>TS</b> = 100 min., 1 mult  <b>UF</b> = TUBED
Historical Part Number example: OSOPA5000B (for reference purposes only)				
OSOP	A	5000	B	
SERIES	SCHEMATIC	RESISTANCE	TOLERANCE AND RATIO TOLERANCE	

**Notes**

- (1) Tolerance available 1K and up  
 (2) Preferred packaging code