

7S Series

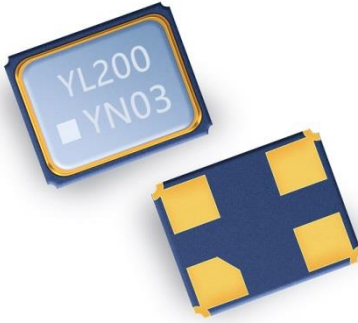

■ Features

- 7.0 x 5.0 x 1.2 MAX. mm of surface mounted quartz crystal units.
- Excellent reliability characteristics such as heat and mechanical shock.
- Pb-free and satisfy RoHs requirements.
- Reflow soldering is available.

■ Applications

Digital Electronics, Consumer Products, Mobile Communications, and Automotive

■ Specifications

Frequency range	6~100 MHz
Overtone Order	Fundamental, 3rd overtone
Frequency tolerance at 25°C	±10, ±15, ±20, ±30, ±50 ppm
Operating temperature range and frequency stability	See Table 1
Equivalent series resistance	See Table 2
Shunt capacitance	5 pF Max or specify
Load capacitance	Series, 8, 16, 20 pF or specify
Drive level (Max.)	10, 100, 200 μW or specify
Insulation resistance	500MΩ Min. at DC 100V
Aging at 25°C	±3 ppm / year Max
Storage temperature range	-40 ~ +85 °C or -40 ~ +125 °C
Measure instrument	S&A 250B system with PI circuit

■ Table 1: Operating temperature range and frequency stability

Temp	ppm				
	±5	±10	±15	±20	±50
0~+ 50 °C	●	●	●	●	●
- 10~+ 60 °C		●	●	●	●
- 20~+ 70 °C		●	●	●	●
- 30~+ 85 °C			●	●	●
- 40~+ 85 °C				●	●
- 40~+ 125 °C					●

■ Table 2: Equivalent series resistance

Frequency (MHz)	Overtone Order	ESR (Ω MAX)
6~10	Fundamental	100
10~12	Fundamental	60
12~15	Fundamental	50
15~54	Fundamental	40
40~100	3 rd overtone	90
100~150	3 rd overtone	80

The mark “●” denotes our achieved level

■ Dimensions (unit: mm)

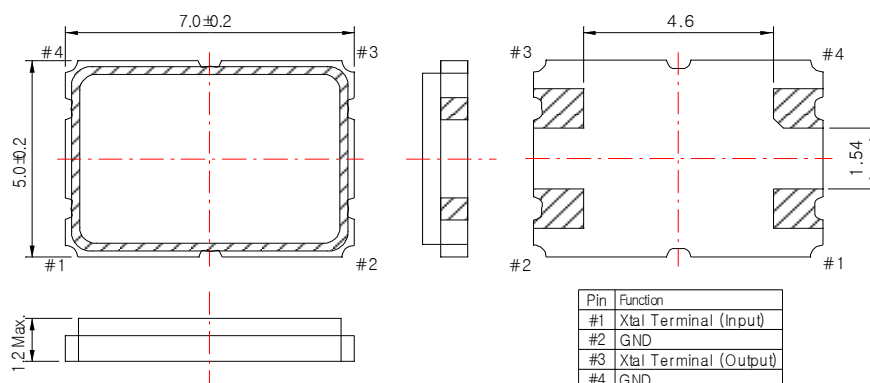

■ Land pattern (unit: mm)

