

REACH & RoHS  
COMPLIANT

REV.	ECN / DESCRIPTION	BY	DATE
A0	NEW	MQ.QU	2017.09.23
A1	MODIFY MODEL STRUCTURE	MQ.QU	2018.06.06

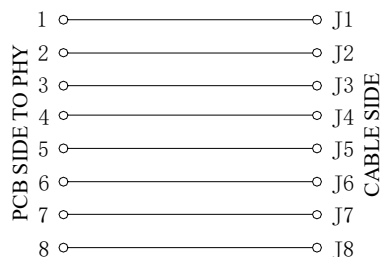
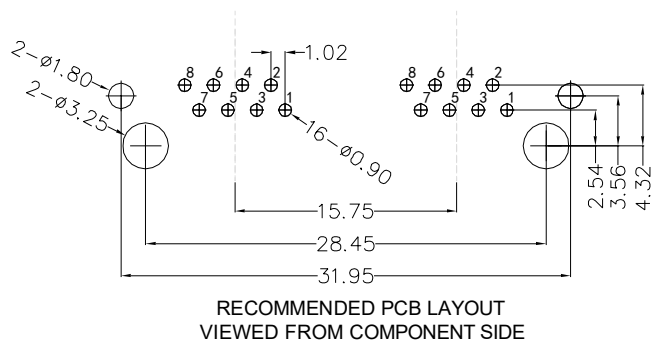
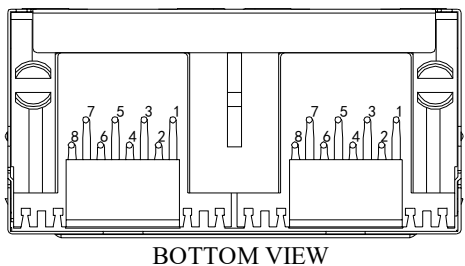
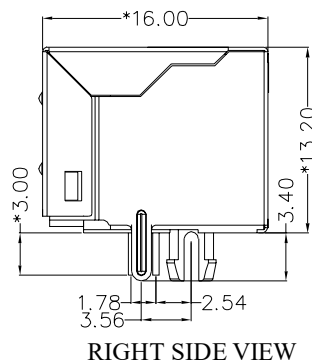
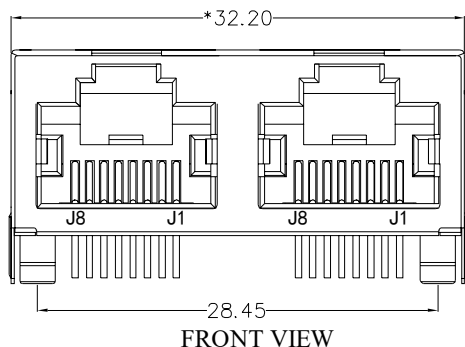

**MATERIAL:**

HOUSING: PA46,UL94V-0,BLACK.  
TERMINAL: PHOSPHOR BRONZE Ø=0.46MM, 0.6U" GOLD PLATING.  
SHIELD: C2680,T=0.20MM,20 MIN NICKEL PLATING  
ON ALL AREA.

**MACHANICAL:**

DURABILITY: 750 CYCLES MIN,12.5MM/MINUTE.  
INSERTION FORCE: 2.2KG.F MAX.  
RETENTION STRENGTH : 7.7KG.F BETWEEN JACK AND PLUG.  
OPERATING TEMPERATURE: -40°C~+85°C.  
STORAGE TEMPERATURE: -40°C~+85°C.  
ALL CRITICAL DIMENSIONS WITH "\*"

**ELECTRICAL:**

VOLTAGE: 125 VOLTS AC.  
CURRENT RATING : 1.5AMP.  
DIELECTRIC STRENGTH: 1000 VAC RMS 50HZ OR 60HZ,1MIN.  
INSULATION RESISTANCE: 500 MEGA OHMS MIN. INITIAL  
AFTER 500V DC FOR 1 MINUTE.  
CONTACT RESISTANCE: SINGLE TERMINAL 30 MILLIOHMS MAX.  
INITIAL 50 MILLIOHMS MAX. AFTER  
DURABILITY TEST.

深圳市威尔杰电子有限公司

TITLE: RJ45 1*2 56带屏蔽	SIZE A4	UNITS MM[INCH]	APPROVED BY: JP.Gong	
PART NO.: 561288GWA3DY1027	SACLE 1:1	REV A1	x±0.35 .x±0.30	x°±3.0° .x°±2.0°
REMARK:	SHEET 1/1		.xx±0.25 .xxx±0.10	.xx°±1.5° .xxx°±1.0°
			DESIGND BY: MQ.Qu	