

FXC0420 Series



Introduction

- 100% Lead(Pb)-Free and RoHS compliant.
- High current, low DCR, high efficiency.
- 4.75×4.45×2.0mm maximum surface mount package .
- Operating temperature -40℃~+125℃ (Including self - temperature rise) .



Applications

- Note PC power system .
- DC/DC converter .

Product Identification

FXC 0420 --1R5 M
① ② ③ ④

- ① FXC ----- Series name
- ② 0420----- Dimension
- ③ 1R5 ----- Inductance Value (1R5 = 1.5μH)
- ④ M -----Inductance Tolerance (M= ± 20%)

Dimensions (unit:mm)

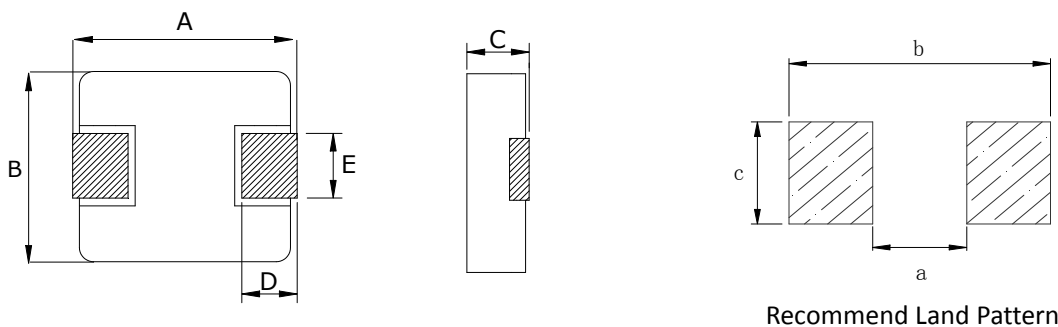

A	B	C	D	E	a typ	b typ	c typ
4.4±0.35	4.2±0.25	1.8±0.2	0.8±0.3	2.0±0.3	2.2	5.2	2.5

Marking

The inductor is marked with a 3-digit code

Nominal Inductance	
Example	Nominal Value
1R0	1.0 μH
100	10 μH
101	100 μH

Note : Using Ink for marking



Structure and Components

Symbol	Components	Material
a	MARKING	Ink(black)
b	CORE	Carbonyl Powder
c	WIRE	Polyester Wire or equivalent.
d	Terminal	Copper plated with Sn

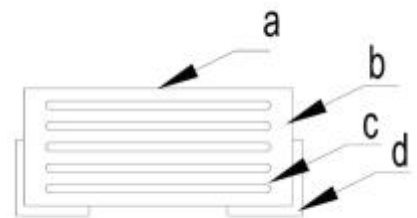

Part No.	Inductance	DC Resistance	Saturation Current	Heating Rating Current
	L0 (μH)	DCR (mΩ)	Isat (A)	Irms (A)
	±20 %, 100 kHz, 1V	MAX.	TYP.	TYP.
FXC0420-R33M	0.33	8.6	18	10
FXC0420-R47M	0.47	14	12	8
FXC0420-R68M	0.68	19	10	7
FXC0420-1R0M	1.0	27	8.5	5
FXC0420-1R5M	1.5	42	7	4.5
FXC0420-2R2M	2.2	61	6	4
FXC0420-3R3M	3.3	76	4	3.5
FXC0420-4R7M	4.7	105	3.5	2.6
FXC0420-6R8M	6.8	172	2.8	2.1
FXC0420-100M	10	243	2.3	1.8

Notes

1. All test data is referenced to 25 °C ambient
2. I_{rms} (A):DC current (A) that will cause an approximate ΔT of 40 °C(reference ambient temperature is 25 °C)
3. I_{sat}(A):DC current (A) that will cause L0 to drop approximately **30 %**
4. The part temperature (ambient + temp rise) should not exceed 125 °C under worst case operating conditions. Circuit design, component placement, PWB trace size and thickness, airflow and other cooling provisions all affect the part temperature. Part temperature should be verified in the end application.

Mechanical Reliability		
Item	Specification and Requirement	Test Method
Solderability	1. No case deformation or change in appearance 2. New solder coverage More than 95%	1.Preheat: 155℃±5℃ , 60S±2S 2.Tin: lead-free. 3.Temperature:240℃±5℃, flux 3.0S±0.5S.
Mechanical shock	1. No case deformation or change in appearance 2. $\Delta L/L_0 \leq \pm 10\%$	1. Acceleration: 100G 2. Pulse time: 6ms 3. 3 times in each positive and negative direction of 3 mutual perpendicular directions
Mechanical vibration	1. No case deformation or change in appearance 2. $\Delta L/L_0 \leq \pm 10\%$	1. Reflow: 2times 2. Frequency: 10HZ~55HZ~10HZ, 20 Min/Cycles 3. Amplitude: 1.52 mm 4. Directions: X,Y,Z 5. Time: 12 cycle / direction
Endurance Reliability		
Item	Specification and Requirement	Test Method
Thermal Shock	Inductance change: Within $\pm 10\%$ Without distinct damage in appearance	1. First -40℃ for 30 minutes, last 125℃ for 30 minutes as 1 cycle. Go through 1000 cycles. 2. Max transfer time is 3 minutes. 3. Measured at room temperature after placing for 24±2 hours
Humidity Resistance	Inductance change: Within $\pm 10\%$ Without distinct damage in appearance	1.Reflow 2 times, 2.85℃,85%RH,1000 hours 3.Measured at room temperature after placing for 24±2 hours
Low temperature storage	Inductance change: Within $\pm 10\%$ Without distinct damage in appearance	1. Temperature: -40 ± 2℃ 2. Time: 1000 hours 3. Measured at room temperature after placing for 24±2 hours
High temperature storage	Inductance change: Within $\pm 10\%$ Without distinct damage in appearance	1. Temperature: +125 ± 2℃ 2. Time: 1000 hours 3. Measured at room temperature after placing for 24±2 hours

Recommended Soldering Technologies

(1) Re-flowing Profile

Preheat condition: 150 ~200°C/60~180sec.

Allowed time above 217°C: 80~120sec.

Max temp: 260°C

Max time at max temp: 10 sec.

Solder paste: Sn/3.0Ag/0.5Cu

Allowed Reflow time: 2x max

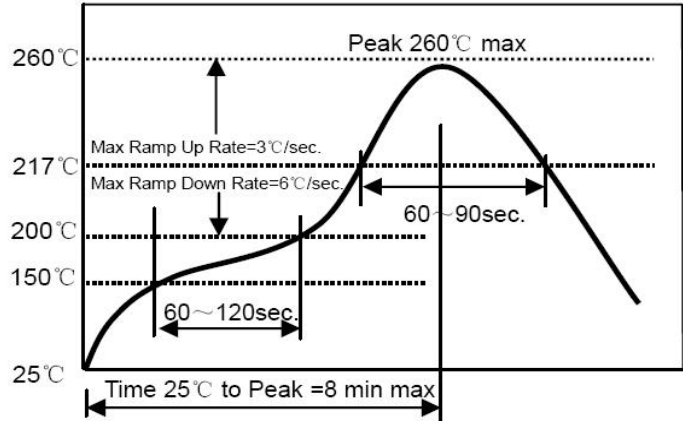

(2) Iron Soldering Profile

Iron soldering power: Max. 30W

Pre-heating: 150°C/60sec.

Soldering Tip temperature: 350°C Max.

Soldering time: 3sec. Max.

Solder paste: Sn/3.0Ag/0.5Cu

Max.1 times for iron soldering

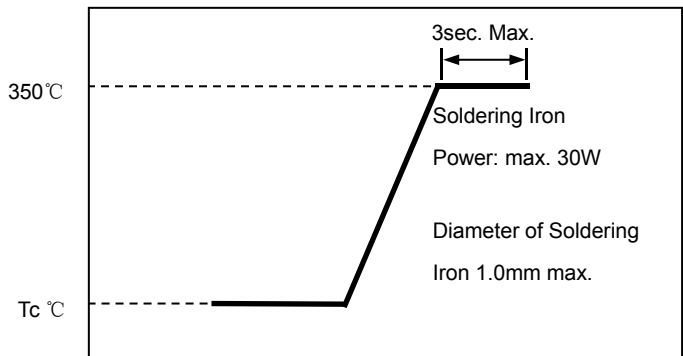

Packaging Information

(1) Tape Packaging Dimensions (Unit: mm)

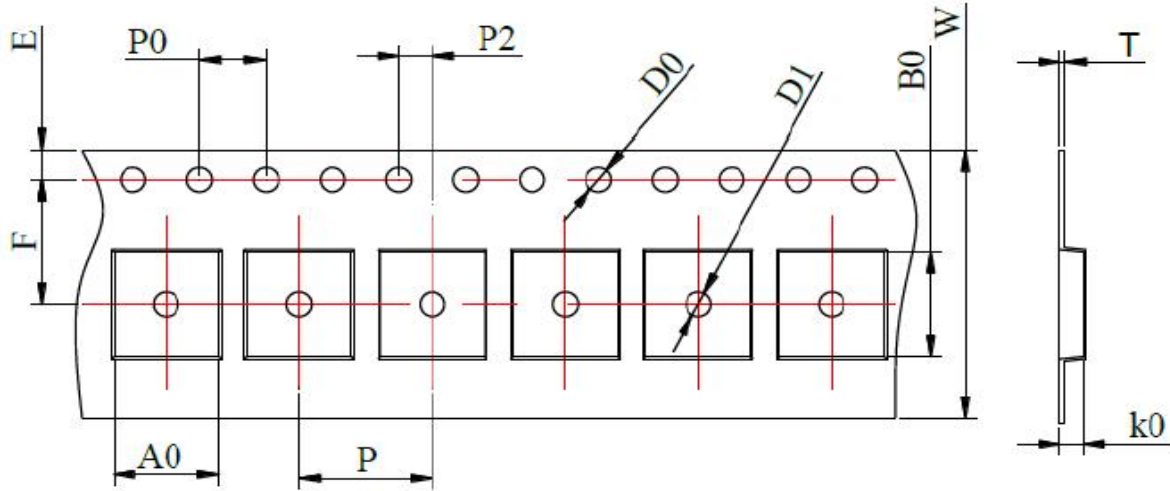

Tape dimensions (mm)											
W	P	P0	P2	D0	D1	T	A0	B0	K0	E	F
12	8	4	2	1.5	1.5	0.35	4.5	4.85	2.3	1.75	5.5
±0.3	±0.1	±0.1	±0.1	±0.1	±0.1	±0.05	±0.1	±0.1	±0.1	±0.1	±0.1

Taping Drawings (UNIT:mm)

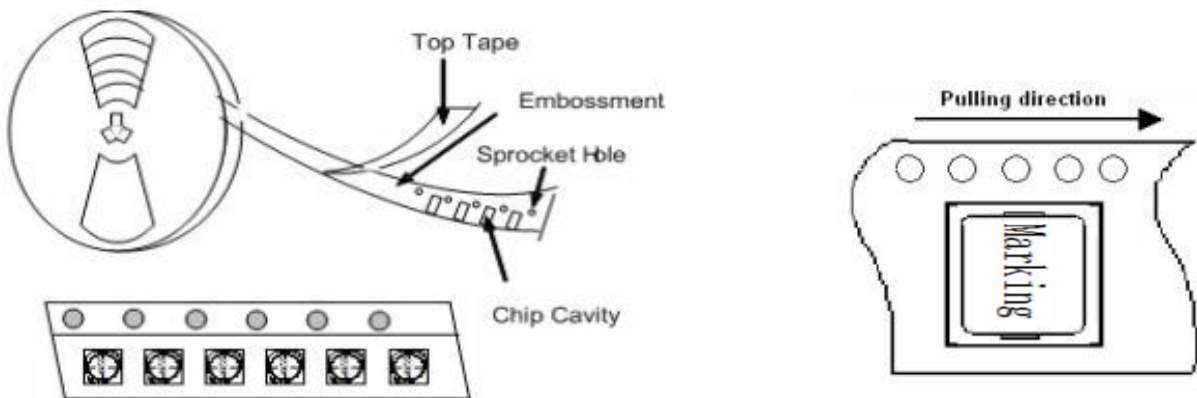

(2) Reel Dimensions (Unit: mm)

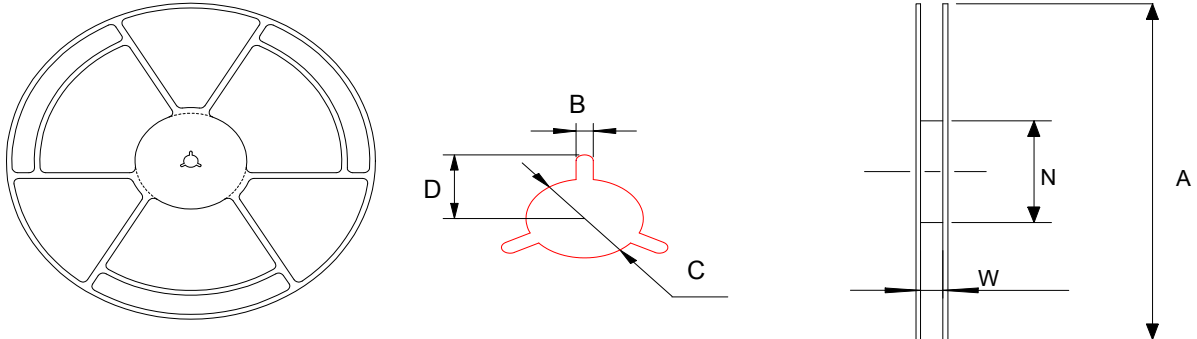

A	W	N	B	C	D
330±2.0	12.8±0.2	97±0.5	2.2±0.5	13.0±0.2	10.75±0.25

(3) Packaging Quantity(PCS)

Type	Standard Quantity		
	Reel	Inner box	Carton box
FXC0420	3000 pcs / reel	4Reel / box (12000 pcs)	4 Middle boxes, (48,000 pcs)

(4) Peel force of top cover tape

The peel speed shall be about 300mm/minute

The peel force of top cover tape shall be between 0.1 to 1.3 N

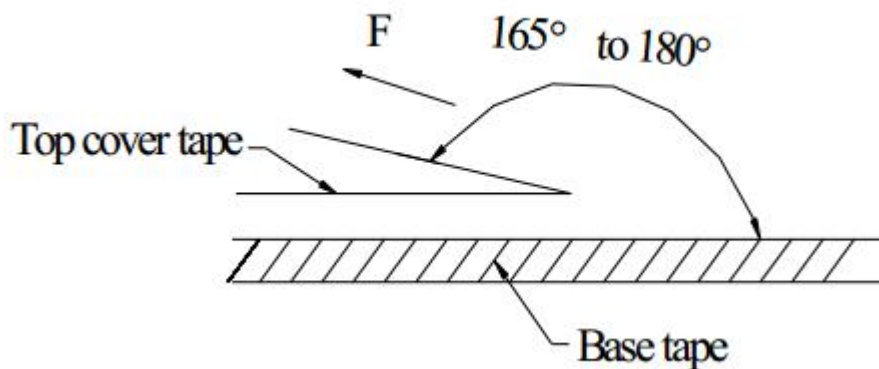

(5) Reel Label

Label on the reel

- Customer's part Number
- Lot Number
- Quantity
- date code

Shipping Label

- Customer's part Number
- Manufacturer's part Number
- Quantity
- date code

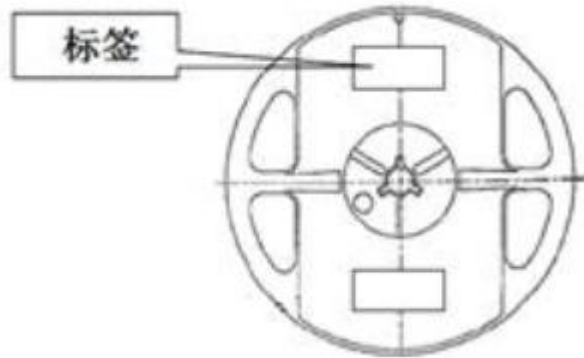

(6) Inner Box

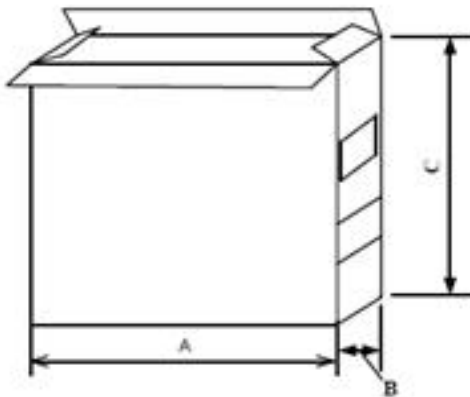

Packaging type	A (mm)	B (mm)	C (mm)
Inner box	335	70	340

(7) Carton

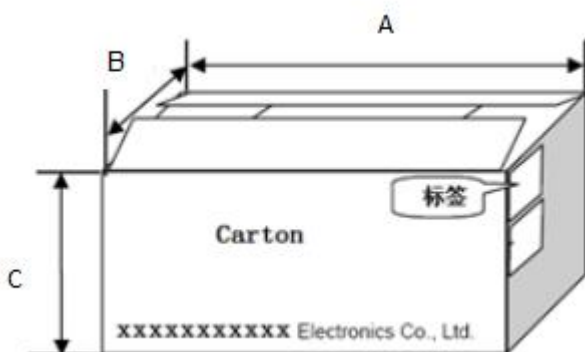

Packaging type	A (mm)	B (mm)	C (mm)
type	360	360	360