

SKG123N规格书

L1+L5双频定位模块

SKG123N Datasheet

L1+L5 Dual-band Positioning Module

文档信息/Document information

| | |
|-----------------------------|--|
| 标题/Title | SKG123N 双频组合导航模块规格书 |
| | SKG123N L1+L5 Dual-band Positioning Module Datasheet |
| 文档类型/Document type | 规格书/Datasheet |
| 文档编号/Document number | SL-22100297 |
| 修订和日期/Revision and date | V1.01 10-Oct-2022 |
| 公开限制/Disclosure restriction | 外部公开/External public |

版本历史/Revision History

| 版本/Version | 描述/Description | 制定/Make | 日期/Date |
|------------|----------------------|---------|----------|
| V1.01 | 初始版本/Initial version | Bennett | 20221010 |

SKYLAB 保留本文档及本文档所包含的信息的所有权利。SKYLAB 拥有本文档所述的产品、名称、标识和设计的全部知识产权。严禁没有征得 SKYLAB 的许可的情况下复制、使用、修改或向第三方披露本文档的全部或部分内容。

SKYLAB 对本文档所包含的信息的使用不承担任何责任。没有明示或暗示的保证，包括但不限于关于信息的准确性、正确性、可靠性和适用性。SKYLAB 可以随时修订这个文档。可以访问 www.skylab.com.cn 获得最新的文件。

Copyright © 2022, 深圳市天工测控技术有限公司。

SKYLAB® 是深圳市天工测控技术有限公司在中国的注册商标。

SKYLAB reserves all rights to this document and the information contained herein. Products, names, logos and designs described herein may in whole or in part be subject to intellectual property rights. Reproduction, use, modification or disclosure to third parties of this document or any part thereof without the express permission of SKYLAB is strictly prohibited.

The information contained herein is provided "as is" and SKYLAB assumes no liability for the use of the information. No warranty, either express or implied, is given, including but not limited, with respect to the accuracy, correctness, reliability and fitness for a particular purpose of the information. This document may be revised by SKYLAB at any time. For most recent documents, visit www.skylab.com.cn.

Copyright © 2022, Skylab M&C Technology Co., Ltd.

SKYLAB® is a registered trademark of Skylab M&C Technology Co., Ltd in China

目录/Contents

| | |
|--|----|
| 1 产品简介/Product Introduction | 4 |
| 2 典型应用/Application | 4 |
| 3 产品特点/Features | 4 |
| 5 传输及外设接口/Transmission and peripheral interface | 5 |
| 5.1 PPS | 5 |
| 5.2 UART | 5 |
| 5.3 通信频率/Frequency of communication | 5 |
| 5.4 通信协议/Communication protocol | 5 |
| 5.5 控制命令/Control command | 6 |
| 6 电气特性/Electrical specification | 6 |
| 7 性能指标/Performance evaluation | 7 |
| 8 管脚定义/PIN Definition | 9 |
| 9 管脚描述/Pin description | 9 |
| 10 机械尺寸/Machine Dimension | 11 |
| 11 参考电路/Reference circuit | 12 |
| 12 软件说明/ Software description | 12 |
| 12.1 NMEA 0183 协议/ The NMEA 0183 protocol is available | 12 |
| 12.2 GGA-定位数据信息/GGA- Location information | 13 |
| 12.3 GSA-当前卫星信息/GSA- GNSS satellites in using | 14 |
| 12.4 GSV-可见卫星信息//GSV- GNSS Satellites in View | 15 |
| 12.5 RMC-推荐定位信息/ RMC- Recommended locating information | 16 |
| 12.6 GLL-地理定位信息/Geographic Position – Latitude/Longitude | 17 |
| 12.7 VTG-地面速度信息/VTG- Course Over Ground and Ground Speed | 18 |
| 12.8 ZDA-时间日期信息/ ZDA- Date and Time | 19 |
| 13 联系方式/ Contact Information | 19 |

1 产品简介/Product Introduction

SKG123N 是一款高性能的面向车载导航领域的车载组合导航模块，模块能够同时支持 GPS、BDS、GLONASS、Galileo 以及 QZSS 的卫星定位系统、并且支持 L1+L5 双频定位。

SKG123N is a high-performance vehicle integrated navigation module for the field of vehicle navigation. The module can simultaneously support GPS, BDS, GLONASS, Galileo and QZSS satellite positioning systems, and support L1+L5 dual frequency positioning.



图 1: SKG123N 正视图/Top view

2 典型应用/Application

- ◆ 汽车导航/ Auto navigation
- ◆ 个人导航设备/ Personal navigation equipment
- ◆ 车辆远程监控/Remote vehicle monitoring

3 产品特点/Features

- ◆ L1 支持 GPS, GLO, GAL, BDS, QZSS 系统/ L1 supports GPS, GLO, GAL, BDS, QZSS systems
- ◆ L5 支持 GPS, GAL, BDS, QZSS/ L5 supports GPS, GAL, BDS, and QZSS
- ◆ 支持 SBAS(WAAS, EGNOS, MSAS, GAGAN)/ Support SBAS(WAAS, EGNOS, MSAS, GAGAN)
- ◆ 支持 RTCM(v2.3 和 v3.3)/ Support RTCM(v2.3 和 v3.3)
- ◆ 标准通信协议 NEMA0183/Plug and play standard communication protocol NEMA0183
- ◆ 支持 AGPS: EPO, EASY, NVRAM, hotstill/ Support AGPS: EPO, EASY, NVRAM, hotstill

◆ 弱信号下具有较好的定位精度和位置有效性/ It has better positioning accuracy and location effectiveness under weak signals

◆ 符合 RoHS, FCC, CE /Compliance with RoHS, FCC, CE

5 传输及外设接口/Transmission and peripheral interface

5.1 PPS

秒脉冲（PPS）：SKG123 提供非常精准的时间脉冲 PPS 信号，PPS 信号可为外部系统提供授时功能，脉冲宽度可调，精度 15ns 每 24h，默认情况下每秒输出一个脉冲。

Second pulse (PPS): The SKG123 provides a very accurate time pulse PPS signal, the PPS signal can provide the timing function for the external system, the pulse width is adjustable, the accuracy is 15ns every 24h, by default, it output a pulse per second.

5.2 UART

SKG123N 模块提供了两个串口，其中，UART0 用于发送卫星信息和接收差分信息，UART2 用于输入、输出差分信息。支持数据传输、固件升级功能，输入/输出信号类型为 LVTTTL 电平。默认波特率为 115200bps，最高可设为 921600bps，串口波特率均可由用户自行配置。

The SKG123N module provides two serial ports. Serial UART0 is used to send satellite information and receive differential information, and serial port 2 is used to input and output differential information. Support data transmission, firmware upgrade function, input / output signal type is LVTTTL level. The default port rate is 115200bps, which can be set up to 921600bps, and the serial port port rate can be configured by the user.

5.3 通信频率/Frequency of communication

目前，系统支持输出 1hz 和 10hz 的数据刷新频率，默认频率为 1HZ。

Currently, the system supports the output data refresh frequency of 1hz and 10hz. The default frequency is 1hz.

5.4 通信协议/Communication protocol

目前，SKG123N 模块输出常见的 NMEA0183 协议，例如：GPGGA、GPRMC，GPGSV, GPGSA。

At present, THE SKG123N module outputs common NMEA0183 protocols, such as GPGGA, GPRMC, GPGSV and GPGSA.

5.5 控制命令/Control command

SKG123N 系统支持用户通过串口发控制命令实现如下功能，但是，SKG123N 无法保存设置，即 SKG123N 每次上电都是按默认方式输出。

The SKG123N system supports the following functions by sending control commands through the serial port. However, the SKG123N cannot save the Settings. That is, the SKG123N output the default mode every time it is powered on.

6 电气特性/Electrical specification

◆ 极限参数/limit Parameter

| 参数/Parameter | 符号/Symbol | 最小值/Min. | 最大值/Max. | 单位/Unit |
|--------------------------|-----------|----------|----------|---------|
| 电源/power supply | | | | |
| 供电电压/Supply Voltage | VCC | -0.3 | 3.6 | V |
| 输入输出/ IO | | | | |
| I/O 特性/I/O Features | VIO | -0.3 | 3.6 | V |
| RF 输入功率/RF Input power | RF_IN | | 0 | dBm |
| 静电保护/ESD | RF_IN | | 2000 | V |
| 环境/Environment | | | | |
| 存储温度/Storage temperature | Tstg | -40 | 85 | ° C |
| 湿度/Humidity | | | 95 | % |

◆ 电气特性/Electrical specification

| 参数/Parameter | 符号/Symbol | 条件/Condition | 最小值/Min. | 典型值/Type | 最大值/Max. | 单位/Unit |
|-------------------------|-----------|--------------|----------|----------|----------|---------|
| 电源电压/Supply voltage | VCC | | 3.0 | 3.3 | 3.6 | V |
| 电源电压/Supply voltage | V_BCKP | | 1.4 | 3.0 | 3.6 | V |
| 输入高压/input high voltage | VIH | | 2.4 | | 3.6 | V |
| 输入低压/input | VIL | | 0 | | 0.6 | V |

| | | | | | | |
|-----------------------------------|------|---------|-----|--|-----|----|
| low voltage | | | | | | |
| 输出高压/output high voltage | VOH | Ioh=4mA | 2.8 | | | V |
| 输出低压/output low voltage | VOL | Iol=4mA | | | 0.4 | V |
| 工作温度 /Operating temperature | Topr | | -40 | | 85 | °C |

注：本产品内部有复杂的组合导航算法，所以功耗比一般的导航模块高，请在设计硬件电路过程中，一定给本产品预留足够的功耗，即电流不小于 150mA。

Note: This product has a complex integrated navigation algorithm, so the power consumption is higher than that of ordinary navigation modules. Please reserve enough power consumption for this product during the design of hardware circuit, that is, the current is not less than 150mA.

7 性能指标/Performance evaluation

◆ 电气特性一倍标准差 (1 σ) 无里程计时/Electrical characteristics one standard deviation (1 σ) no mileage timing

| GNSS 信号丢失时间/Time of GNSS signal loss | 接收机定位方式/Receiver positioning mode | 水平位置 ¹ /Horizontal position 1 | 水平速度 ¹ /Horizontal velocity 1 | 俯仰横滚 ¹ /Pitch roll Angle 1 | 航向角 ¹ /Course Angle 1 |
|--------------------------------------|-----------------------------------|---|---|--|-------------------------------------|
| 5 秒/5 seconds | 标准定位/Standard setting | 2.0-3.5m | 0.05m/s | 0.5deg | 1.0deg |
| 10 秒/10 seconds | 标准定位/Standard setting | 10.0m | N/A | N/A | N/A |
| 60 秒/60 seconds | 标准定位/Standard setting | 25.0m | N/A | N/A | N/A |
| 120 秒/120 seconds | 标准定位/Standard setting | 60.0m | 0.5m/s | 1.0deg | 2.0deg |

◆ 电气特性一倍标准差 (1 σ) GNSS 部分功能/Electrical characteristics one standard deviation (1 σ) GNSS partial function

| 参数/Parameter | 描述/Description | |
|---------------------|----------------|--------------------------------------|
| 接收机类型/Receiver type | L1 | 1602 MHz GLONASS L1OF |
| | | 1575.42 MHz GPS L1CA QZSS L1CA |

| | | | |
|---|----------------------------------|--------------|--|
| | | | SBAS L1 QZSS L1 SAIF Galileo E1 (E1B+E1C) |
| | | 1561.098 MHz | BeiDou B1I |
| | L5 | 1176.45 MHz | GPS L5 QZSS L5 Galileo E5a BeiDou B2a |
| 首次定位时间 TTFF | 冷启动/Cold Start≤28s | | |
| | 热启动/Hot Start≤1s | | |
| | 辅助启动/Auxiliary start≤5s | | |
| 灵敏度/Sensitivity | 跟踪/Tracking: -165dBm | | |
| | 捕获/Acquisition: -160dBm | | |
| | 冷启动/Cold Start: -148dBm | | |
| | 温启/Warm Start: -148dBm | | |
| | 热启动/Hot Start: -156dBm | | |
| 水平定位精度/Horizontal positioning precision | 自主定位/Autonomous positioning≤1.2m | | |
| | SBAS≤1m | | |
| 授时精度/Timing precision | RMS≤30ns | | |
| | 99%≤60ns | | |
| 速度精度/Speed precision | 0.05m/s | | |
| 工作环境/Operational constraint | 动态/Dynamic≤4g | | |
| | 高度/Altitude≤50,000m | | |
| | 速度/Speed≤500m/s | | |

8 管脚定义/PIN Definition

| | | | |
|----------------------------|------------|-----------|----|
| 1 | SCL | GND | 24 |
| 2 | SDA | VCC_IN | 23 |
| 3 | GPIO10 | VBAT_VRTC | 22 |
| 4 | RTC_WACKUP | UART0_RXD | 21 |
| 5 | UART2_RTS | UART0_TXD | 20 |
| 6 | UART2_CTS | UART2_RXD | 19 |
| 7 | VIO18 | UART2_TXD | 18 |
| SKG123N Top view | | | |
| 8 | CHIP_EN | UART1_RXD | 17 |
| 9 | VCC_RF | UART1_TXD | 16 |
| 10 | GND | GPIO26 | 15 |
| 11 | RF_IN | LNA_EN | 14 |
| 12 | GND | GND | 13 |

图 3: SKG123N 管脚定义/pin definitions

9 管脚描述/Pin description

| 管脚编号 /Pin No. | 管脚定义/Pin name | I/O | 使用说明/Description | 备注/Remark |
|------------------|------------------|-----|--|-----------|
| 1 | SCL | | 悬空/Hanger | |
| 2 | SDA | | 悬空/Hanger | |
| 3 | GPIO10 | O | PPS 秒脉冲信号输出/Second pulse signal output | |
| 4 | RTC_WACKUP | I | 中断脚，低电平使能模块进入休眠状态 /Interrupt pin. Low level enables the | |
| 5 | UART2_RTS | | 悬空/Hanger | |
| 6 | UART2_CTS | I | 测试引脚，悬空/Test pin, hanger | 悬空/Hanger |

| | | | | |
|----|-----------|------|--|------------------------------------|
| 7 | VIO18 | 0 | 测试引脚, 悬空/Test pin, hanger | 悬空/Hanger |
| 8 | CHIP_EN | | 模块复位, 低电平有效/Module reset, active low | 不用时, 悬空/When not in use, hanger |
| 9 | VCC_RF | Pout | 有源天线供电端输出/Active antenna power output | |
| 10 | GND | G | 电源地/Ground | |
| 11 | RF_IN | I | GNSS 天线接口 | |
| 12 | GND | G | 电源地/Ground | |
| 13 | GND | G | 电源地/Ground | |
| 14 | LNA_EN | | 悬空/Hanger | |
| 15 | GPIO26 | | 接电源地 | |
| 16 | UART1_TXD | | 必须悬空/Must be hung up | |
| 17 | UART1_RXD | | 必须悬空/Must be hung up | |
| 18 | UART2_TXD | O | 备用串口发送/Standby serial port transmission | 备用/Standby application |
| 19 | UART2_RXD | I | 备用串口接收/Standby serial port reception | 备用/Standby application |
| 20 | UART0_TXD | O | 串口发送/Serial port to send | |
| 21 | UART0_RXD | I | 串口接收/Serial port to receive | |
| 22 | VBAT_VRTC | | 备份电池/Backup battery: 1.4V--3.6V | 不用时, 悬空/When |
| 23 | VCC_IN | Pin | 工作电压/Operating voltage: 3.0-3.6V | |
| 24 | GND | G | 电源地/Ground | |

10 机械尺寸/Machine Dimension

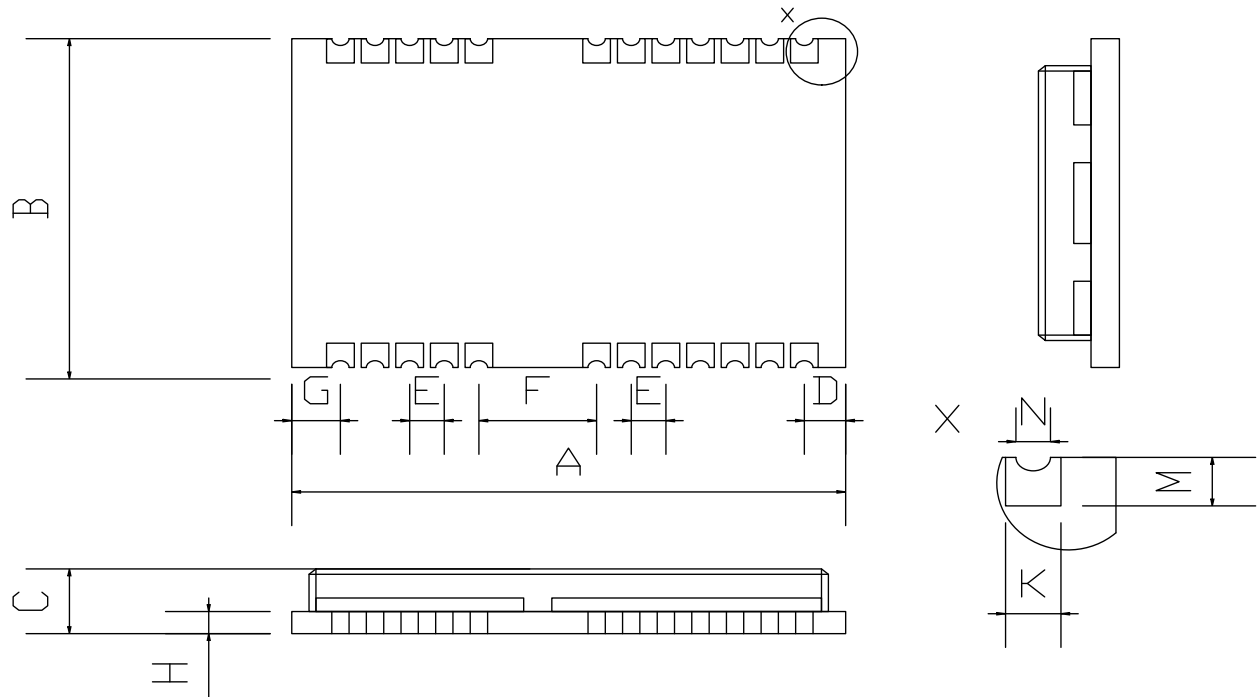

| Symbol | Min.(mm) | Type(mm) | Max.(mm) |
|--------|----------|----------|----------|
| A | 15.9 | 16.0 | 16.6 |
| B | 12.1 | 12.2 | 12.3 |
| C | 2.2 | 2.4 | 2.6 |
| D | 0.9 | 1.0 | 1.3 |
| E | 1.0 | 1.1 | 1.2 |
| F | 2.9 | 3.0 | 3.1 |
| G | 0.9 | 1.0 | 1.3 |
| H | | 0.82 | |
| M | 0.7 | 0.8 | 0.9 |
| N | 0.8 | 0.9 | 1.0 |
| K | 0.4 | 0.5 | 0.6 |
| Weight | 1.6g | | |

图 4: SKG123N 机械尺寸/Machine Dimension

11 参考电路/Reference circuit



图 5: SKG123N 参考电路//Reference circuit

12 软件说明/ Software description

12.1 NMEA 0183 协议/ The NMEA 0183 protocol is available

表 1-1 NMEA-0183 输出信息/ Table 1-1 NMEA-0183 Output information

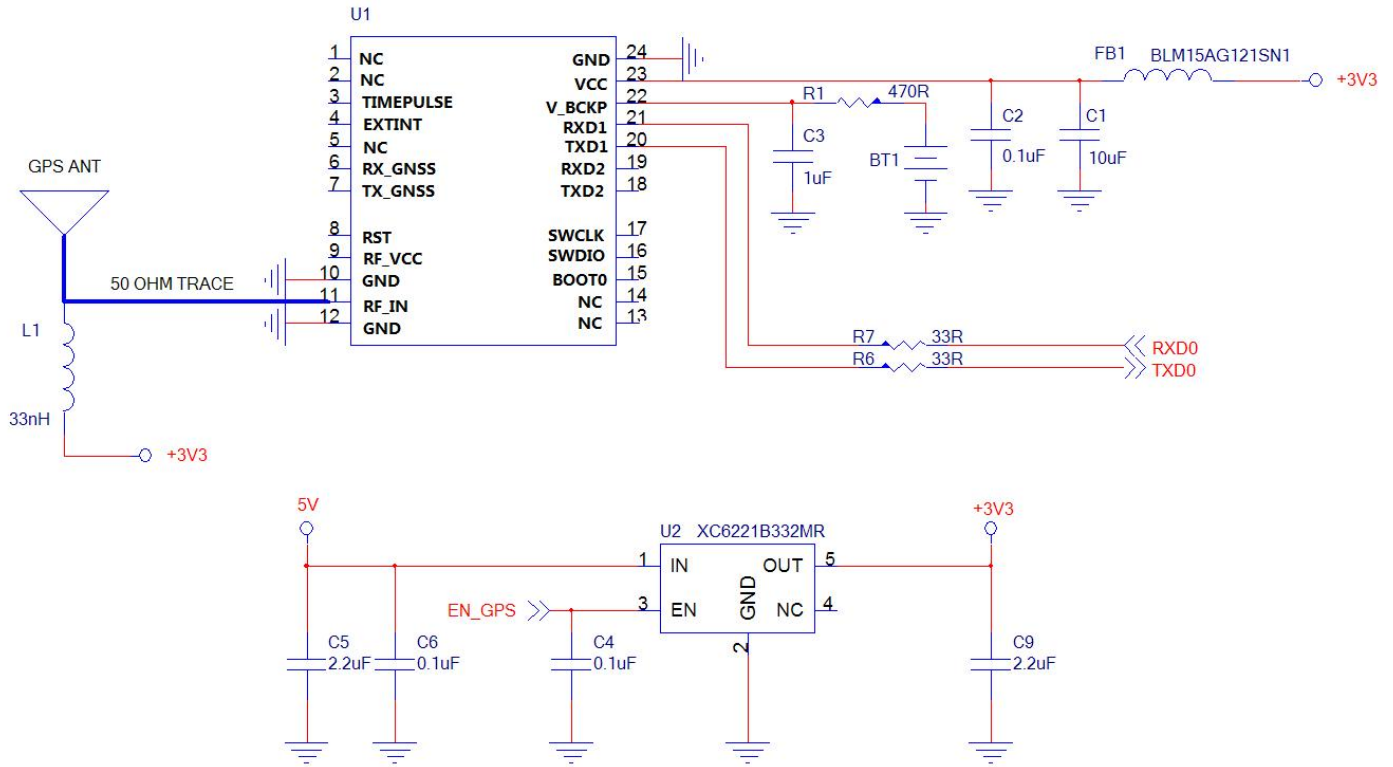
| NMEA 协议/NMEA protocol | 描述/Description | 默认/Default |
|-----------------------|---|------------|
| GGA | 定位数据信息/ Global positioning system fixed data | 打开/Y |
| GSA | 当前卫星信息/ DOP and active satellites | 打开/Y |
| GSV | 可见卫星信息/ Satellites in view | 打开/Y |
| RMC | 推荐定位信息/Recommended minimum specific data | 打开/Y |
| GLL | 大地坐标信息/Geographic position—latitude/longitude | 打开/Y |
| VTG | 地面速度信息/ Course over ground and ground speed | 打开/Y |
| ZDA | 当前时间(UTC1)信息/Date and Time | 打开/Y |

表 1-2 标识符助记码/Identifier mnemonic code

| 标识符/Identifier | 数据类型/ Data type |
|----------------|--------------------------|
| GB | 北斗模式/ Beidou mode |
| GP | GPS 模式/ GPS mode |
| GN | GNSS 模式/ GNSS mode |
| GA | Galileo 模式/ Galileo mode |
| GL | GLONASS 模式/ GLONASS mode |

12.2 GGA-定位数据信息/GGA- Location information

此语句包含定位位置、定位时间、定位精度。

Contains the location, time, and precision factor of navigation positioning.

\$GNGGA,022326.000,2238.3443,N,11403.0962,E,1,22,0.72,104.0,M,-2.2,M,,*69

表 2-1 GGA 语句格式/GGA Data Format

| 名称/Name | 举例/Example | 单位/Units | 描述/Description |
|--|------------|----------|--------------------------------------|
| 语句 ID/Message ID | \$GNGGA | | 表明语句为 GGA 信息/ GGA protocol header |
| UTC 时间/UTC Position | 022326.000 | | hhmmss.sss 时分秒格式/Time seconds format |
| 纬度/ Latitude | 2238.3443 | | ddmm.mmmm 度分格式/Degree split format |
| 纬度 N/S / N/S indicator | N | | N=北纬 S=南纬/ N= north S= South |
| 经度/ Longitude | 11403.0962 | | dddmm.mmmm 度分格式/Degree split format |
| 经度 E/W / E/W Indicator | E | | E=东经 W=西经/ N=north or S=south |
| 定位状态/ Position Fix Indicator | 1 | | 见附表 2-2/ See Table 2-2 |
| 已使用卫星数量 /Satellites Used | 22 | | 范围 0 到 24/ Range 0 to 12 |
| HDOP 水平精度因子 | 0.72 | | |
| 海拔高度/MSL Altitude | 104.0 | 米/M | |
| 单位/Unit | M | | |
| 大地水准面高度/ Geoidal height | -2.2 | | |
| 水准面划分单位/Level surface division unit | M | 米/M | |
| 校验值/ Checksum | *69 | | |

| | | |
|-----|-----------|-----------------------------------|
| EOL | <CR> <LF> | 结束标志符/ End of message termination |
|-----|-----------|-----------------------------------|

表 2-2 定位状态描述/ Position Fix Indicators

| 数值/Value | 描述//Description |
|----------|--|
| 0 | 未定位或定位信息不可用/ Unpositioned or positioned information is not available |
| 1 | SPS 模式/ SPS model |
| 2 | GNSS, SPS 模式/ GNSS, SPS mode |
| 3 | PPS 模式/ PPS model |

12.3 GSA-当前卫星信息/GSA- GNSS satellites in using

此条语句包含模块的选定工作模式，定位类型，已使用卫星的 PRN 信息及 PDOP, HDOP, VDOP 等信息。

This statement contains the selected working mode of the module, positioning type, PRN information of used satellites, PDOP, HDOP, VDOP and other information.

\$GNGSA,A,3,199,195,08,26,09,31,16,194,193,27,03,04,1.07,0.72,0.79,1*05

\$GNGSA,A,3,67,66,,,,,,,,,1.07,0.72,0.79,2*0E

\$GNGSA,A,3,,,,,,,,,1.07,0.72,0.79,3*0E

\$GNGSA,A,3,37,20,07,,,,,,,,,1.07,0.72,0.79,4*08

表 3-1 GSA 语句格式/GSA Data Format

| 名称/Name | 举例/Example | 单位/Units | 描述/Description |
|--------------------------------------|------------|----------|--|
| 语句 ID/ Message ID | \$GNGSA | | 表明语句为 GSA 信息/ Indicates that the statement is GSA information |
| 模式 1/ Mode 1 | A | | 表 3-3/ See Table 3-3 |
| 模式 2/ Mode 2 | 3 | | 表 3-2/ See Table 3-2 |
| 已使用卫星 ID 信息/ ID of satellite used | 199 | | 第一信道的 Sv 信息/Sv on Channel 1 |
| 已使用卫星 ID 信息/ ID of satellite used | 195 | | 第二信道的 Sv 信息/Sv on Channel 2 |
| ... | ... | | ... |
| 已使用卫星 ID 信息/ ID of satellite used | <Null> | | 十二信道的 Sv 信息（未使用则为空）/ Sv on Channel 12 (Null fields when it is not Used) |
| PDOP | 1.07 | | 综合位置精度因子/Position Dilution of Precision |
| HDOP | 0.72 | | 水平精度因子/Horizontal Dilution of Precision |
| VDOP | 0.79 | | 垂直精度因子/Vertical Dilution of Precision |
| 校验值 | *05 | | |

| | | |
|-----|-----------|----------------------------------|
| EOL | <CR> <LF> | 结束标志符/End of message termination |
|-----|-----------|----------------------------------|

表 3-2/Table 3-2

| 值/Value | 描述/Description |
|---------|----------------|
| 1 | 未定位 |
| 2 | 2D 定位 |
| 3 | 3D 定位 |

表 3-3 /Table 3-3

| 值/Value | 描述/Description |
|---------|------------------|
| M | 手动选择 2D 或者 3D 模式 |
| A | 自动选择 2D 或者 3D 模式 |

12.4 GSV-可见卫星信息//GSV- GNSS Satellites in View

此语句包含可见卫星的 PRNs, 方位角和仰角等信息。

This sentence contains the mode of operation, type of fix, PRN of the satellites used in the solution as well as PDOP, HDOP and VDOP.

\$GPGSV,4,1,13,27,78,149,46,199,60,149,39,04,59,289,43,194,56,045,44,1*64

\$GPGSV,4,2,13,195,54,108,43,16,50,008,43,08,45,203,42,26,33,038,40,1*5A

\$GPGSV,4,3,13,09,28,313,33,31,28,098,42,193,26,167,39,03,11,233,39,1*52

\$GPGSV,4,4,13,22,,,35,1*60

\$GPGSV,3,1,10,27,78,149,50,199,60,149,48,04,59,289,46,194,56,045,45,8*6C

\$GPGSV,3,2,10,195,54,108,46,08,45,203,48,26,33,038,36,09,28,313,31,8*54

\$GPGSV,3,3,10,193,26,167,44,03,11,233,43,8*55

\$GLGSV,1,1,02,66,38,231,37,67,31,297,33,1*7A

\$GAGSV,1,1,02,05,,,41,24,,,41,7*72

\$GAGSV,1,1,02,05,,,45,24,,,41,1*70

\$GBGSV,3,1,11,07,65,346,40,37,50,357,43,23,33,068,26,10,32,262,41,1*7A

\$GBGSV,3,2,11,20,28,264,35,01,,,42,02,,,36,16,,,42,1*48

\$GBGSV,3,3,11,03,,,40,05,,,28,32,,,38,1*74

\$GBGSV,1,1,04,37,50,357,41,23,33,068,45,20,28,264,37,32,,,41,4*44

表 4-1 GSV 语句格式/ GSV Data Format

| 名称/Name | 举例/Example | 单位/Units | 描述/Description |
|--------------------------------|------------|-----------|---|
| 语句 ID/Message ID | \$GPGSV | | 表明此语句为 GSV 信息/GSV protocol header |
| GSV 总数信息/ Number of Message | 4 | | 本次 GSV 语句的总条数/ Total number of GSV sentences |
| GSV 条数信息/ Message Number | 1 | | 本条语句为 GSV 语句中的第几条/ Sentence number of the total |
| 可见卫星信息/ Satellites in View | 13 | | 当前可见卫星总数/Number of satellites in view |
| 卫星 ID/Satellite ID | 27 | | |
| 卫星仰角/Elevation | 78 | 度/degrees | 范围 00 到 90/ Range 00 to 90 |
| 卫星方位角/Azinmuth | 149 | 度/degrees | 范围 000 到 359/ Range 000 to 359 |
| 信噪比(C/NO)/SNR(C/NO) | 46 | dB-Hz | 范围 00 到 90 (未使用则为空) / Range 00 to 99, null when not tracking |
| ... | | | ... |
| 可见卫星信息/ Satellites in View | 194 | | |
| 卫星 ID/Satellite ID | 56 | 度/degrees | 范围 00 到 90/ Range 00 to 90 |
| 卫星仰角/Elevation | 045 | 度/degrees | 范围 000 到 359/ Range 000 to 359 |
| 卫星方位角/Azinmuth | 44 | dB-Hz | 范围 00 到 90 (未使用则为空) / Range 00 to 99, null when not tracking |
| 校验值/Checksum | *64 | | |
| EOL | <CR> <LF> | | 结束标志符/End of message termination |

12.5 RMC-推荐定位信息/ RMC- Recommended locating information

此语句包含推荐定位的卫星定位信息。

This statement contains the satellite positioning information for the recommended location.

\$GNRMC,022326.000,A,2238.3443,N,11403.0962,E,0.01,169.33,120421,,,A,V*07

表 5-1: RMC 语句格式/ RMC Data Format

| 名称/Name | 举例/Example | 单位/Units | 描述/Description |
|---------|------------|----------|----------------|
|---------|------------|----------|----------------|

| | | | |
|------------------------------------|------------|---|--|
| 语句 ID/Message ID | \$GNRMC | | 表明此语句为 RMC 信息/RMC protocol header |
| UTC 时间/UTS Position | 022326.000 | | hhmmss.sss |
| 使用状态/Status | A | | A=数据已使用 V=数据未使用/A=data valid or V=data not valid |
| 纬度/ Latitude | 2238.3443 | | ddmm.mmmm |
| 纬度 N/S/ N/S Indicator | N | | N=北纬 S=南纬/N=north or S=south |
| 经度/Longitude | 11403.0962 | | dddmm.mmmm |
| 经度 E/W /E/W Indicator | E | | E=东经 W=西经/E=east or W=west |
| 速度/ Speed Over Ground | 0.01 | 节 | |
| 方位角/Course Over Ground | 169.33 | 度 | |
| UTC 日期/Date(UTC) | 120421 | | ddmmyy |
| 磁偏角/Magnetic variation | <Null> | 度 | 未使用则为空/Null fields when it is not Used |
| 磁偏角方位/Magnetic Variation Direction | <Null> | | E=东经 W=西经 /E=east or W=west |
| 定位模式/Fix Mode | A | | A=自动, N=未定位, D=DGPS, E=DR/ A=autonomous, N = No fix, D=DGPS, E=DR |
| 校验值/Checksum | *07 | | |
| EOL | <CR> <LF> | | 结束标志符/End of message termination |

12.6 GLL-地理定位信息/Geographic Position – Latitude/Longitude

包含纬度和经度信息。

This sentence contains the fix latitude and longitude.

\$GNGLL, 2238.3443,N, 11403.0962,E, 022326.000,A,A*4F

表 6-1: GLL 数据格式/GLL Data Format

| 名称/Name | 举例/Example | 单位/Units | 描述/Description |
|---------------------|------------|----------|---------------------|
| 语句/ Message ID | \$GNGLL | | GLL protocol header |
| 纬度/ Latitude | 2238.3443 | | ddmm.mmmm |
| 南北纬度/N/S Indicator | N | | N=north or S=south |
| 经度/ Longitude | 11403.0962 | | dddmm.mmmm |
| 东西经度/ E/W Indicator | E | | E=east or W=west |

| | | | |
|----------------------|------------|--|--|
| UTC 定位/ UTC Position | 022326.000 | | hhmmss.sss |
| Fix 状态/Fix Status | A | | A=data valid or V=data not valid |
| Fix 模式/Fix Mode | A | | A=autonomous, N = No fix, D=DGPS, E=DR |
| 校验和/ Checksum | *4F | | |
| EOL | <CR> <LF> | | 信息结束标志符/End of message |

12.7 VTG-地面速度信息/VTG- Course Over Ground and Ground Speed

此语句包含地面速度信息。

This statement contains the ground speed information.

\$GNVTG,169.33,T,,M,0.01,N,0.02,K,A*2E

表 7-1: VTG 语句格式/VTG statement format

| 名称/Name | 举例/Example | 单位/Units | 描述/Description |
|---|------------|----------|--|
| 语句 ID/Message ID | \$GNVTG | | 表明此语句为 VTG 信息/VTG protocol header |
| 以真北为参考的地面航向 /Ground course with true north as reference | 169.33 | | 000~359 度，前面的 0 也将被传输/At 000~359 degrees, the front 0 will also be transmitted |
| 间隔符/Blank character | T | | |
| 以磁北为参考的地面航向 /Ground heading with magnetic north as reference | <Null> | | 000~359 度，前面的 0 也将被传输/At 000~359 degrees, the front 0 will also be transmitted |
| 间隔符/Blank character | M | | |
| 地面速率/Ground rate | 0.01 | Knots | 000.0~999.9 |
| 间隔符 /Blank character | N | | |
| 地面速率/Ground rate | 0.02 | Km / h | 0000.0~1851.8Km / h |
| 间隔符 /Blank character | K | | |
| 模式指示/Mode indication | A | | A=自主定位，D=差分，E=估算，N=数据无效/ A= autonomous localization, D= difference, E= imputation, and N= invalid data |
| EOL | <CR> <LF> | | 结束标志符/ End of message termination |

12.8 ZDA-时间日期信息/ ZDA- Date and Time

此语句包含时间和日期信息

This sentence contains UTC date & time, and local time zone offset information.

```
$GNZDA,022326.000,12,04,2021,,*49
```

表 8-1: ZDA 语句格式/ ZDA Data Format

| 名称/Name | 举例/Example | 单位/Units | 描述/Description |
|---------------------|------------|----------|-----------------------------------|
| 语句 ID/Message ID | \$GNZDA | | 表明此语句为 ZDA 信息/ZDA protocol header |
| UTC 时间/UTC Time | 022326.000 | | hhmmss (时分秒) 格式 |
| UTC 日期/UTC data | 12 | | 日 |
| UTC 日期/UTC Month | 04 | | 月 |
| UTC 日期/UTC Year | 2021 | | 年 |
| 时区/local zone hours | <Null> | | |
| 校验值/Checksum | *49 | | |
| EOL | <CR> <LF> | | 结束标志符/ End of message termination |

13 联系方式/ Contact Information

Skylab M&C Technology Co., Ltd.

深圳市天工测控技术有限公司

地址: 深圳市龙华区龙华街道工业东路利金城科技工业园 9# 厂房 6 楼

电话: 86-755 8340 8210 (Sales Support)

电话: 86-755 8340 8510 (Technical Support)

传真: 86-755-8340 8560

邮箱: technicalsupport@skylab.com.cn

网站: www.skylab.com.cn www.skylabmodule.com