



CW2217BAAD

Fuel Gauge IC with Current Sensing

Features

- System-Side or Pack-Side Fuel Gauging
- High C-Rate Charging Compliance
- High precision ADCs for Voltage, Current and Temperature Measurement
- High Side or Low Side Current Sensing
- Support Low to 1mOhm Sense Resistor
- External Thermistor or Host Reported Temperature
- Battery Voltage, Current, Temperature, SOC, and Cycle Count Report
- No Offset Accumulation during Life Time
- No Full-To-Empty Calibration Cycles Required
- Interrupt for SOC, Temperature and 1% SOC Change
- Ultra-low Power Consumption
 - Active Mode 12 μ A
 - Shutdown Mode 0.5 μ A
- General I²C Control Interface
- Lead-Free, DFN-12 Package

Applications

- Power Banks
- Tablets and Laptops
- Power Tools
- Li+ Battery Pack

General Description

The CW2217 is an ultra-compact, system-side or pack-side fuel gauging IC for Lithium-ion based batteries used in wearable and portable devices.

The CW2217 tracks battery operating conditions and performs state-of-the-art algorithm to calculate the State-of-Charge (SOC) of various battery chemistry systems, including LiCoOx, polymer Li-ion and LiMnOx etc.

The CW2217 includes two high precision ADCs, voltage reference circuits and build-in NTC thermistor bias circuits. It continually monitors the battery voltage and temperature and measures the current flow through the sense resistor. All the measurements and the battery characterization data are utilized by the IC embedded FastCali algorithm and accurate battery SOC is reported and refreshed in a wide variety of operating conditions.

The CW2217 also provides alarm functions. When SOC or temperature reaches the pre-programmed threshold, the relevant interrupt will be generated to alert the host MCU.

The CW2217 use a 2-wire I²C compatible serial interface that operates in standard mode or fast mode. The CW2217BAAD is available in lead-free 2.5mmx4.0mm, 12-lead DFN package.

Typical Application

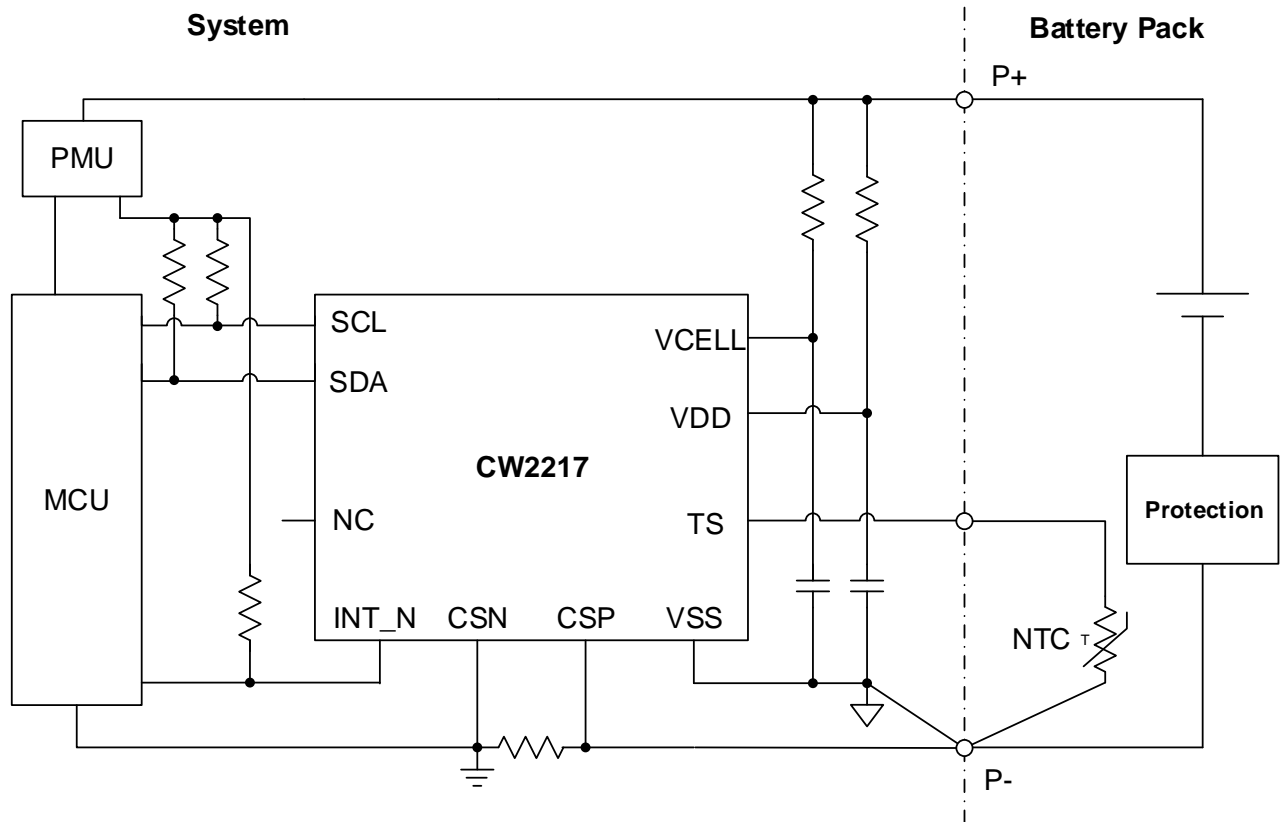

Figure 1. Typical Application for Single Cell

Ordering Information

PART	I ² C ADDRESS	OPERATING TEMPERATURE	PACKAGE	TOP MARK	SHIPPING
CW2217BAAD	0x64	-40°C to 85°C	DFN-12	2217BA ADXXXX	Tape&Reel/ 6000

Note: XXXX stands for manufacture info. Contact manufacturer for details.

Pin Configuration

Package DFN-12

Top view

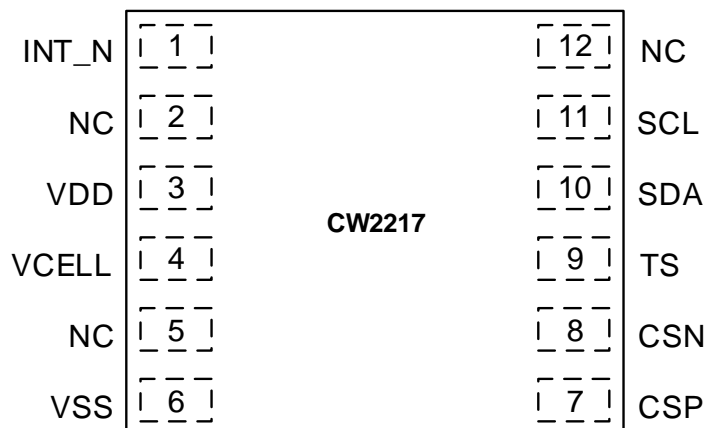

Pin Descriptions

PIN	NAME	DESCRIPTION
3	VDD	IC power supply
4	VCELL	Battery voltage monitor I/O
6	VSS	General purpose ground connection
7	CSP	Current sensing positive input
8	CSN	Current sensing negative input
9	TS	NTC measuring I/O
2, 5, 12	NC	NC pin, no connection with any internal circuits
10	SDA	Serial data input/output
11	SCL	Serial clock input
1	INT_N	Alarm signal for MCU interrupt controller; open drain output

Type Number

CW2217XXXX

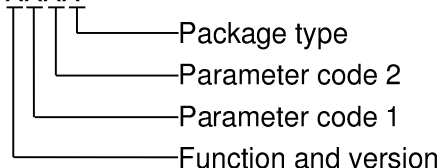

- D: DFN package
- A: Standard firmware
- A: Standard Li+ battery profile
- B: Product version

Absolute Maximum Ratings

		VALUE		UNITS
		MIN	MAX	
Voltage respect to GND	VCELL, VDD, CSP, CSN, INT_N, TS, SCL, SDA	-0.3	6	V
Output Current	INT_N, SDA		10	mA
Operation Temperature	T _A	-40	85	°C
Junction Temperature	T _J	-40	150	°C
Storage Temperature	T _{STG}	-60	150	°C
ESD	All pins. HBM model.		±2000	V
	All pins. CDM model.		±1000	V
Moisture Sensitivity Level	MSL	Level 3		

Caution:

Stresses beyond "Absolute Maximum Ratings" condition may cause permanent damage to the device. These are stress ratings only and functional operation of the device at these or any other beyond those indicated in the operational sections of the specifications is not implied. Exposure to absolute maximum rating conditions for extended periods may affect device reliability.

Recommended DC Operating Conditions

PARAMETER	DESCRIPTION	MIN	MAX	UNITS
Input Voltage Range	VDD, INT_N, TS, SCL, SDA	-0.3	5.5	V
Input Voltage Range	VCELL	-0.3	5.0	V
Input Voltage Range	CSP, CSN	-0.3	V _{CELL} +0.3	V
I ² C Clock Frequency			400	kHz
Operation Temperature		-40	85	°C

Electrical Characteristics

2.5V ≤ V_{DD} ≤ 5.5V, T_A = -40 to 85°C, unless otherwise noted

PARAMETER	SYMBOL	CONDITIONS	MIN	TYP	MAX	UNIT
POWER SUPPLY CONTROL						
V _{DD} power on threshold	V _{ON_VDD}	I ² C communication enable		2.4		V
V _{DD} power off threshold	V _{OFF_VDD}	I ² C communication stop		2.2		V
QUIESCENT CURRENT						
Shutdown mode current	I _{SD}			0.5		μA
Active normal mode current	I _{NOR}			12		μA
CELL VOLTAGE MEASUREMENT ADC CHARACTERISTICS						
Cell pin measurement range	V _{CELL}		2.5		5.0	V
Conversion time	t _{ADC_CONV}			5		ms
Effective bits				14		bits
Measurement resolution	V _{LSB_CELL}			312.5		μV
Measurement error	V _{ERR_CELL}	T _A = 25°C and cell voltage is 4V	-7.5		7.5	mV
		T _A = -20 to 70°C	-12		12	mV
		T _A = -40 to 85°C	-20		20	mV
TS PIN TEMPERATURE ADC CHARACTERISTICS						
Measurement range	V _{TS}		0		2.1	V
Conversion time	t _{ADC_CONV}			5		ms
Effective bits				14		bits
Measurement resolution	V _{LSB_TS}			312.5		μV
Measurement error	V _{ERR_TS}	T _A = 25°C	-7.5		7.5	mV
		T _A = -20 to 70°C	-12		12	mV
		T _A = -40 to 85°C	-20		20	mV
CURRENT MEASUREMENT ADC CHARACTERISTICS						
CSP-CSN full scale magnitude	V _{CSP-CSN}			±52.4		mV
Conversion time	t _{CADC_CONV}			10		ms
Effective bits				16		bits
Measurement offset	V _{ZERO_OFF}			±1		LSB
Measurement error	I _{ERR}	Current=1A, R _{sense} =10mohm	-1		1	%
DIGITAL IO CHARACTERISTICS						
Input voltage, high	V _{IH(OD)}	SDA, SCL and INT_N	1.4			V
Input voltage, low	V _{IL(OD)}	SDA, SCL and INT_N			0.5	V
Output voltage, low	V _{OL}	SDA and INT_N with 4mA current sink			0.3	V

Electrical Characteristics: I²C Interface

2.5V ≤ V_{DD} ≤ 5.5V, T_A = -40 to 85°C, unless otherwise noted

PARAMETER	SYMBOL	TEST CONDITIONS	MIN	TYP	MAX	UNIT
Clock operating frequency	f _{SCL}		10		400	kHz
Bus free time between a STOP and START condition	t _{BUF}		1300			ns
Low period of SCL clock	t _{LOW}		1300			ns
High period of SCL clock	t _{HIGH}		600			ns
SDA data setup time	t _{SU:DAT}		100			ns
SDA data hold time	t _{HD:DAT}		0		900	ns
Hold time after START condition	t _{HD:STA}		600			ns
Setup time for a repeated START condition	t _{SU:STA}		600			ns
Fall time for SDA, SCL	t _F		20		300	ns
Rise time for SDA, SCL	t _R		20		300	ns
Spike pulse widths suppressed by input filter	t _{SP}		0		50	ns
Setup time for STOP condition	t _{SU:STO}		600			ns
Capacitive load for each bus line	C _B				400	pF
SDA, SCL input capacitance	C _{BIN}				60	pF

I²C Timing Diagram

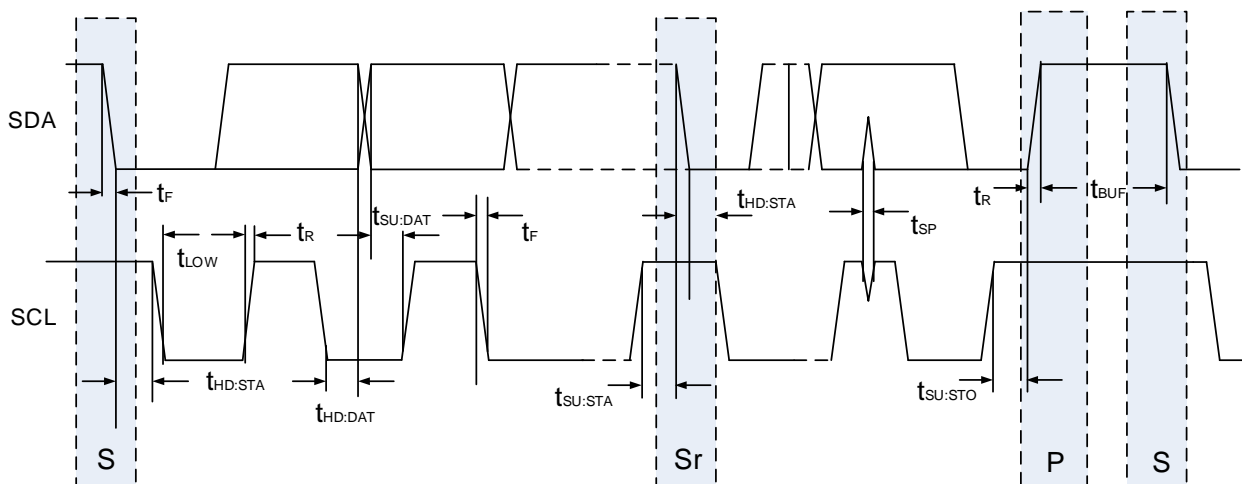

Figure 2. I²C Timing Diagram

Function Block Diagram

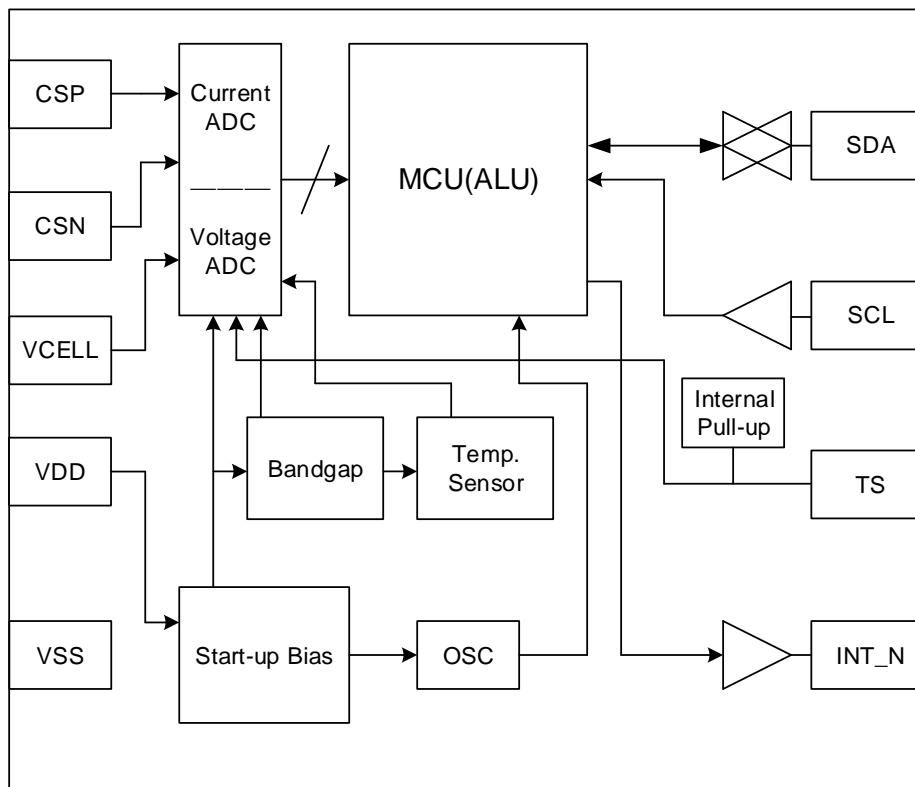

Figure 3. Function Block Diagram

Detailed Description

Power States

After power up, the CW2217 stays in shutdown mode by default to minimize power consumption. The IC needs two steps to enter active mode, in which normal gauging is in operation: step one, clear sleep register by writing 0x30 to REG 0x08; step two, clear restart register by writing 0x00 to REG 0x08.

FastCali Algorithm

The FastCali algorithm embedded in the CW2217 could calculate the SOC based on the battery characterization data and the measurement of battery voltage, temperature and charging or discharging current. It can achieve high accuracy SOC calculation across wide operating conditions and over the battery lifetime. It does not accumulate error with time and current, which is a big advantage compared to the coulomb counter (CC). The CC suffers from SOC drift caused by the accumulation error of current sense offset and battery self-discharge.

First SOC Estimation after Power Up

After power up, the CW2217 will take the first voltage and current measurement and calculate the OCV, and then get the first SOC. The first SOC error could be healed during the following normal usage since more battery data can be used for calibration.

Temperature Measurement

The TS pin of the CW2217 is the external battery temperature sensing pin and its driving circuits (internal pull-up) are integrated. The measured temperature is utilized by the gauge algorithm directly and could be read by the host MCU too. 10kohm, 47kohm and 100kohm NTC thermistors are supported and the thermistor type selection is in the battery profile, 10kohm NTC is selected by default.

Part	NTC Thermistor Supported
CW2217	R25C=10kΩ±1%, β(25/85) value = 3435K±1%
	R25C=10kΩ±1%, β(25/50) value = 3380K±1%
	R25C=47kΩ±1%, β(25/50) value = 4050K±1%
	R25C=100kΩ±1%, β(25/50) value = 4250K±1%

Table 1. NTC Thermistor Selection Guide

The CW2217 also supports host reported temperature. For accurate SOC calculation, the host MCU need to timely transfer the battery temperature to the gauge IC when TS pin sensing is not used. The selection of the temperature measurement source is in the battery profile.

Interrupt

The CW2217 have 3 interrupt sources: SOC change, Max. temperature and Min. temperature. The INT source enable bit should be set before used. If any INT event occur, the relevant register status bit in INT_CONF [3:0] of register 0x0A will be set and the INT_N pin will generate a low pulse with about 1ms duration to inform the host MCU. The host needs to clear the INT status bit to prevent from missing any new coming INT event.

Note that the 1ms low pulse will keep on popping up in the interval of 1 second or longer until the current INT event is gone. For example, when the measured temperature is over Max. temperature threshold continually, low pulse will keep on popping up on the INT_N pin.

Battery Profile

The battery profile of the CW2217 is programmable to match battery parameters, such as various maximum charging voltages, like 4.20V, 4.35V, 4.40V or other values. User's battery needs to have battery characterization to get its exclusive profile for more accurate SOC calculation. Contact distributor to have the battery characterization.

Besides battery characteristic relevant info, some configurations are included in the battery profile too. For example, the current sensing calibration value is stored in the profile since it is user's design related parameter.

Register Map

Below table shows the I²C register map of the CW2217.

REGISTER NAME	ADDRESS	DESCRIPTION	READ/ WRITE	DEFAULT VALUE
VERSION	0x00	IC version	R	0xA0
VCELL_H	0x02	VCELL voltage conversion result, VCELL[13:8]	R	0x00
VCELL_L	0x03	VCELL voltage conversion result, VCELL[7:0]	R	0x00
SOC_H	0x04	SOC result, SOC[15:8]	R	0x00
SOC_L	0x05	SOC result, SOC[7:0]	R	0x00
TEMP	0x06	Battery NTC thermistor temperature, TEMP[7:0]	R/W	0x82
CONFIG	0x08	IC configuration	R/W	0xF0
INT_CONF	0x0A	Interrupt configuration	R/W	0x40
SOC_ALERT	0x0B	SOC interrupt threshold	R/W	0x14
TEMP_MAX	0x0C	Maximum temperature threshold	R/W	0xAA
TEMP_MIN	0x0D	Minimum temperature threshold	R/W	0x50
CURRENT_H	0x0E	Current conversion result [15:8]	R	0x00
CURRENT_L	0x0F	Current conversion result [7:0]	R	0x00
T_HOST_H	0xA0	Host reported temperature, T_HOST[15:8]	R/W	0x00
T_HOST_L	0xA1	Host reported temperature, T_HOST[7:0]	R/W	0x00
USER_CONF	0xA2	Configurable register for developer	R/W	0x00
CYCLECNT_H	0xA4	Battery charging cycles, CYCLECNT[15:8]	R	0x00
CYCLECNT_L	0xA5	Battery charging cycles, CYCLECNT[7:0]	R	0x00
SOH	0xA6	Battery state of health, SOH[7:0]	R	0x00
STB_CUR_H	0xA8	Standby current conversion result [15:8]	R	0x00
STB_CUR_L	0xA9	Standby current conversion result [7:0]	R	0x00
FW_VERSION	0xAB	Firmware version	R	0x00

Table 2. Register Map

VERSION Register (0x00)

The VERSION register is an **UNSIGNED** 8bit read-only register. Its value is fixed to 0xA0 in shutdown mode and active mode, which is the CW2217 IC version.

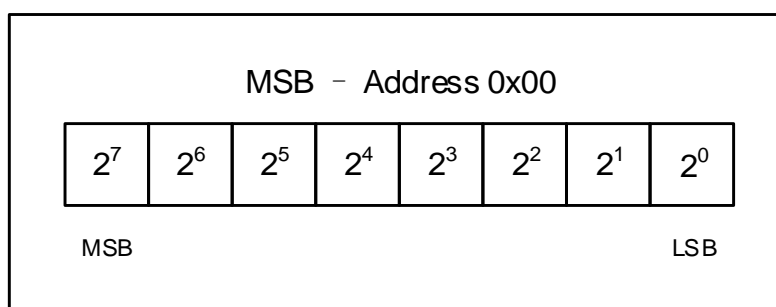

Figure 4. VERSION Register Format

VCELL Register (0x02~0x03)

The VCELL register is an **UNSIGNED** 14bit read-only register that updates the battery voltage continuously. Battery voltage is measured between the VCELL pin and VSS pin, which is the ground reference. A 14bit sigma-delta A/D converter is used and the voltage resolution is 312.5µV.

$$V(\mu V) = \text{Value}_{(0x02\ 0x03\ DEC)} * 312.5$$

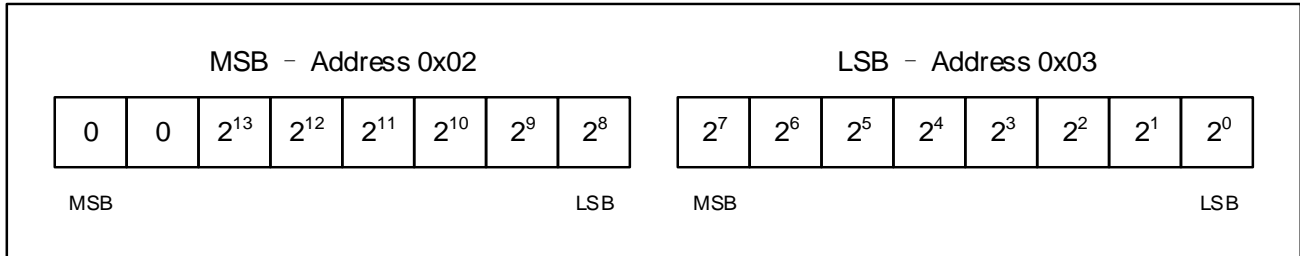

Figure 5. VCELL Register Format

SOC Register (0x04~0x05)

The SOC register is an **UNSIGNED** 16bit read-only register that indicates the SOC of the battery. The SOC shows in % format, which means how much percent of the battery’s total available capacity is remaining in the battery now. The SOC can intrinsically adjust itself to cater to the change of battery status, including load, temperature and aging etc.

The high byte(0x04) contains the SOC in 1% unit which can be directly used if this resolution is good enough for the application. The low byte(0x05) provides more accurate fractional part of the SOC and its LSB is (1/256) %.

$$\text{SOC}(\%) = \text{Value}_{(0x04\ DEC)} + \frac{\text{Value}_{(0x05\ DEC)}}{256}$$

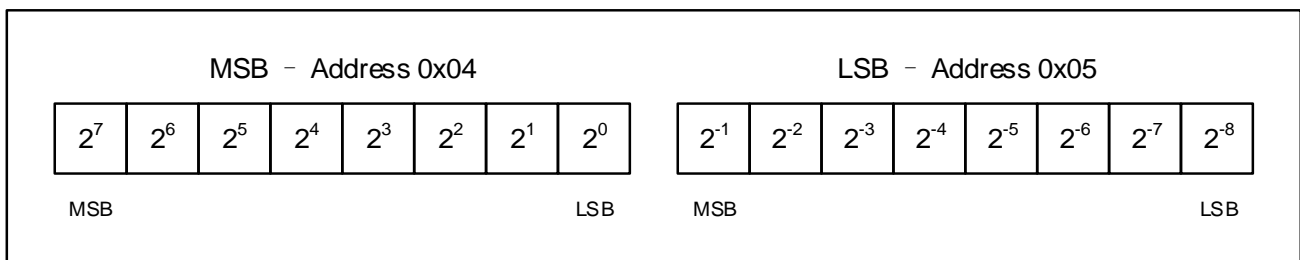

Figure 6. SOC Register Format

TEMP Register (0x06)

The TEMP register is an **UNSIGNED** 8bit read only register. It reports the real-time battery temperature measured at TS pin. The scope is from -40 to 87.5 degrees Celsius, LSB is 0.5 degree Celsius.

$$\text{TEMP}(\text{°C}) = -40 + \frac{\text{Value}_{(0x06\ DEC)}}{2}$$

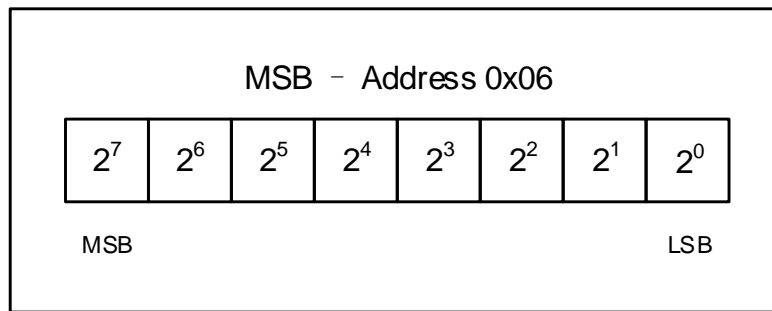

Figure 7. TEMP Register Format

CONFIG Register (0x08)

The CONFIG register is used for the host MCU to configure the fuel gauge IC. The default value is 0xF0, SLEEP and RESTART bits are set. To power up the IC, the host MCU needs to write 0x30 to exit shutdown mode, and then write 0x00 to restart the gauge to enter active mode. To reset the IC, the host MCU needs to write 0xF0, 0x30 and 0x00 in sequence to this register to complete the restart procedure. The CW2217 will reload relevant parameters and settings and restart SOC calculation. Note that the SOC may be a different value after reset operation since it is a brand-new calculation based on the latest battery status. CONFIG [3:0] is reserved. Don't do any operation with it.

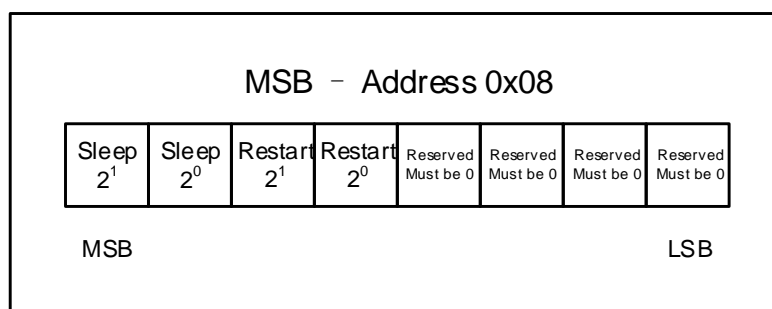

Figure 8. CONFIG Register Format

INT_CONF Register (0x0A)

INT_CONF [6:4] are used to enable interrupt source, and INT_CONF [2:0] indicate relative INT event. There are three interrupt sources. SOC_INT indicates SOC change. TMX_INT is the maximum temperature flag. It will be set when temperature is higher than TEMP_MAX(0x0C). TMN_INT is the minimum temperature flag. It will be set when temperature is lower than TEMP_MIN(0x0D).

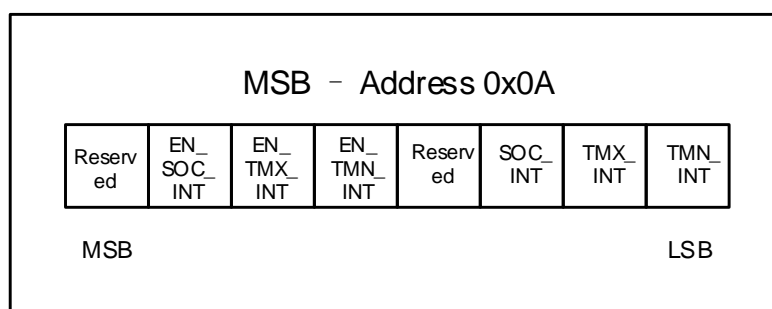

Figure 9. INT_CONF Register Format

SOC_ALERT Register (0x0B)

UPDATE_FLAG [7] can be set to “1” by the host MCU after the battery profile is successfully loaded. Since it will be clear after POR, it can be used to check whether the IC has been reset. Its default value is “0”. SOC_ALERT [6:0] configures the specified SOC alarm threshold to remind the host MCU. For instance, set it to 0x14 means that SOC_INT will be set when the SOC updates downward from 0x15 to 0x14 or upward from 0x13 to 0x14. If set SOC_ALERT [6:0] to any value from 0x65 to 0x7F, the SOC_INT will generate as long as the integer part of the SOC Register (0x04) has been changed.

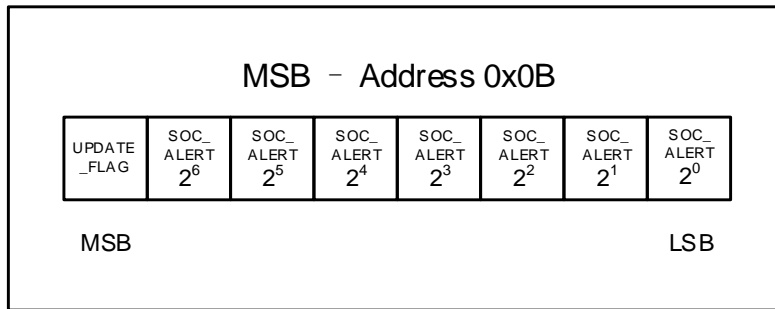

Figure 10. SOC_ALERT Register Format

TEMP_MAX Register (0x0C)

TEMP_MAX is the maximum temperature alert threshold. When temperature reach this value, TMX_INT (0x0A) bit is set, and a low pulse is sent on INT_N pin. LSB is 0.5 degree Celsius.

$$TEMP_{MAX}(^{\circ}C) = -40 + \frac{Value_{(0x0C\ DEC)}}{2}$$

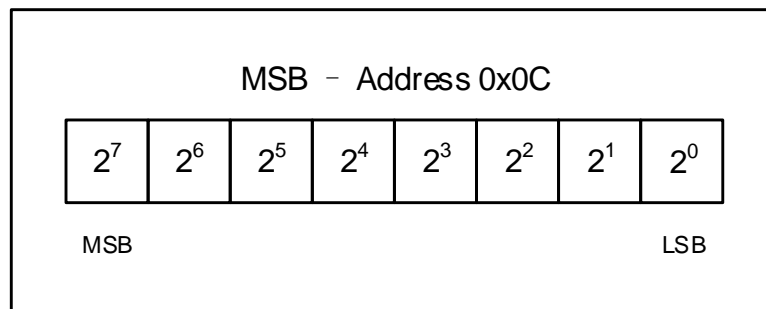

Figure 11. TEMP_MAX Register Format

TEMP_MIN Register (0x0D)

TEMP_MIN is the minimum temperature alert threshold. When temperature reach this value, TMN_INT (0x0A) bit is set, and a low pulse is sent on INT_N pin. LSB is 0.5 degree Celsius.

$$TEMP_{MIN}(^{\circ}C) = -40 + \frac{Value_{(0x0D\ DEC)}}{2}$$

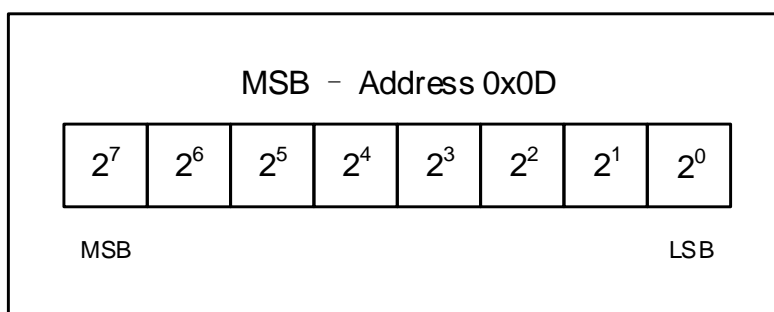

Figure 12. TEMP_MIN Register Format

CURRENT Register (0x0E~0x0F)

CURRENT is a **SIGNED** 16bit register that reports current A/D converter result of the voltage across the current sense resistor, 10mohm typical. The result is stored as a two’s complement value to show positive and negative current. Voltages outside the minimum and maximum register values are reported as the minimum or maximum value.

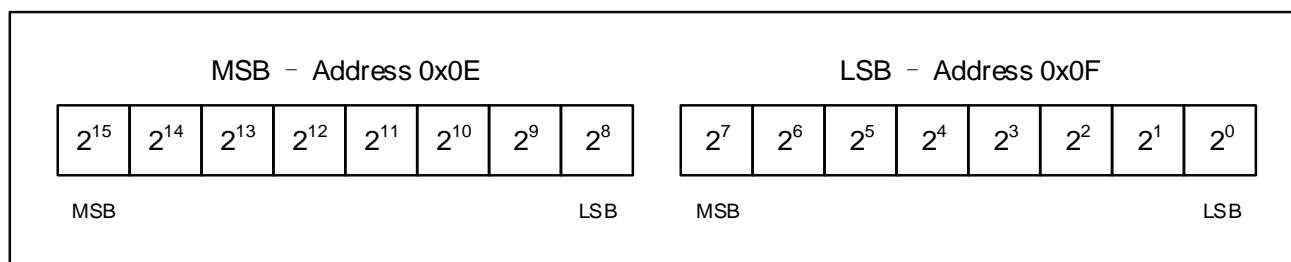

Figure 13. CURRENT Register Format

The register value should be divided by the sense resistance to convert to amperes. The value of the sense resistor determines the resolution and the full-scale range of the current readings. The LSB of 0x0F is (52.4/32768) mV. Table 3 shows range and resolution values for typical sense resistances. The default value is 0x0000, stands for 0mA. 0x7FFF stands for the maximum charging current and 0x8001 stands for the maximum discharging current.

$$I(A) = \frac{52.4 * Value_{(0x0E\ 0x0F\ DEC)}}{32768 * Rsense(m\Omega)}$$

Sense Resistor (mΩ)	Current Register Resolution (μA)	Current Register Range (A)
1	1600	±52.4
2	800	±26.2
5	320	±10.5
10	160	±5.2
50	32	±1.05

Table 3. Current Measurement Range and Resolution vs. Sense Resistor Value

T_HOST Register (0xA0~0xA1)

T_Host is an **UNSIGNED** 16bit register where the host MCU could write its reported temperature via I²C

interface. The high byte 0xA0 contains the host reported temperature in 0.5 degree Celsius unit and the low byte 0xA1 provides more accurate part of the host reported temperature in 1/512 degree Celsius unit. The algorithm checks this register value about every second when host reported temperature is configured. The low byte 0xA1 must be a different value compare with the previous temperature, otherwise, both 0xA0 and 0xA1 value are neglected by the algorithm.

To secure the host timely refresh its reported temperature to the fuel gauge IC, an alarm feature can be used to remind the host. When the algorithm has not gotten a new valid temperature over 16 seconds, the high temperature INT will generate and the TMX_INT bit of Register 0x0A will be set when the EN_TMX_INT bit of Register 0x0A is enabled. When high temperature alarm happens, the host can write “0” to clear the TMX_INT bit.

$$T_HOST(^{\circ}C) = -40 + \frac{Value_{(0xA0\ DEC)}}{2} + \frac{Value_{(0xA1\ DEC)}}{512}$$

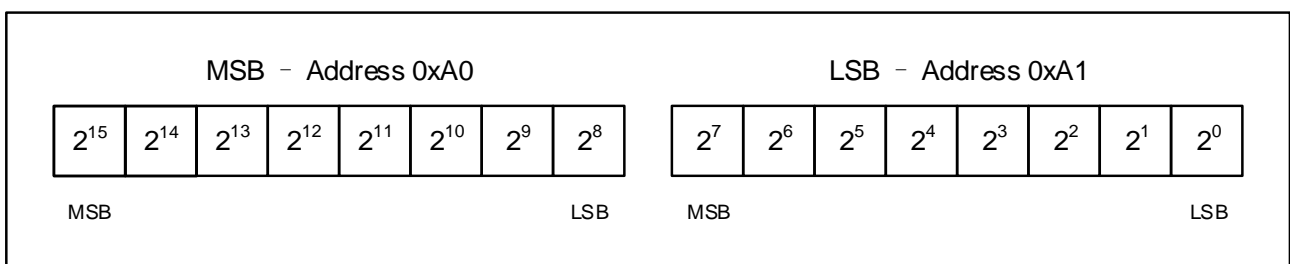

Figure 14. T_HOST Register Format

USER_CONF Register (0xA2)

USER_CONF is a free configurable 8bit register which can be read or write by developers directly.

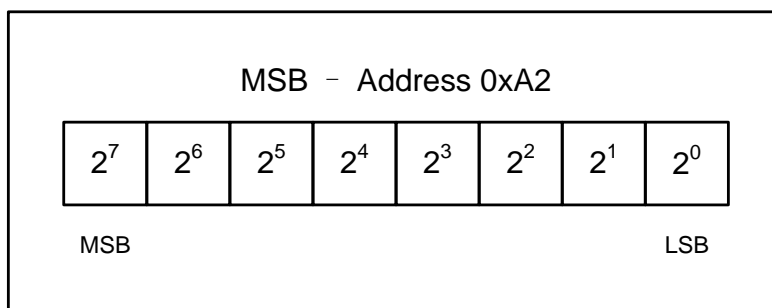

Figure 15. USER_CONF Register Format

CYCLECNT Register (0xA4~0xA5)

CYCLECNT is an **UNSIGNED** 16bit register that counts cycle life of the battery. The LSB of 0xA5 stands for 1/16 cycle. This register will be clear after enters shutdown mode.

$$Cycle\ Count = \frac{Value_{(0xA4\ 0xA5\ DEC)}}{16}$$

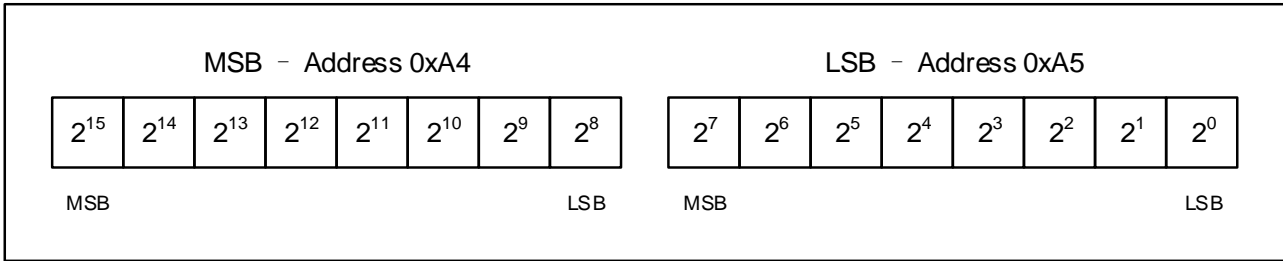

Figure 16. CYCLECNT Register Format

SOH Register (0xA6)

SOH (State of Health) is an **UNSIGNED** 8bit register that represents the level of battery aging by tracking battery internal impedance increment. When the device enters active mode, this register refresh to 0x64 by default. Its range is 0x00 to 0x64, indicating 0 to 100%. This register will be clear after enters shutdown mode.

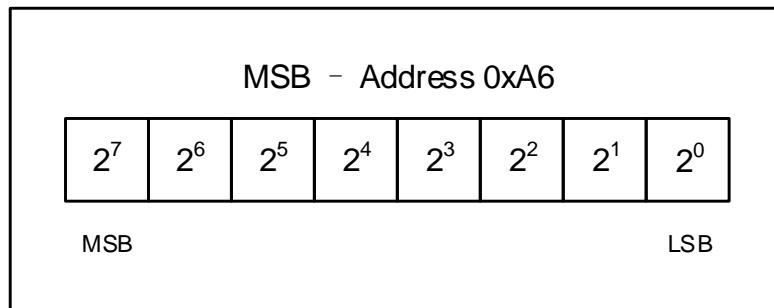

Figure 17. SOH Register Format

STB_CUR Register (0xA8-0xA9)

STB_CUR is a **SIGNED** 16bit register that reports the equipment standby current. It automatically reports the average standby current of the past 64 seconds when the equipment is in low power standby state. The result is stored as a two's complement value to show positive and negative current.

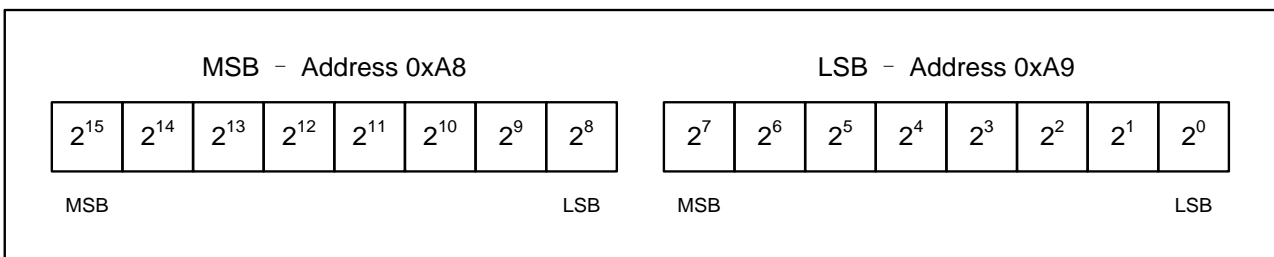

Figure 18. STB_CUR Register Format

The register value should be divided by the sense resistance to convert to amperes. Note that the full range of STB_CUR register is only 1/16 of that of CURRENT register. Thus, the LSB of 0xA9 is (52.4/32768)/16 mV. For a 10mohm sense resistor, the standby current full range is -327.5mA to +327.5mA. The register default value is 0x0000, stands for 0mA.

$$I(A) = \frac{52.4 * Value_{(0xA8\ 0xA9\ DEC)}}{16 * 32768 * Rsense(m\Omega)}$$

FW_VERSION Register (0xAB)

FW_VERSION register reports the firmware (FW) running in the chip. It is fixed to 0x00 when the chip is in shutdown mode. When in active mode, Bit [7:6] are fixed to '01', which stand for the CW2217 and Bit [5:0] stand for the FW version running in the chip. Note that the FW version is subject to update and contact sales office for confirmation when necessary.

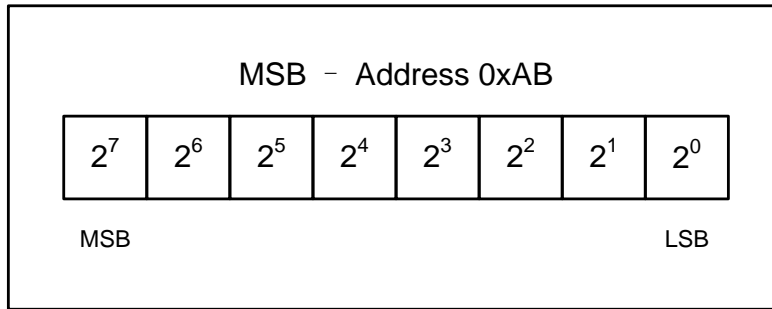

Figure 19. FW_VERSION Register Format

I²C Characteristics

The CW2217 includes an I²C bus which provides access to internal registers to program parameters and report device status. To adjust these parameters, data transmission from the host to the CW2217 and vice versa must take place through the two wires. The two wires of the bus consist of the SDA line, over which all data is sent and the SCL line which is a clock signal used to synchronize sending/receiving of the data. Data on the I²C bus can be transferred up to 100kbps in the standard mode or up to 400kbps in the fast mode. When the bus is free, both lines are HIGH. The device operates as a slave device. The I²C interface of the CW2217 works after the supply voltage rises above POR threshold.

Data Validity

The data on the SDA line must be stable during the HIGH period of the SCL, unless generating a START or STOP condition. The HIGH or LOW state of the data line can only change when the clock signal on the SCL line is LOW. One clock pulse is generated for each data bit transferred.

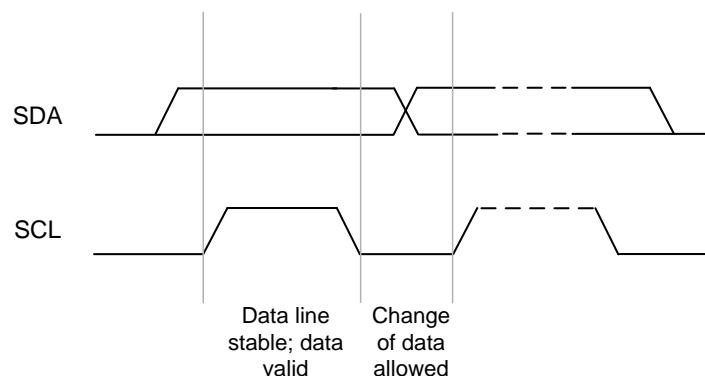

Figure 20. Bit Transfer on the I2C Bus

START and STOP Conditions

All transactions begin with a START (S) and are terminated by a STOP (P). A HIGH to LOW transition on the SDA line while SCL is HIGH defines a START condition. A LOW to HIGH transition on the SDA line while SCL is HIGH defines a STOP condition. START and STOP conditions are always generated by the master. The bus is considered to be busy after the START condition and free after the STOP condition.

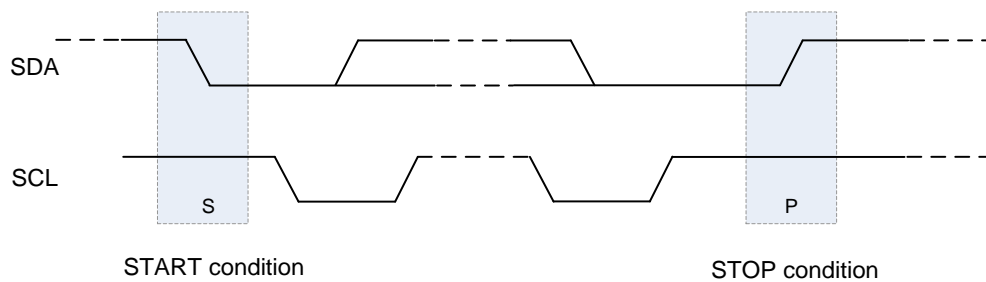

Figure 21. START and STOP Conditions

Byte Format

Every byte put on the SDA line must be eight bits long, the number of bytes that can be transmitted per transfer is unrestricted. Each byte must be followed by an Acknowledge bit. Data is transferred with the MOST Significant Bit (MSB) first.

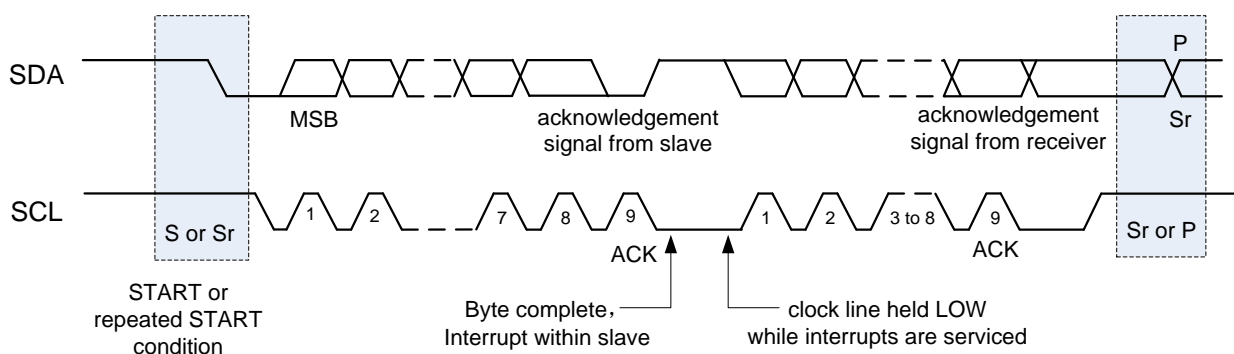

Figure 22. Data Transfer on the I2C Bus

Acknowledge (ACK) and Not Acknowledge (NACK)

The acknowledge takes place after each byte. The acknowledge bit allows the receiver to signal the transmitter that the byte was successfully received and another byte may be sent. The master generates all clock pulses, including the ACK ninth clock pulse. The ACK signal is defined as follows: The transmitter releases the SDA line during the acknowledge clock pulse so the receiver can pull the SDA line LOW and it remains stable LOW during the HIGH period of this clock pulse. When SDA remains HIGH during this ninth clock pulse, this is defined as the NACK signal. The master can then generate either a STOP condition to abort the transfer, or a repeated a START condition to start a new transfer.

The Slave Address and R/W Bit

After the START condition (S), a slave address is sent. This address is seven bits long followed by an eighth bit which is data direction bit (R/W), a 'zero' indicates a transmission (WRITE), a 'one' indicates a request for data (READ). A data transfer is always terminated by a STOP condition (P) generated by the master.

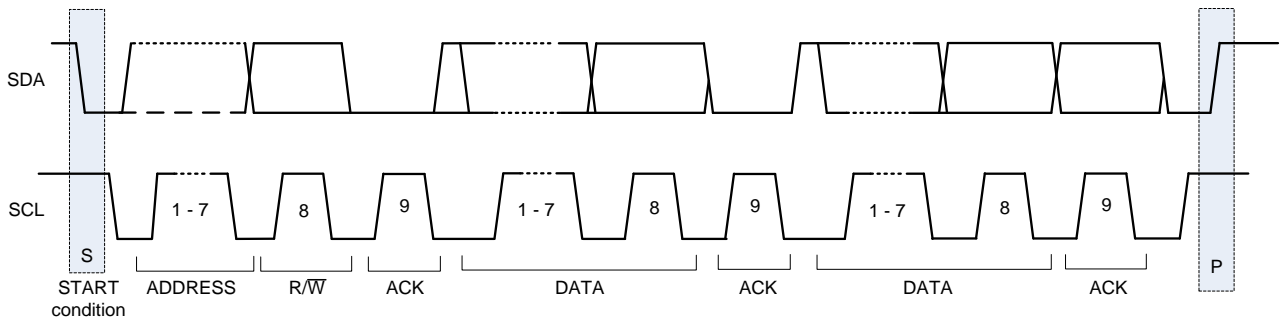

Figure 23. Complete Data Transfer

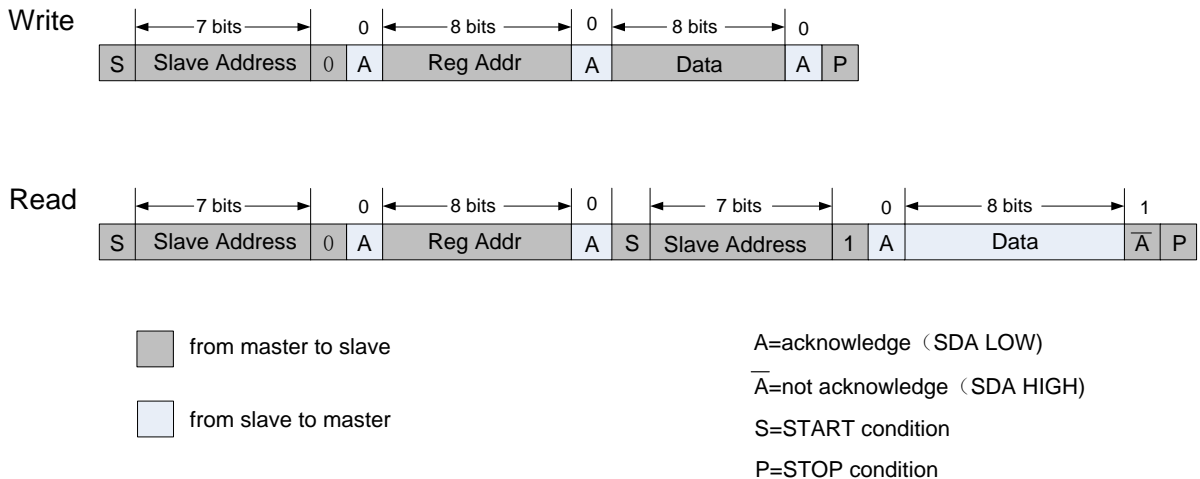

Figure 24. Write and Read Transaction

Device Address

I²C device address is consisted of 7bits slave address and 1 read/write control bit.

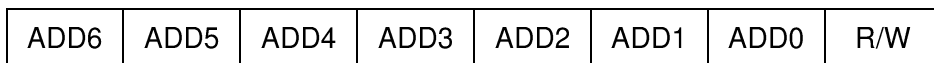

Figure 25. I²C Address Format

7bits address of CW2217BAAD is 0b1100100 or 0x64. Combine with the R/W bit:

Read command is 0xC9;

Write command is 0xC8.

Application and Implementation

The CW2217 provides fuel gauging for single-cell Li-Ion batteries. Battery fuel gauging with the fuel gauge requires connections only to P+ and P- for a removable battery pack or embedded battery circuits. It supports low-side current sensing or high-side current sensing. Battery temperature can be measured via the TS pin on the NTC thermistor in the pack. To allow for optimal performance, special considerations must be taken to ensure robustness of the application circuits and minimization of measurement error.

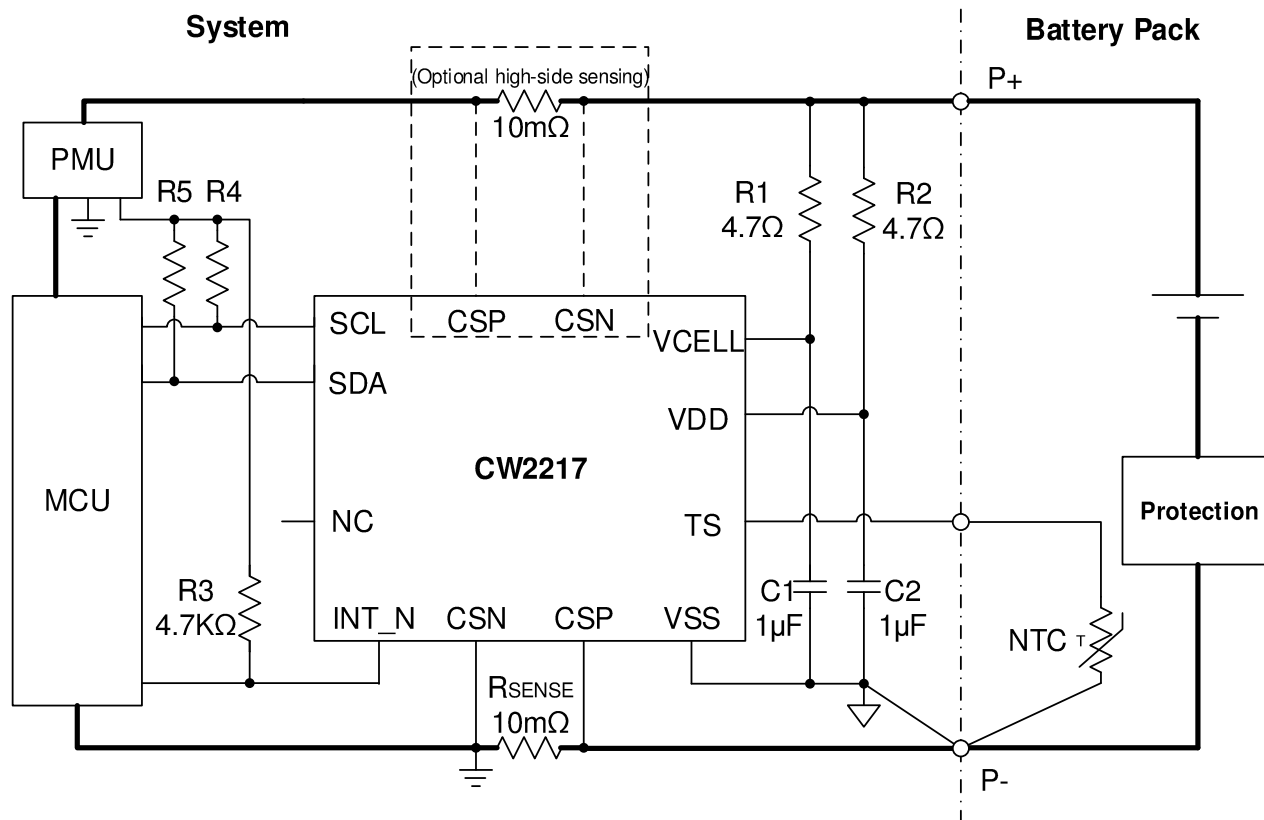

Figure 26. Typical Application for Single Cell

Power Supply Decoupling

The battery pack connection to the VCELL pin is used for voltage measurement of the cell and the connection to the VDD is to power the fuel gauge IC. Bypass capacitors whose effective value after considering the derating of capacitor should be at least 1μF should be added on VCELL and VDD pins. One 100ohm resistor is good to put in front of the VCELL and VDD pin respectively and the RC can filter the noise on the power supply net.

Sense Resistor

Any variation encountered in the resistance present between the CSP and CSN pins will affect the resulting differential voltage and the derived current it senses. Thus, it is recommended to select a sense resistor with minimal tolerance and temperature coefficient of resistance (TCR) characteristics. The recommendation is using ±1% tolerance, 50 ppm drift sense resistor. And the power rating of the sense resistor should be considered according to the application.

PCB Layout Guide

To ensure the measurement accuracy of the CW2217, the recommended layout guideline is as below:

- 1) Place the VCELL and VDD bypass capacitors as close to the IC as possible to avoid the noise effect.
- 2) The VCELL and VSS path should be Kelvin sense routing connected to the P+ and P- to minimize the IR drop effect on voltage measurement accuracy.
- 3) The CSP and CSN pins must be Kelvin sense routing connected to the sense resistor terminals.
- 4) The NTC thermistor should be as close as possible to the battery and far away from the thermal area.

Typical Applications (continued.) (Note1, 2, 3)

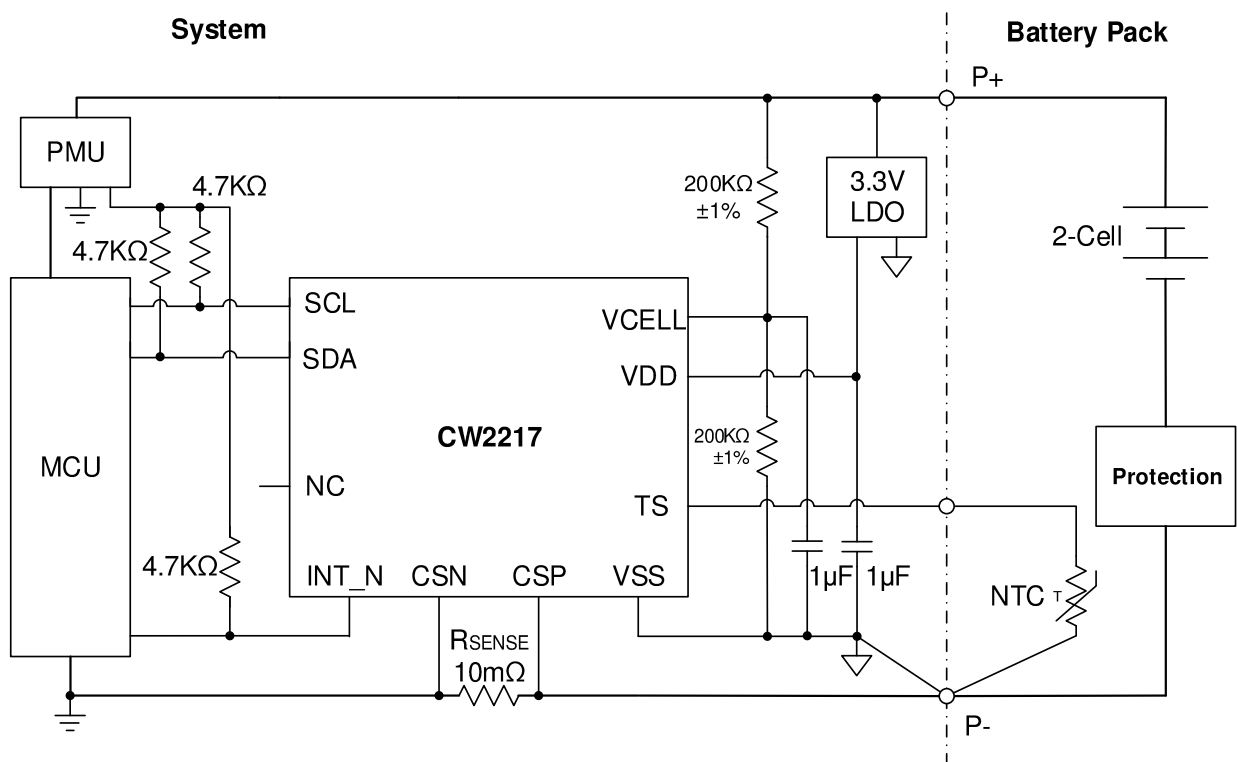

Figure 27. Typical Application for 2-Cell System Side

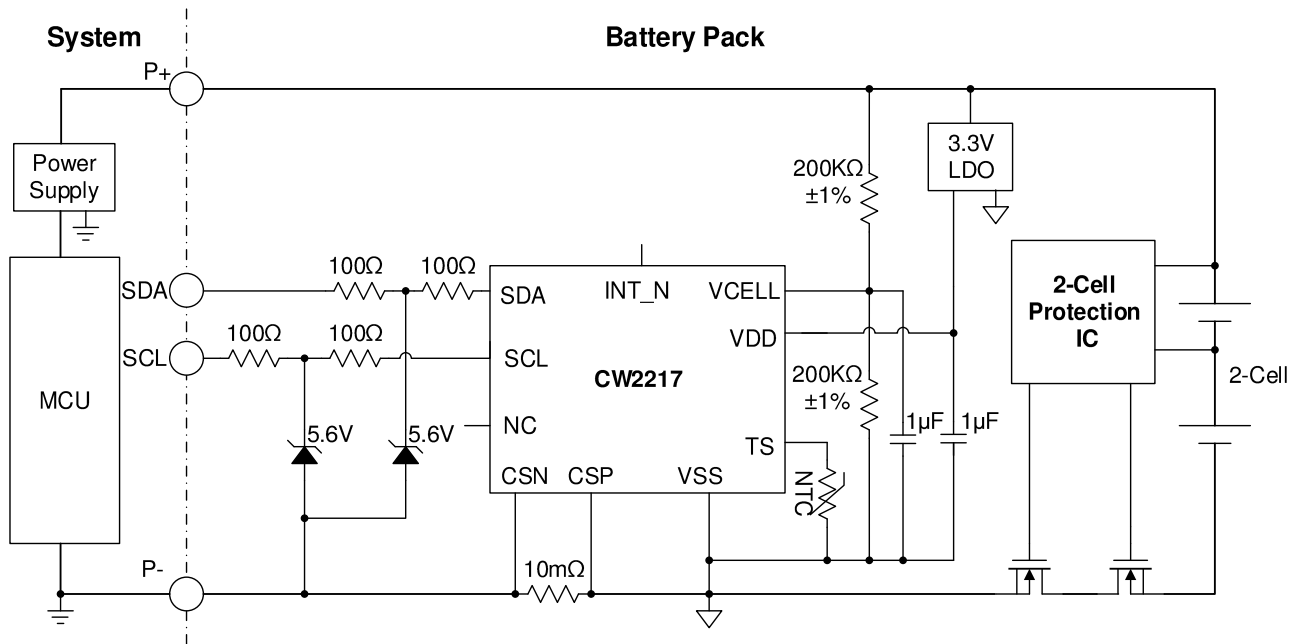

Figure 28. Typical Application for 2-Cell Pack Side

Note:

- 1) Add TVS diode at I²C interface when using in a removable battery pack.
- 2) For applications using multiple cells in serials, a voltage divider can be used to adapt the CW2217 usage, but it does not provide any individual cell information. Therefore, cell balance circuits are recommended to maintain the pack safety.
- 3) It is up to the pack maker and the original equipment manufacturer to make sure that the multiple cells in series are not out of balance and that the safety of the pack is maintained.

Package Information

DFN-12 Package

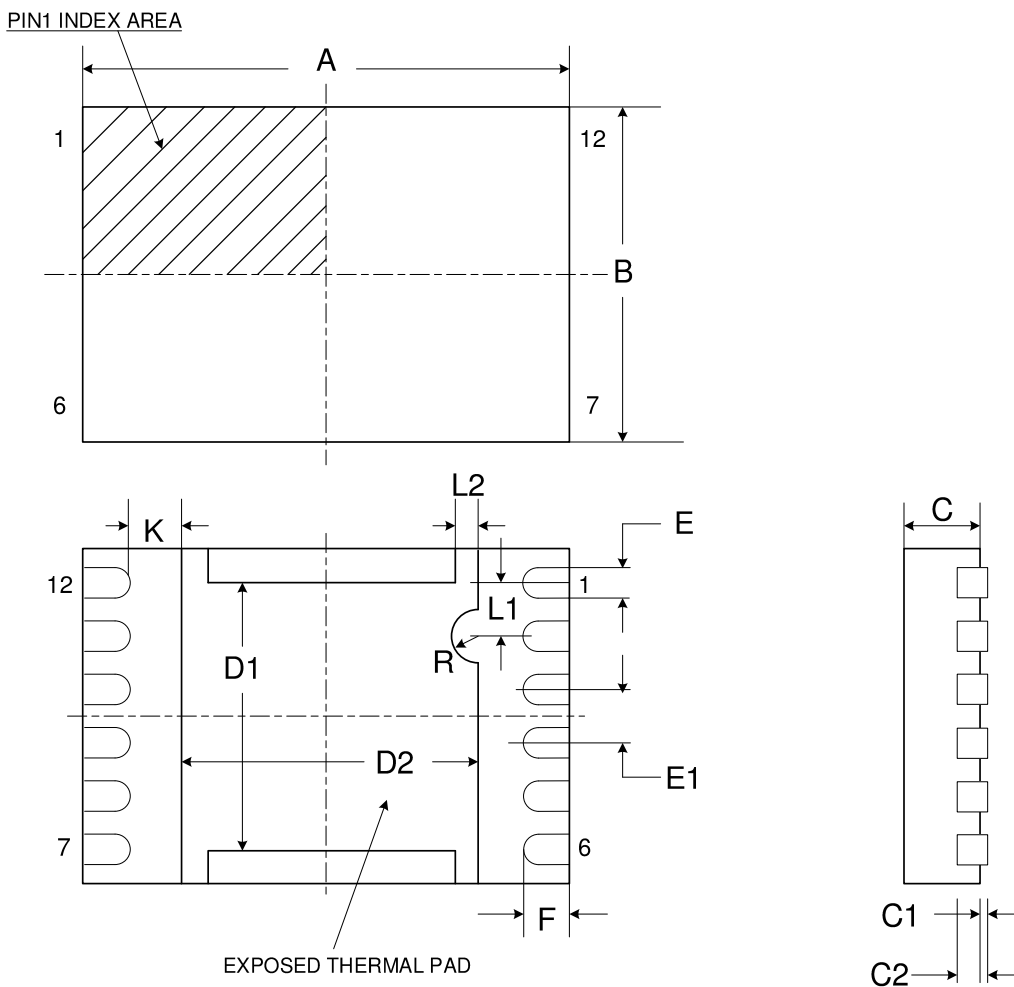

SYMBOL	UNIT (mm)		
	MIN	TYP	MAX
A	3.90	4.00	4.10
B	2.40	2.50	2.60
C	0.70	0.75	0.80
C1	0	0.02	0.05
C2	0.203 REF		
D1	2.00 BSC		
D2	2.50 BSC		
E	0.15	0.20	0.25
E1	0.40 BSC		
F	0.30	0.40	0.50
R	0.15	0.20	0.25
L1	0.40REF		
L2	0.14REF		
K	0.35REF		

Tape and Reel Information

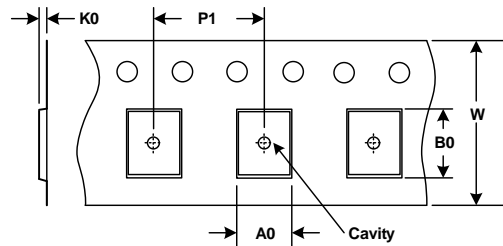
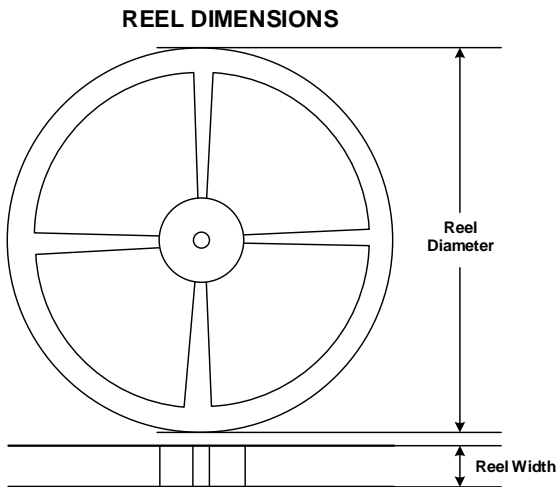

A0	Dimension designed to accommodate the component width
B0	Dimension designed to accommodate the component length
K0	Dimension designed to accommodate the component thickness
W	Overall width of the carrier tape
P1	Pitch between successive cavity centers

QUADRANT ASSIGNMENTS FOR PIN 1 ORIENTATION IN TAPE

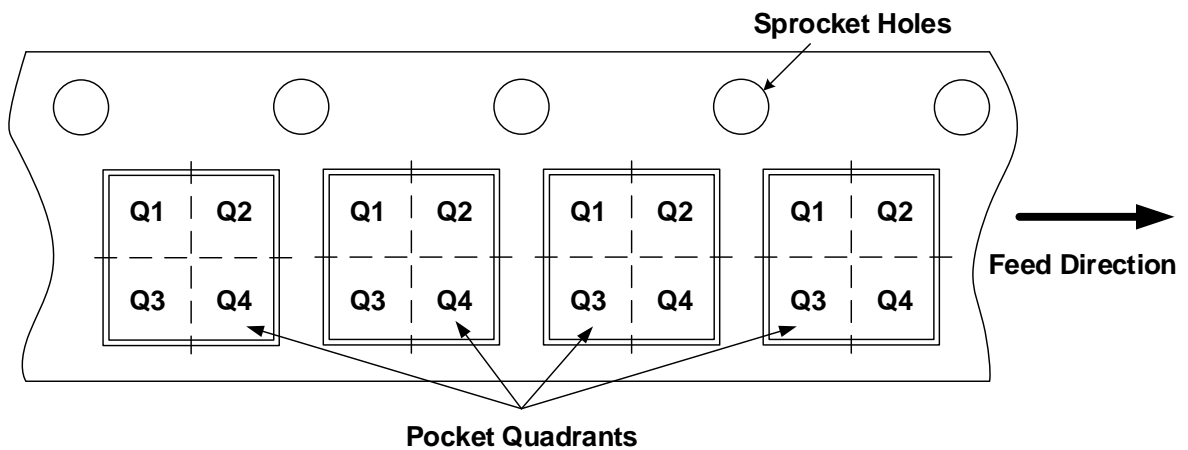

Device	Package Type	Reel Diameter (mm)	Reel Width (mm)	A0 (mm)	B0 (mm)	K0 (mm)	P1 (mm)	W (mm)	Pin 1 Quadrant
CW2217BAAD	DFN-12	330	12.4	2.7	4.2	1.1	8.0	12.0	Q2

Note: All dimensions are nominal.

Revision History

Release No.	Date	Revision Description
1.0	2022.03.06	Data Sheet Initial Release

DISCLAIMER

CELLWISE reserves the right to make changes without further notices to any products herein to improve reliability, function or design. CELLWISE does not assume any liability arising out of the application or use of any product or circuit described herein; neither does it convey any license under its patent rights, nor the rights of others.

CELLWISE's products are not authorized for use as critical components in life support devices or systems without the express written approval of the president of CELLWISE corporation.

As used herein:

- 1. Life support devices or systems are devices or systems which, (a) are intended for surgical implant into the body, or (b) support or sustain life, and (c) whose failure to perform when properly used in accordance with instructions for use provided in the labeling, can be reasonably expected to result in a significant injury of the user.*
- 2. A critical component in any component of a life support device or system whose failure to perform can be reasonably expected to cause the failure of the life support device or system, or to affect its safety or effectiveness.*