

General Features

- Low Gate Charge
- Advanced Trench Technology
- Provide Excellent RDS(ON)
- High Power and Current Handling Capability

Application

- Load Switch
- PWM applications
- Power management

Product Summary



VDS	30	V
RDS(on), Typ. @ VGS=10 V	3.0	mΩ
ID	90	A

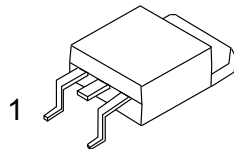

TO-252

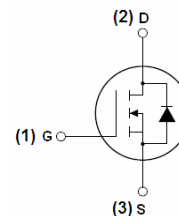

N-channel

Absolute Maximum Ratings (T_A =25°C unless otherwise noted)

Parameter	Symbol	Maximum	Units
Drain-Source Voltage	V _{DS}	30	V
Gate-Source Voltage	V _{GS}	±20	V
Continuous Drain Current ^B	I _D	T _C =25°C	90
		T _C =100°C	46
Pulsed Drain Current ^A	I _{DM}	255	A
Avalanche Current ^A	I _S	90	A
Single Pulse Avalanche Energy L =0.3mH ^A	E _{AS}	135	mJ
Power Dissipation ^C	P _D	T _C =25°C	65
		T _C =100°C	32
Junction and Storage Temperature Range	T _J , T _{STG}	-55 to 175	°C
Thermal Characteristics			
Parameter	Symbol	Maximum	Units
Maximum Junction-to-Case	R _{θJC}	2.3	°C/W
Maximum Junction-to-Ambient	R _{θJA}	100	

Electrical Characteristics($T_J = 25^\circ\text{C}$ unless otherwise noted)							
Symbol	Parameter	Conditions	Value			Units	
			Min	Typ	Max		
STATIC PARAMETERS							
BV_{DSS}	Drain-Source Breakdown Voltage	$I_D = 250\mu\text{A}, V_{GS} = 0\text{V}$	30	--	--	V	
I_{DSS}	Zero Gate Voltage Drain Current	$V_{DS} = 30\text{V}, V_{GS} = 0\text{V}$	$T_J = 25^\circ\text{C}$	--	--	1	μA
			$T_J = 125^\circ\text{C}$	--	--	25	
I_{GSS}	Gate-Body Leakage Current	$V_{DS} = 0\text{V}, V_{GS} = \pm 20\text{V}$	--	--	± 100	nA	
$V_{GS(th)}$	Gate Threshold Voltage	$V_{DS} = V_{GS}, I_D = 250\mu\text{A}$	1	1.7	2.4	V	
$R_{DS(on)}$	Static Drain-Source On-Resistance	$V_{GS} = 10\text{V}, I_D = 30\text{A}$	--	3.0	4.5	$\text{m}\Omega$	
		$V_{GS} = 4.5\text{V}, I_D = 30\text{A}$	--	4.8	6.5	$\text{m}\Omega$	
g_{FS}	Forward Transconductance	$V_{DS} = 10\text{V}, I_D = 20\text{A}$	16	--	--	S	
V_{SD}	Diode Forward Voltage	$I_S = 30\text{A}, V_{GS} = 0\text{V}$	--	--	1	V	
I_S	Maximum Body-Diode Continuous Current ^B		--	--	90	A	
DYNAMIC PARAMETERS							
C_{iss}	Input Capacitance	$V_{GS} = 0\text{V}, V_{DS} = 15\text{V}, f = 1\text{MHz}$	--	2120	--	pF	
C_{oss}	Output Capacitance		--	307	--		
C_{rss}	Reverse Transfer Capacitance		--	253	--		
SWITCHING PARAMETERS							
Q_g	Total Gate Charge	$V_{GS} = 10\text{V}, V_{DS} = 15\text{V}, I_D = 30\text{A}$	--	40	--	nC	
Q_{gs}	Gate Source Charge		--	5.4	--		
Q_{gd}	Gate Drain Charge		--	9.6	--		
$t_{D(on)}$	Turn-On Delay Time	$V_{GS} = 10\text{V}, V_{DS} = 15\text{V}, I_D = 20\text{A}, R_G = 3\Omega$	--	15	--	ns	
t_r	Turn-On Rise Time		--	32	--		
$t_{D(off)}$	Turn-Off Delay Time		--	15	--		
t_f	Turn-Off Fall Time		--	12	--		
t_{rr}	Body Diode Reverse Recovery Time	$I_F = 30\text{A}, di/dt = 100\text{A}/\mu\text{s}$	--	23	--	ns	
Q_{rr}	Body Diode Reverse Recovery Charge		--	48	--	nC	

A. Single pulse width limited by maximum junction temperature.

B. The maximum current rating is package limited.

C. The power dissipation P_D is based on $T_{J(MAX)} = 175^\circ\text{C}$, using junction-to-case thermal resistance, and is more useful in setting the upper dissipation limit for cases where additional heatsinking is used.

Typical Characteristics $T_J = 25^\circ\text{C}$, unless otherwise noted

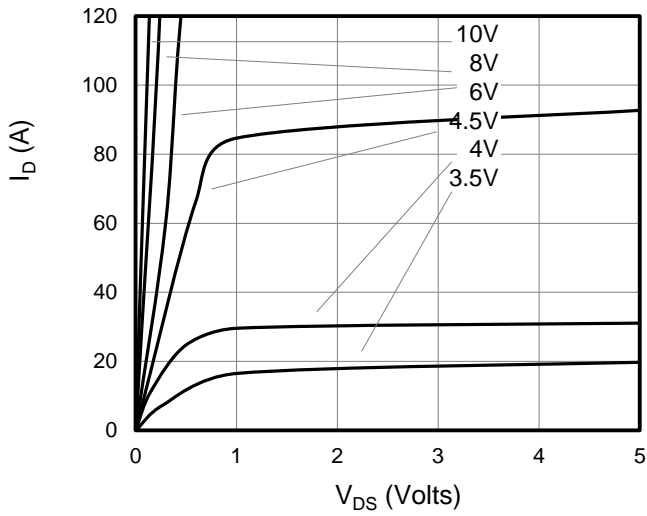

Figure 1: On-Region Characteristics

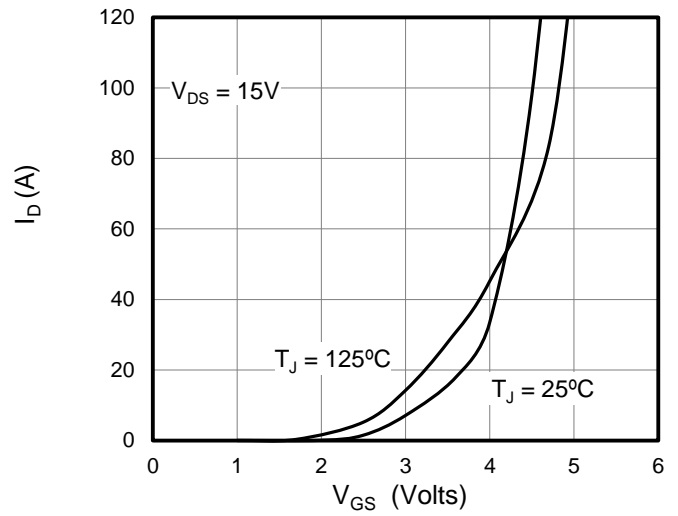

Figure 2: Transfer Characteristics

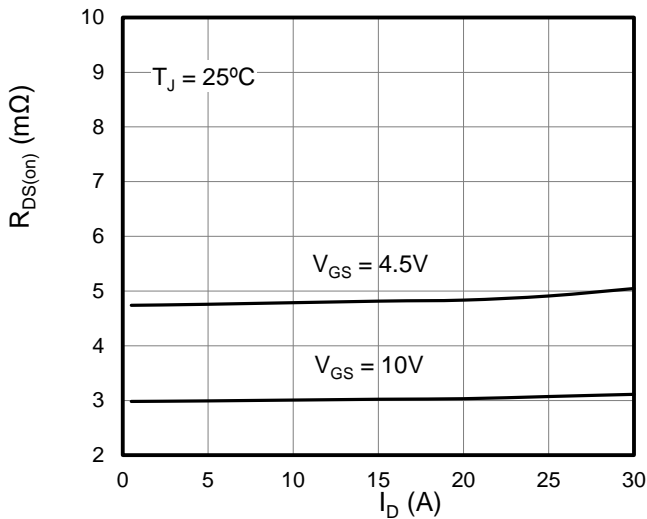

Figure 3: On-Resistance vs. Drain Current

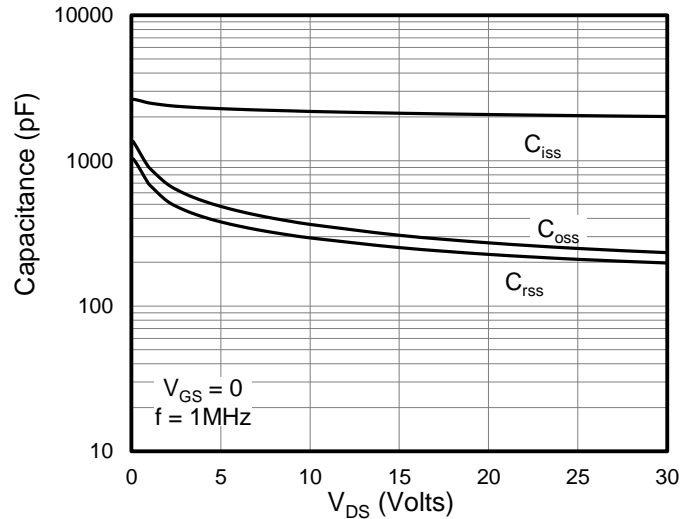

Figure 4: Capacitance Characteristics

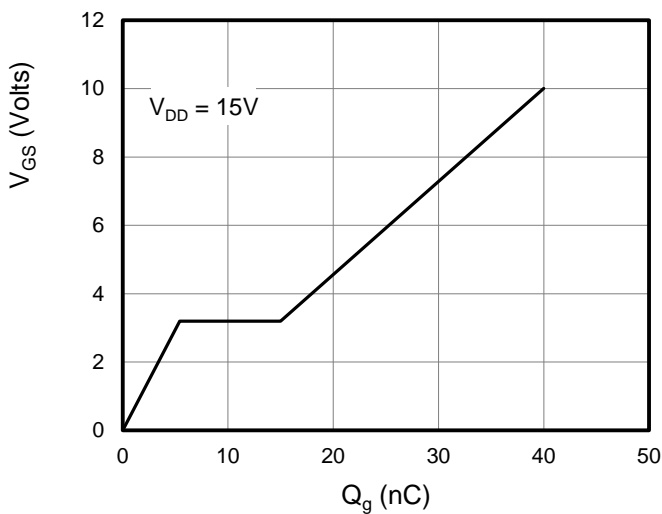

Figure 5: Gate Charge Characteristics

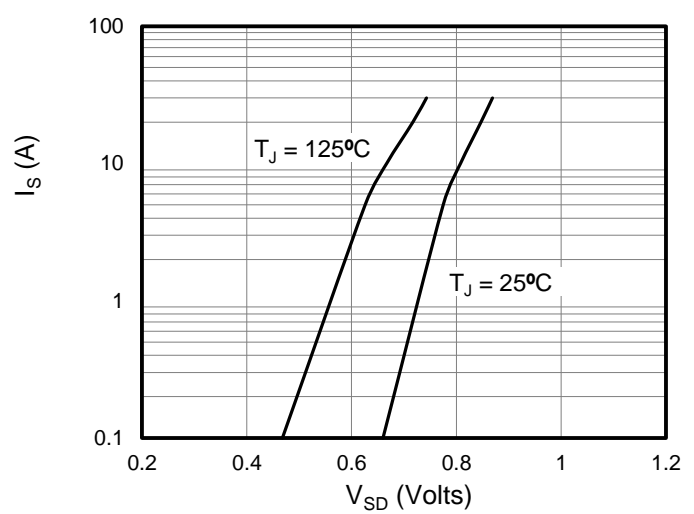

Figure 6: Body Diode Forward Voltage

Typical Characteristics $T_J = 25^\circ\text{C}$, unless otherwise noted

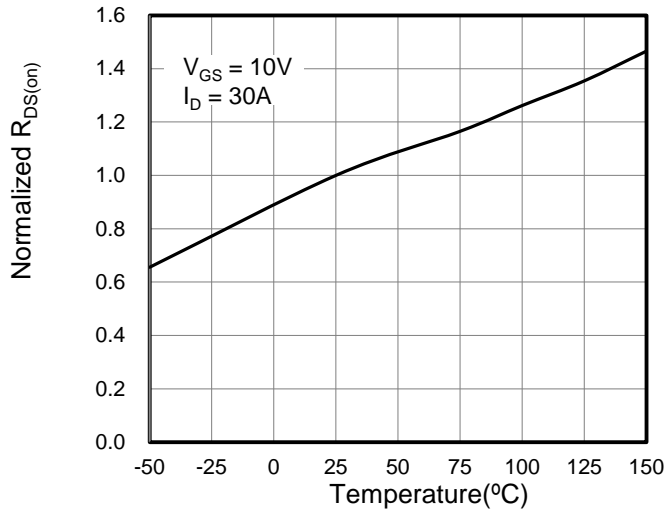

Figure 7: On-Resistance vs. Junction Temperature

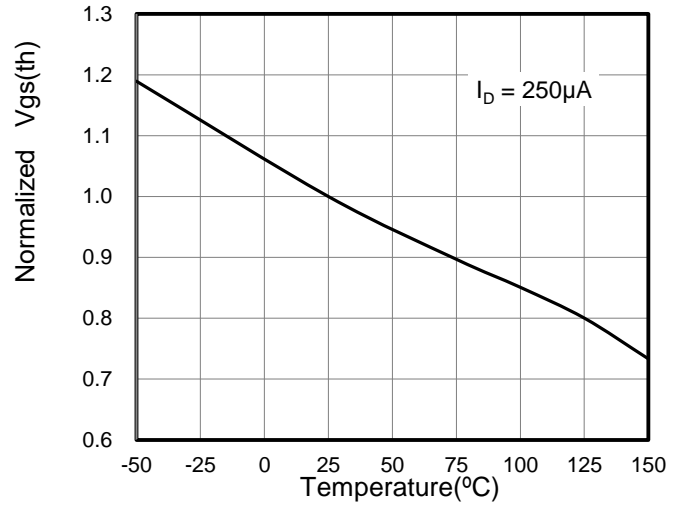

Figure 8: $V_{GS(th)}$ vs. Junction Temperature

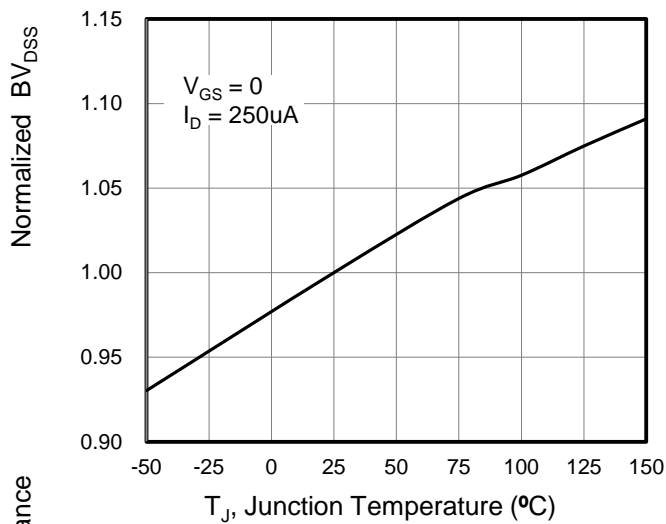

Figure 9: BV_{DS} vs. Junction Temperature

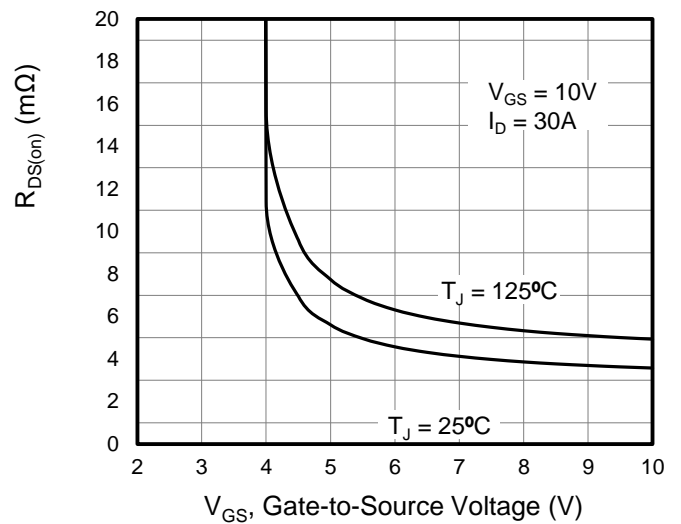

Figure 10: On-Resistance vs. Gate-Source Voltage

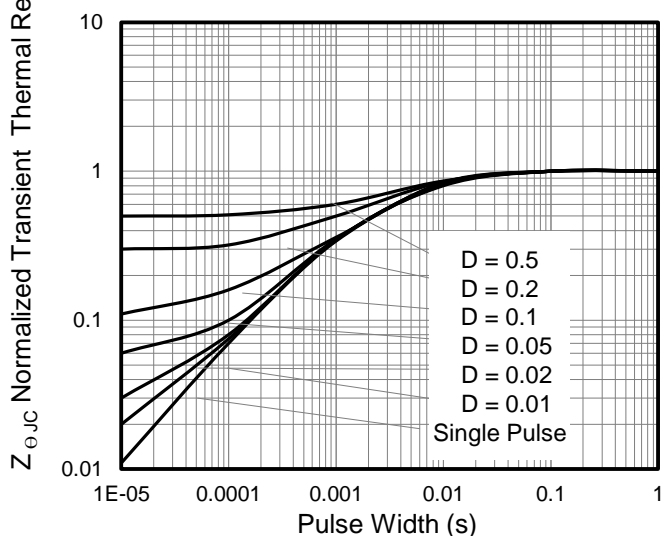

Figure 11: Normalized Transient Thermal Resistance

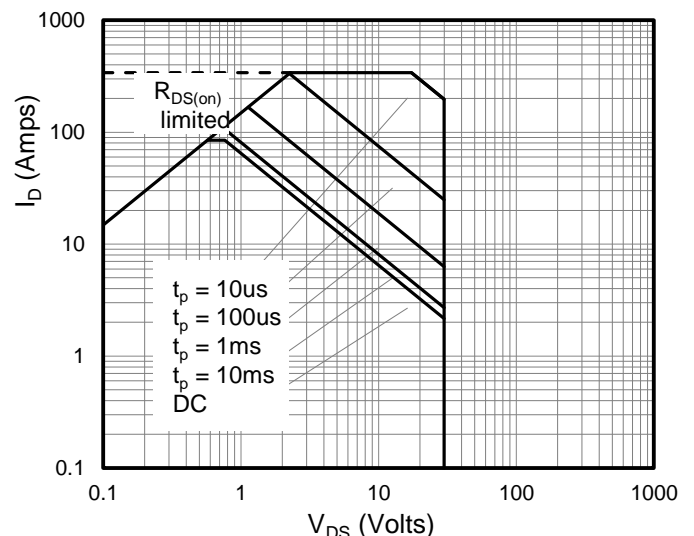
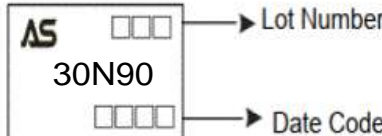
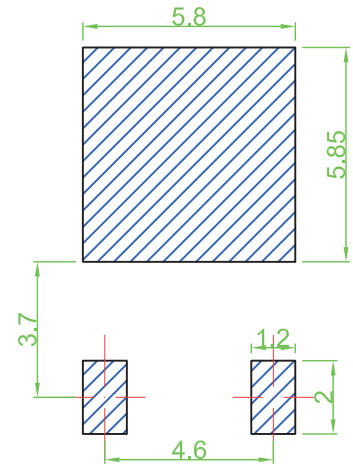
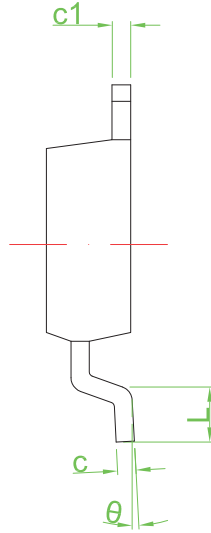
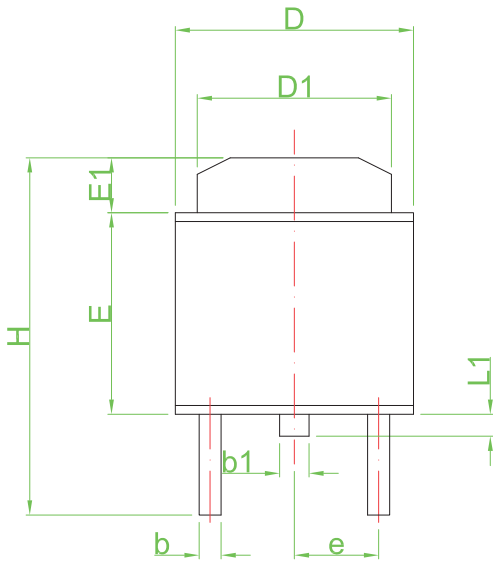
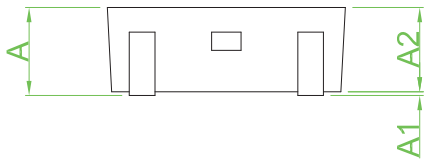

Figure 12: Safe Operating Area

Ordering and Marking Information

Ordering Device No.	Marking	Package	Packing	Quantity
ASDM30N90KQ-R	30N90	TO-252	Tape&Reel	2500/Reel

PACKAGE	MARKING
TO-252	 <p>AS □□</p> <p>30N90</p> <p> □□□□</p> <p> → Lot Number</p> <p> → Date Code</p>

TO-252 PACKAGE IN FORMATION

Recommended Land Pattern

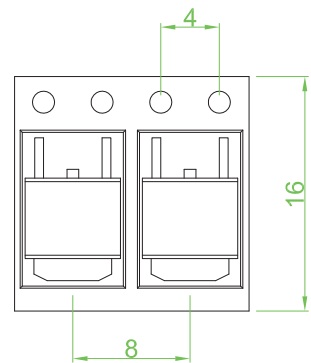
Symbol	Dimensions in Millimeters		Dimensions in Inches	
	Min	Max	Min	Max
A	2.25	2.65	0.089	0.104
A1	0.00	0.15	0.000	0.006
A2	2.20	2.40	0.087	0.094
b	0.50	0.70	0.020	0.028
b1	0.70	0.90	0.028	0.035
c	0.46	0.66	0.018	0.026
c1	0.46	0.66	0.018	0.026
D	6.30	6.70	0.248	0.264
D1	5.20	5.40	0.205	0.213
E	5.30	5.70	0.209	0.224
E1	1.40	1.60	0.055	0.063
H	9.40	9.90	0.370	0.390
e	2.30 TYP		0.09 TYP	
L	1.40	1.77	0.055	0.070
L1	0.50	0.70	0.020	0.028
θ	0°	8°	0°	8°



IMPORTANT NOTICE

ShenZhen Ascend Semiconductor incorporated MAKES NO WARRANTY OF ANY KIND, EXPRESS OR IMPLIED, WITH REGARDS TO THIS DOCUMENT, INCLUDING, BUT NOT LIMITED TO, THE IMPLIED WARRANTIES OF MERCHANTABILITY AND FITNESS FOR A PARTICULAR PURPOSE (AND THEIR EQUIVALENTS UNDER THE LAWS OF ANY JURISDICTION).

ShenZhen Ascend Semiconductor Incorporated and its subsidiaries reserve the right to make modifications, enhancements, improvements, corrections or other changes without further notice to this document and any product described herein. ShenZhen Ascend Semiconductor Incorporated does not assume any liability arising out of the application or use of this document or any product described herein; neither does ShenZhen Ascend Semiconductor Incorporated convey any license under its patent or trademark rights, nor the rights of others. Any Customer or user of this document or products described herein in such applications shall assume .

all risks of such use and will agree to hold Ascendsemi Incorporated and all the companies whose products are represented on ShenZhen Ascend Semiconductor Incorporated website, harmless against all damages.

ShenZhen Ascend Semiconductor Incorporated does not warrant or accept any liability whatsoever in respect of any products purchased through unauthorized sales channel. Should Customers purchase or use ShenZhen Ascend Semiconductor Incorporated products for any unintended or unauthorized application, Customers shall indemnify and hold ShenZhen Ascend Semiconductor Incorporated and its representatives harmless against all claims, damages, expenses, and attorney fees arising out of, directly or indirectly, any claim of personal injury or death associated with such unintended or unauthorized application.

www.ascendsemi.com