

注: 未经允许禁止传输、复制、编辑该文档, 以及利用其内容进行交流

REV	E.C.N NO.	CONTENT	CHK	DATE

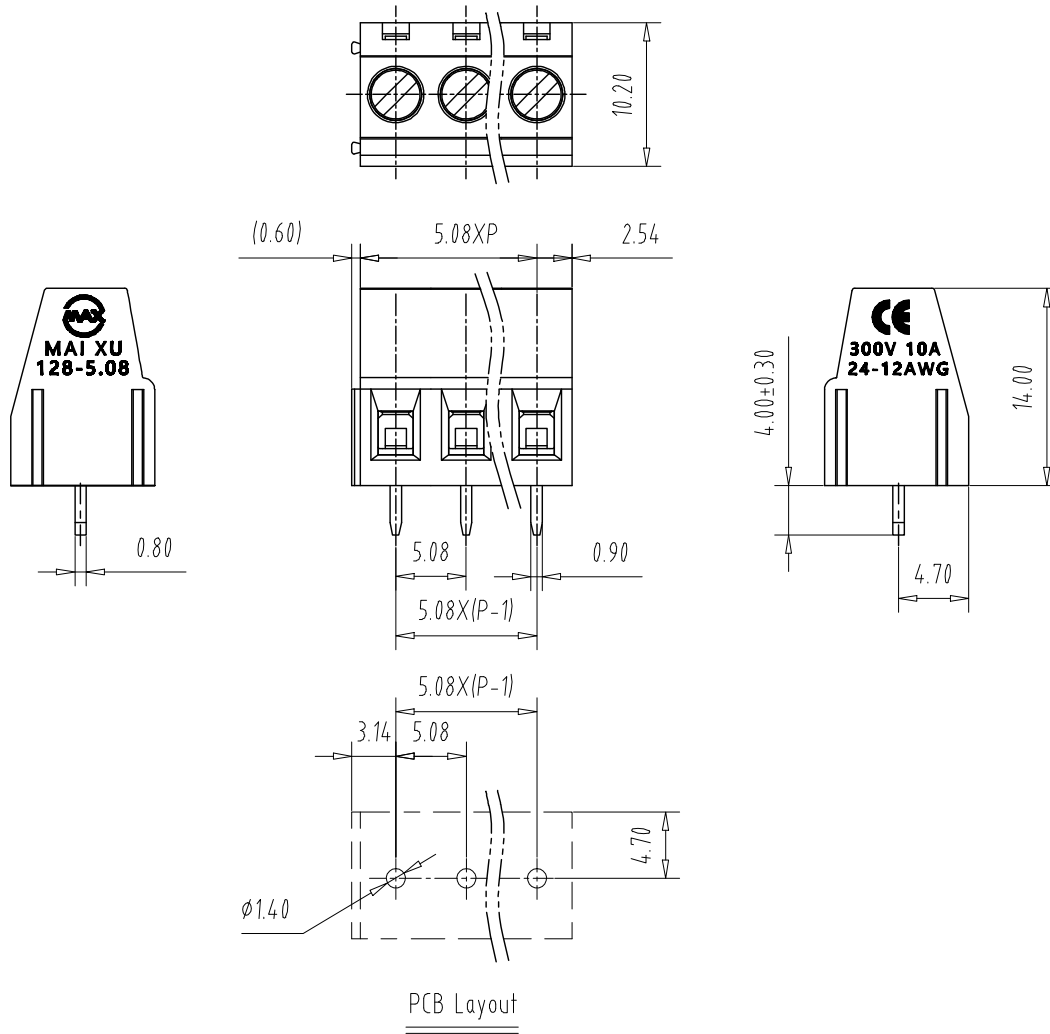

NOTES1:

UL Standard

- 1.Rating voltage/current: 300V/10A
- 2.withstanding voltage: AC2000V/1Min
- 3.Torque value: M2.5, 3.54Lb.in
- 4.Wire range: 24~12AWG

IEC Standard

1. Pollution Degree	3	2	2
Overvoltage Category	III	III	II
Rate Impulse Voltage(KV)	4	4	4
Rate Voltage(V)	250V	400V	630V
Rate Current(A)	18A	18A	18A

2. Torque value: M2.5, 0.4Nm
- 3.wire range: 0.2-2.5mm²

NOTES2:

- 1.Housing: PA66(UL94V-0)
- 2.Solder Pin: Brass(Sn Plated)
- 3.Cage: Brass(Ni Plated)
- 4.Screw: Steel(M2.5,Zn Plated)

NOTES3:

- 1.Pitch: 5.08mm Poles: 02-24P
- 2.Stripping length: 6-7mm
- 3.Operating temperature: -40℃~+105℃
- 4.RoHS Compliance

How to order

MX128 - 5.08 - XXP
 Factory Code poles

Pitch Range In mm			Nominal Dimension Range In mm					—	∩	□
TO 6	Over 6 TO 10	Over 10 TO 24	TO 30	Over 30 TO 60	Over 60 TO 100	Over 100 TO 150	Over 150	0.1/10		
±0.15	±0.20	±0.30	±0.30	±0.50	±0.70	±1.00	±1.30	<	±2°	

ITEM	NAME OF PART	NO. OF PART	Q'TY	MATERIAL	NOTE
DWG.	CKK	DATE	22.09.14	UNITS	MM
CHK.		DATE		SCALE	1:1
APP.		DATE			A4
				NAME	MX128-5.08-XXP
				DWGNO.	

CIXI MAIXU ELECTRONICS CO.,LTD.
 慈溪迈旭电子有限公司