



SPECIFICATION FOR APPROVAL

承 认 书

客户名称 (CUSTOMER) 华秋

品名规格 (ITEM SPECS) EI41-345

客户料号 (CUS.PART.NO) DL701-34P (100V-25V)

众凯料号 (ZK SKU.NO) ZKH1531EI41-16207

日期 (DATE) 2023/7/4

APPROVED BY	CHECKED BY	INSPECTED BY

如蒙承认，请予签回

东 莞 市 众 凯 电 子 有 限 公 司

DONGGUAN ZHONGKAI ELECTRONICS CO., LTD

TEL:0769-87725171/87927716/87927715

FAX:0769-87884663

[Http://www.dgzhk.com](http://www.dgzhk.com)

E-mail:webmaster@dgzhk.com

地址:广东省东莞市塘厦镇田心莆龙工业区莆田2路3号A栋

Add: No. 3A, Putian Second Road, Pulong industry area, Tianxin, Tangxia
Town, Dongguan City, Guangdong Province, China



客户名称 CUSTOMER	华秋	客户料号 CUS. PART. NO	DL701-34P(100V-25V)	版次 REV: A
品名规格 ITEM SPECS	EI41-345	众凯料号 ZK SKU. NO	ZKH1531EI41-16207	数量 Q' TY: 2PCS
				R. H. 65% TEMP: 25°C

1. 外观尺寸 DIMENSIONS (UNIT: mm)

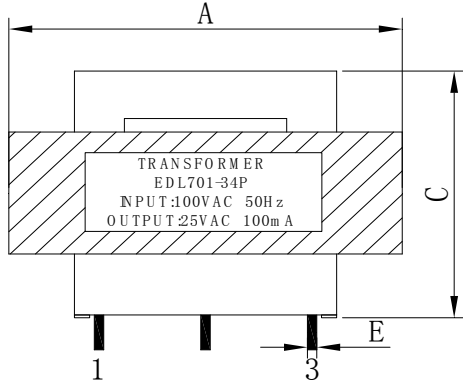

正视图
FRONT VIEW

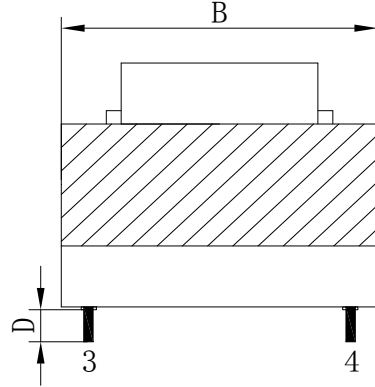

侧视图
SIDE VIEW

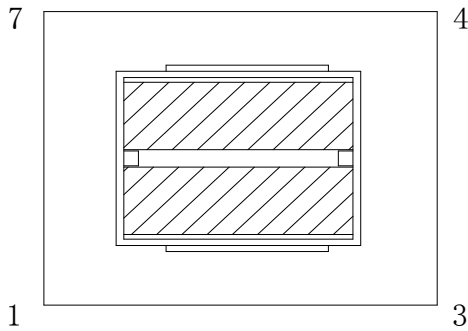

顶视图
TOP VIEW

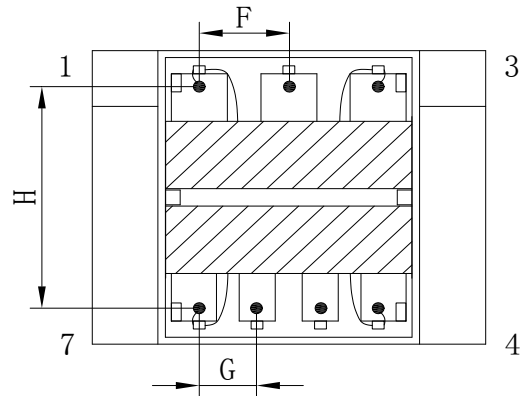

底视图
BOTTOM VIEW

A	43.0MAX	E	1.0±0.1	I		N			
B	35.0MAX	F	10.35±0.5	J		O			
C	29.0MAX	G	7.0±0.5	K		P			
D	4.0±0.5	H	24±0.5	M		Q			

拟定 (DRAFT BY)	制作 (MADE BY)	审核 (CHECKED BY)	核准 (APPROVED BY)
严小桂2023/7/4			



众凯电子有限公司

ZHONGKAI ELECTRONICS CO., LTD
SPECIFICATION FOR APPROVAL

页码:

客户名称 CUSTOMER	华秋	客户料号 CUS. PART. NO.	DL701-34P(100V-25V)	版次 REV: A
品名规格 ITEM SPECS	EI41-345	众凯料号 ZK SKU. NO.	ZKH1531EI41-16207	数量 Q' TY:2PCS
				R. H. 65% TEMP:25°C

2. 原理图(Schematic Diagram)

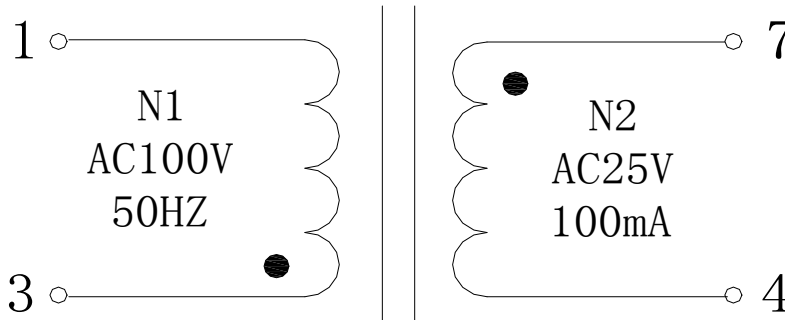

3. 绕线层次图 (Winding Layer Diagram)

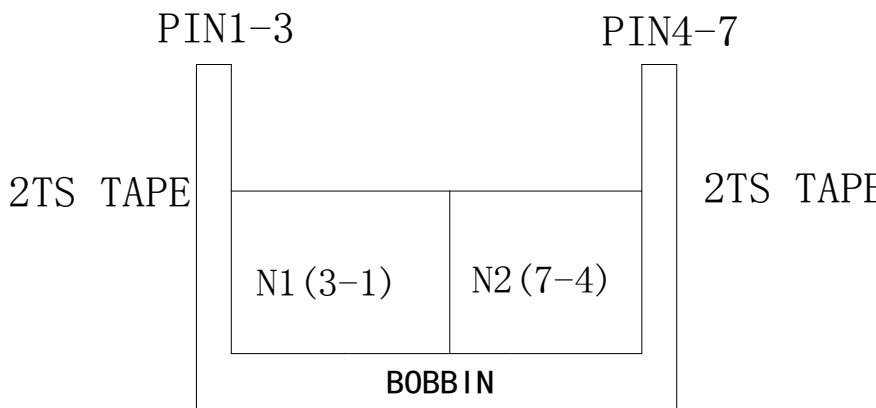

4. 绕线结构表(Winding Structure Diagram)

绕组	S-F		WIRE	TURNS	WINDING MOTHEd	TAPE TURNS	套管		挡墙		
	S	F					S	F	PIN1-3	PIN4-7	
N1											
N2											
CORE FIX TAPE				15.0W*0.025t*3TS							
拟定 (DRAFT BY)		制作 (MADE BY)			审核 (CHECKED BY)			核准 (APPROVED BY)			
严小桂2023/7/4											



众凯电子有限公司

ZHONG KAI ELECTRONICS CO., LTD

SPECIFICATION FOR APPROVAL

页码: 4/6

客户名称 CUSTOMER	华秋	客户料号 CUS. PART. NO.	DL701-34P(100V-25V)	版次 REV: A
品名规格 ITEM SPECS	EI41-345	众凯料号 ZK SKU. NO.	ZKH1531EI41-16207	数量 Q' TY: 2PCS
				R. H. 65% TEMP: 25°C

5. 注意说明 (Remark)

- PIN1-3脚朝外顺绕。
- 产品需真空含浸。
- PIN1-3脚侧需标识。

6. 电气特性 (Electrical Characteristics)

序号 Ref. No	测试项目 Test Item	测试脚位 Test Pin	规格要求 SPEC. Request	测试条件 Test Condition
①	初级	输入电压	AC100V/50HZ	
		空载电流	≤20mA	
②	次级	空载电压	AC30V±5%	
		负载	电压: AC25V±5% 电流: 100mA±5%	
③	耐压 (HI-POT)	P-S	AC2.5KV/5mA/60S	CS2672D
		P, S-CORE	AC2.5KV/5mA/60S	
④	绝缘阻抗		≥100MΩ DC500V/min	19053

拟定 (DRAFT BY)	制作 (MADE BY)	审核 (CHECKED BY)	核准 (APPROVED BY)
严小桂2023/7/4			



众凯电子有限公司

ZHONG KAI ELECTRONICS CO., LTD

SPECIFICATION FOR APPROVAL

页码: 5/6

客户名称 CUSTOMER	华秋	客户料号 CUS. PART. NO.	DL701-34P(100V-25V)	版次 REV: A
品名规格 ITEM SPEC.	EI41-345	众凯料号 ZK SKU. NO.	ZKH1531EI41-16207	数量 Q'TY: 2PCS
				R. H. 65% TEMP: 25°C

7. 物料清单 (Material List)

序号 Ref. No.	物料名称 Name	规格描述 Spec.	等级 Class	厂商 Supplier	UL. NO
①	BOBBIN	FR-530	94V-0	E I DUPONT DE NEMOURS & CO INC (OR Equal)	E41938
②	CORE	EI-41*H50	/	DONGGUAN ZHI LI ELECTRONICS CO., LTD	/
③	WIRE	TYA1-U155	155°C	HENG YA ELECTRIC (DONGGUAN) LTD (OR Equal)	E197768
		UEF1/U		PACIFIC ELECTRIC WIRE & CABLE (SHENZHEN) CO., LTD (OR Equal)	E201757
④	TAPE	CT*(c) (g)	130°C	JING JIANG YAHUA PRESSURE SENSITIVE GLUE CO., LTD (OR Equal)	E165111
⑤	SOLDER	Sn99.3Cu0.7	/	GUANGZHOU RESEARCH INSTITUTE OF NON- FERROUS METALS CO., LTD	/
⑥	VARNISH	T-4260 (a)	130°C	SUZHOU TAIHU INSULATING MATERIAL CO., LTD (OR Equal)	E228349
⑦					
⑧					

拟定 (DRAFT BY)	制作 (MADE BY)	审核 (CHECKED BY)	核准 (APPROVED BY)
严小桂2023/7/4			